



(19) **United States**

(12) **Patent Application Publication**
ABEDI et al.

(10) **Pub. No.: US 2023/0037925 A1**

(43) **Pub. Date: Feb. 9, 2023**

(54) **ROAD-SIDE DETECTION AND ALERT SYSTEM AND METHOD**

(52) **U.S. Cl.**
CPC **G08G 1/0955** (2013.01); **G08G 1/04** (2013.01); **G08G 1/166** (2013.01)

(71) Applicant: **The Auto Club Group**, Dearborn, MI (US)

(72) Inventors: **Shohreh ABEDI**, Bloomfield Hills, MI (US); **Luis CASTRO**, Riverview, FL (US); **Jeffrey LASKOWSKI**, Troy, MI (US); **Viral PATEL**, Canton, MI (US)

(57) **ABSTRACT**

An alert system and method comprising at least one alert beacon having one or more sensors (e.g., LiDAR sensor). The alert beacon further including a processor operable to poll the LiDAR sensor for a predefined number of beta readings in response to receiving an initial reading from the LiDAR sensor indicating a vehicle is within a predefined distance away from the alert beacon. The processor further being operable to calculate an average distance and an average velocity for the vehicle in response to receiving the predefined number of beta readings when the vehicle is within the predefined distance from the alert beacon. The processor also being operable to activate an audible alert and a visual alert when the average distance is below a distance threshold and the average velocity exceeds a velocity threshold in response to calculating the average distance and the average velocity.

(21) Appl. No.: **17/966,459**

(22) Filed: **Oct. 14, 2022**

Related U.S. Application Data

(63) Continuation of application No. 16/878,272, filed on May 19, 2020, now Pat. No. 11,508,239.

Publication Classification

(51) **Int. Cl.**
G08G 1/0955 (2006.01)
G08G 1/04 (2006.01)
G08G 1/16 (2006.01)

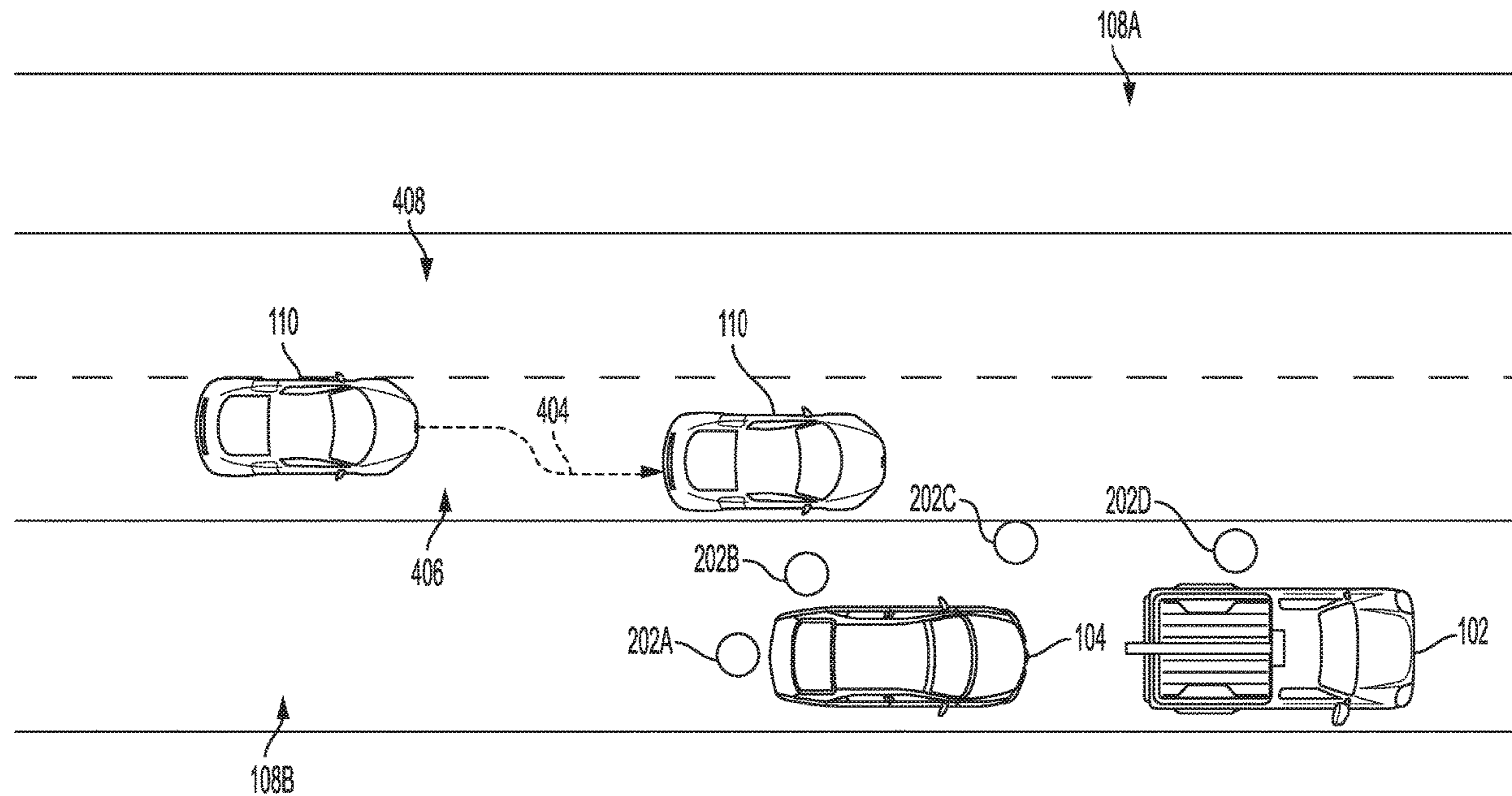

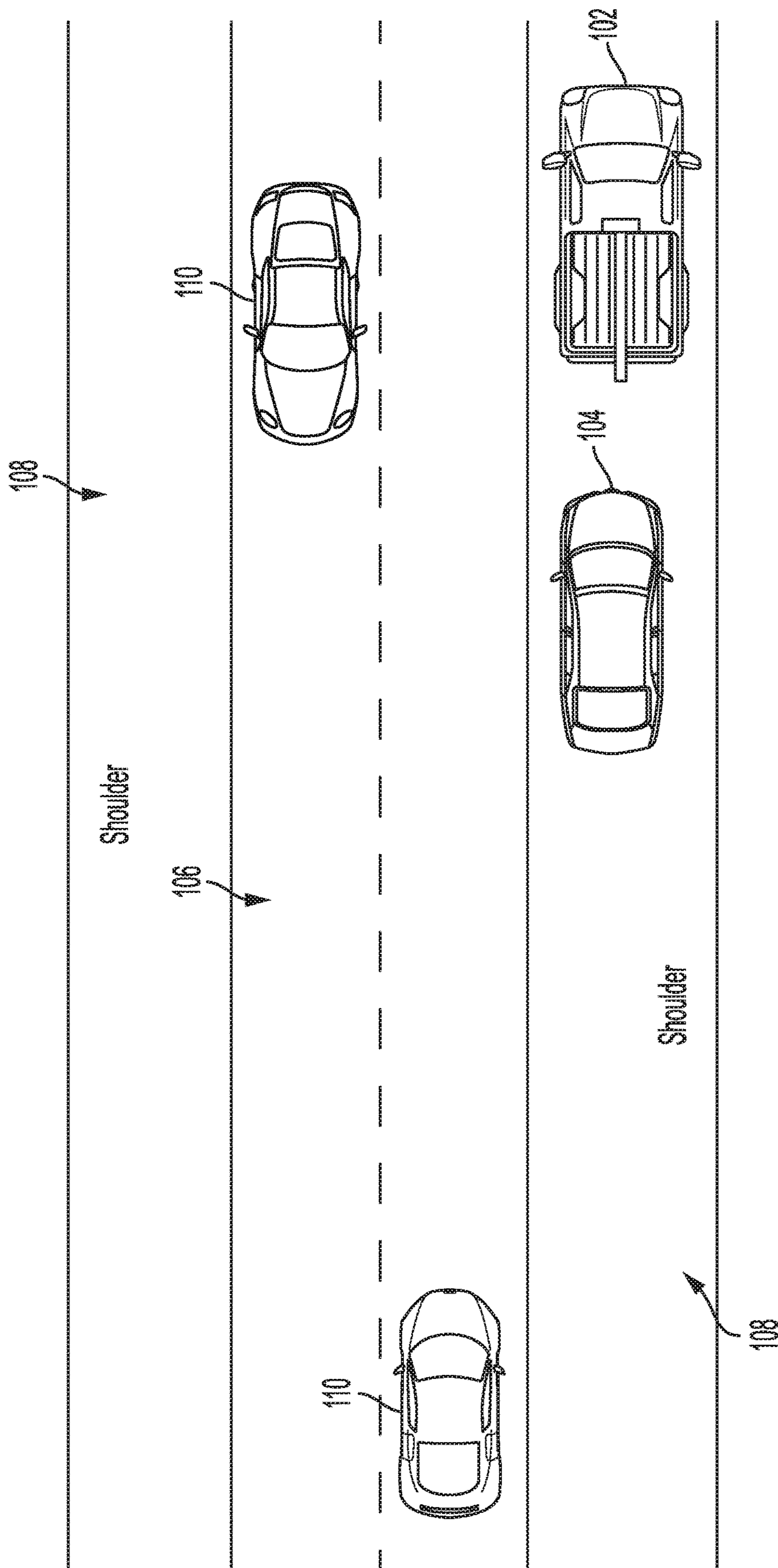

FIG. 1

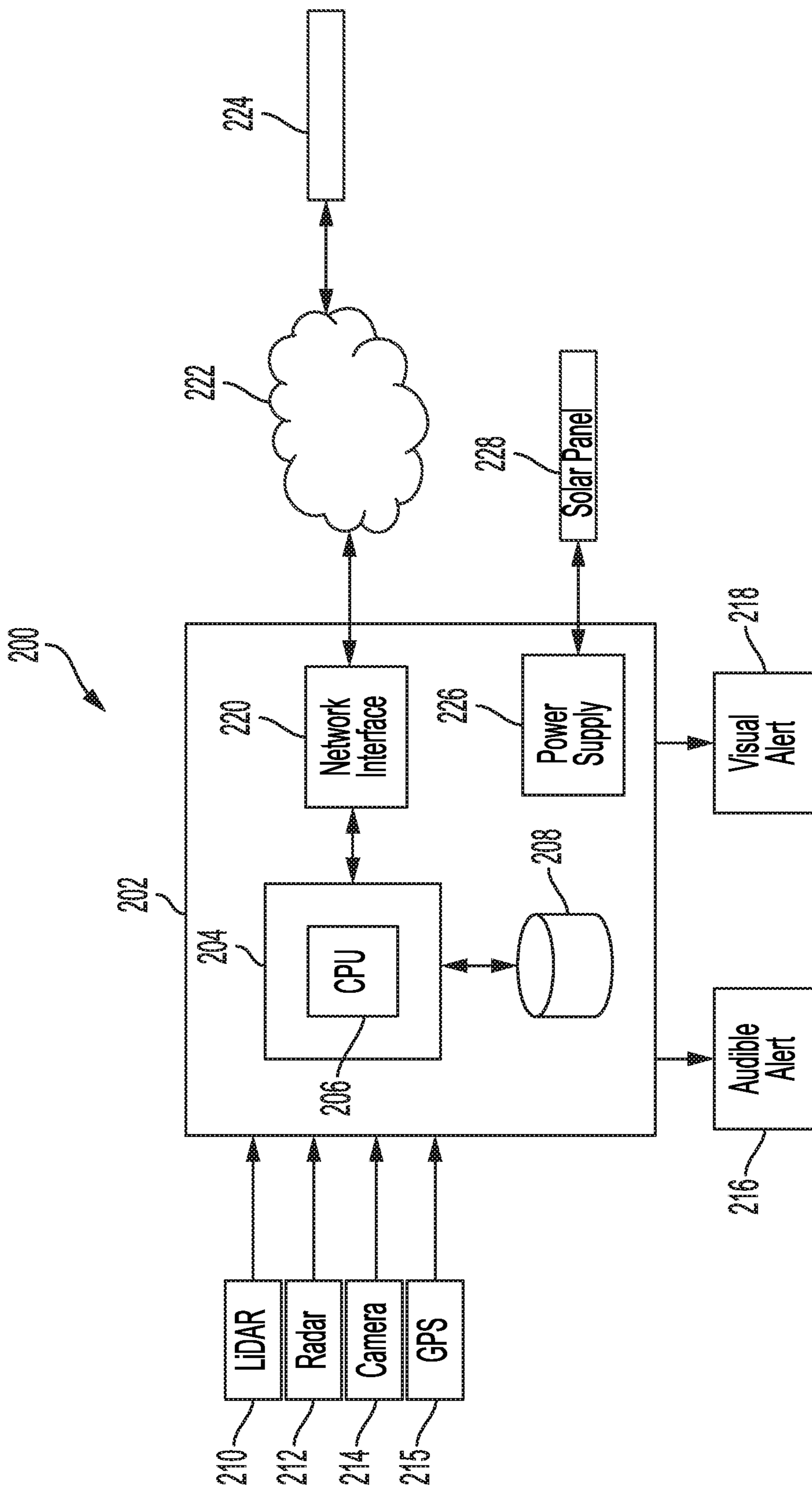

FIG. 2

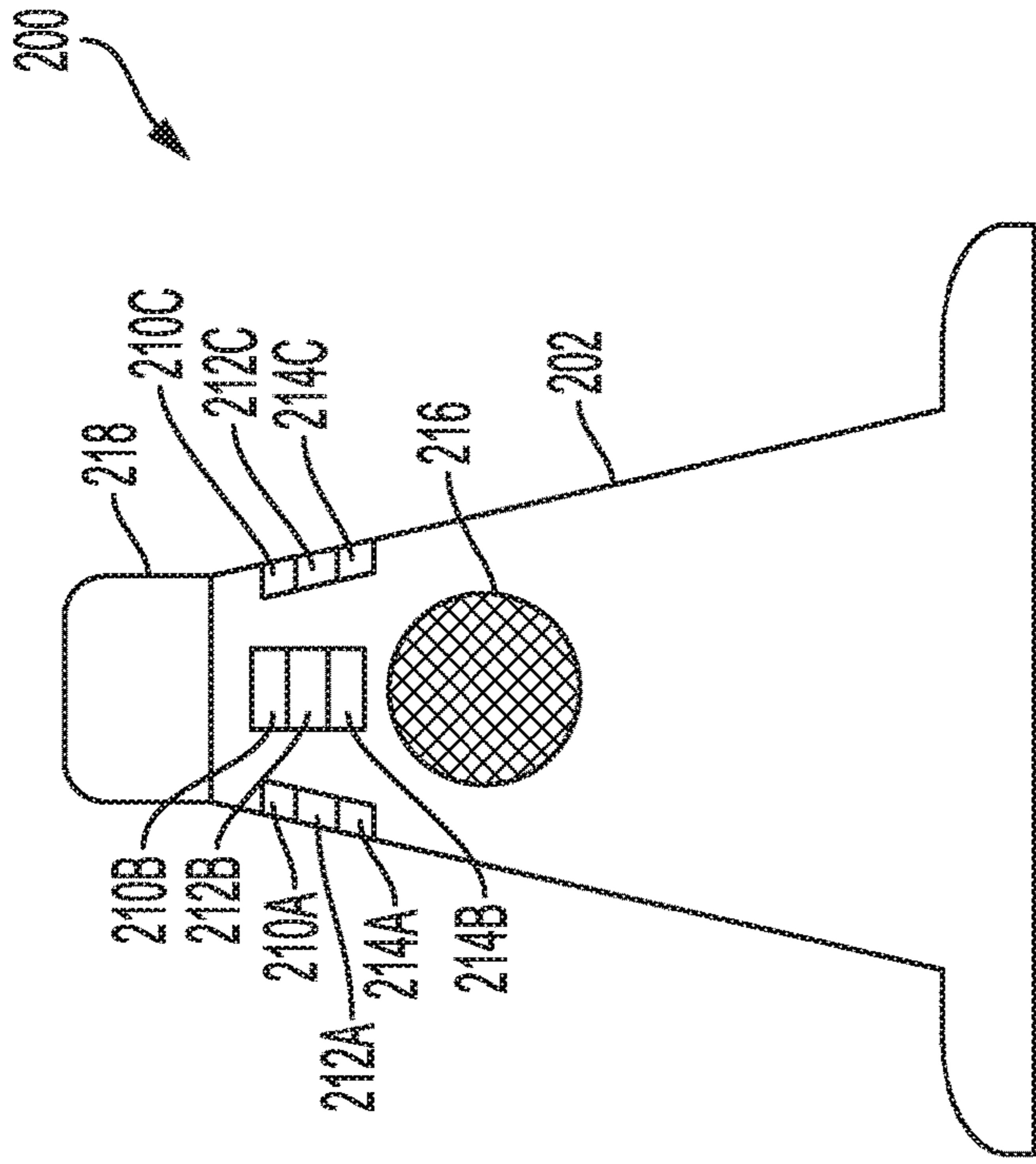

FIG. 3A

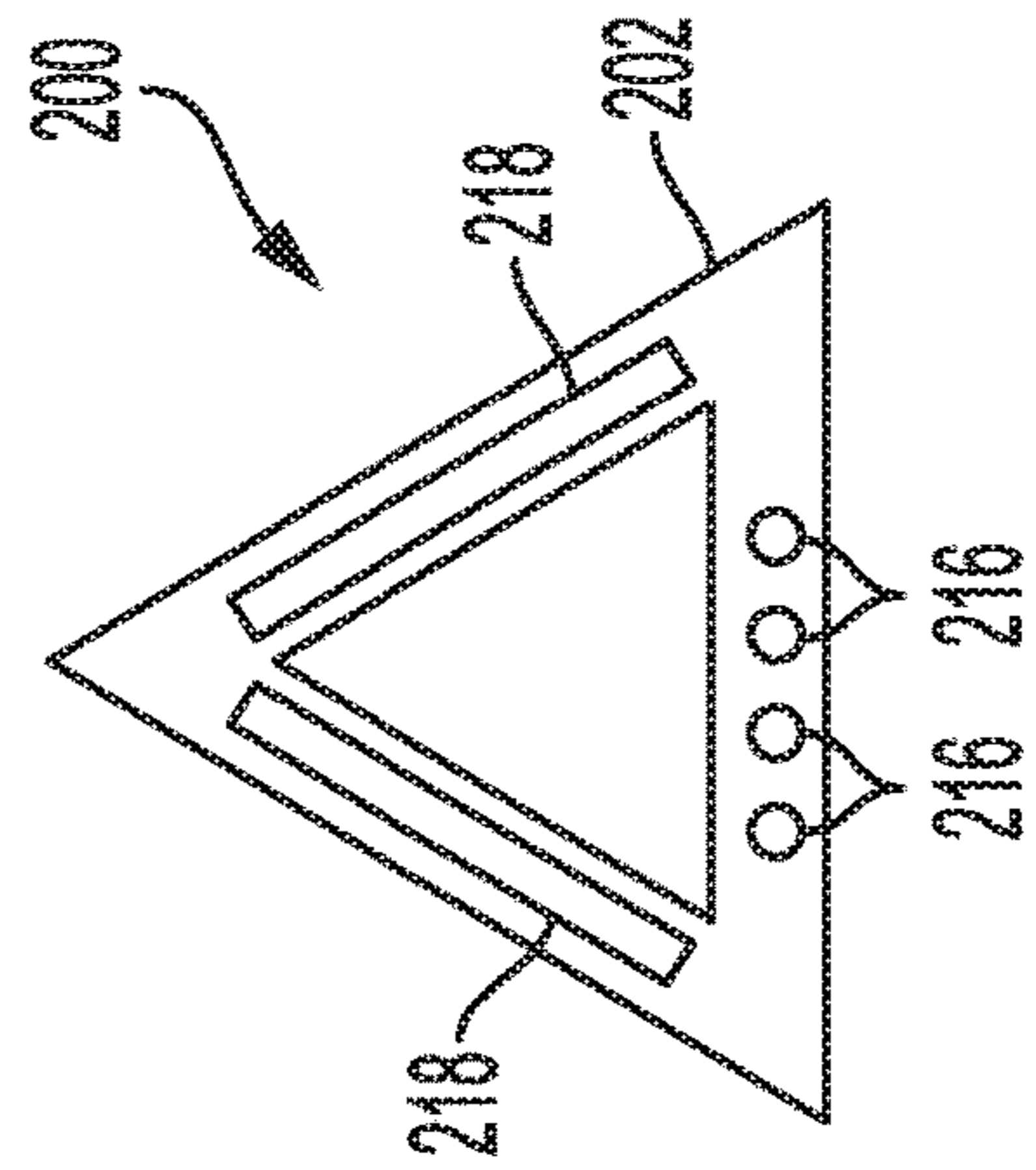

FIG. 3B

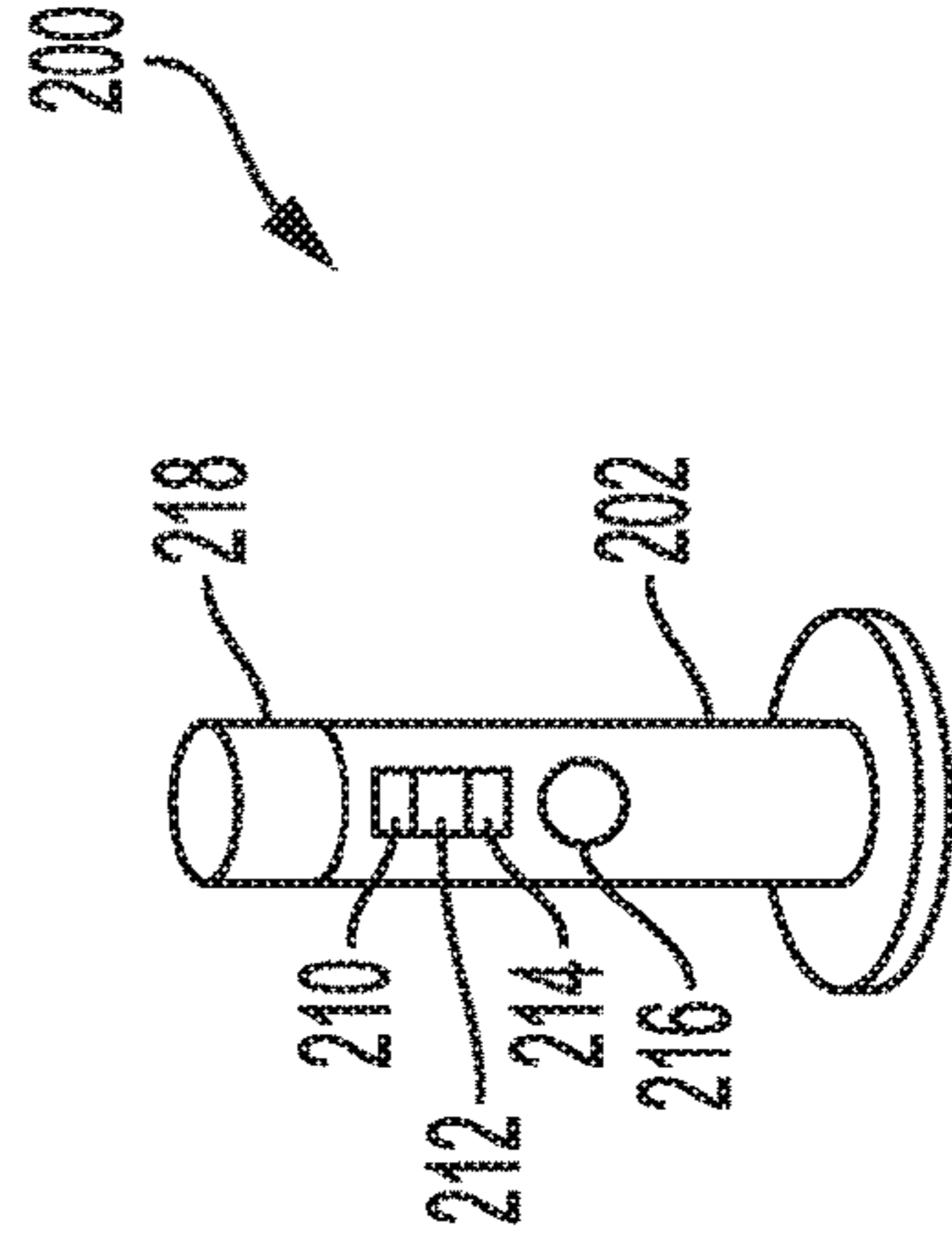

FIG. 3C

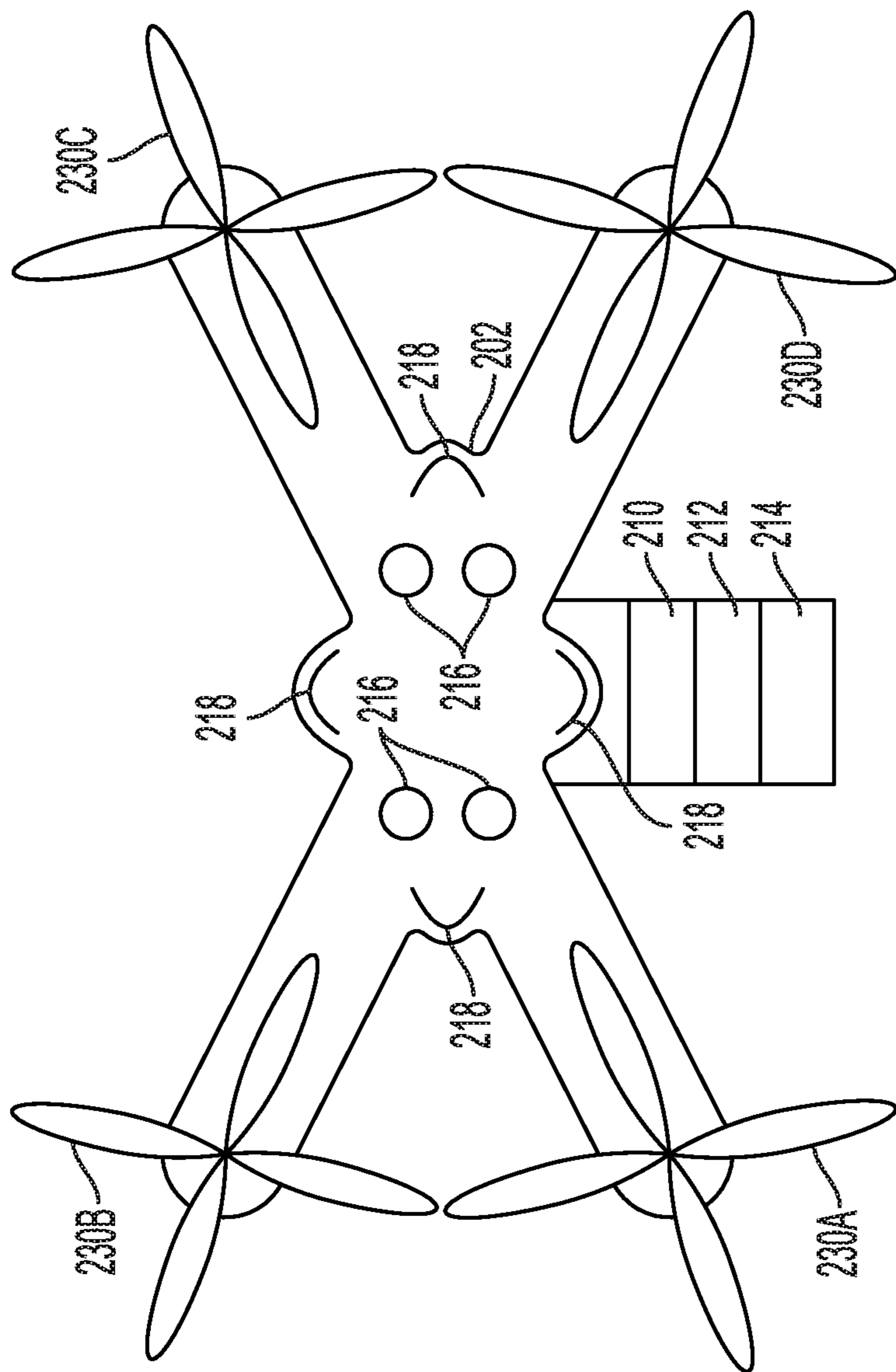

FIG. 3D

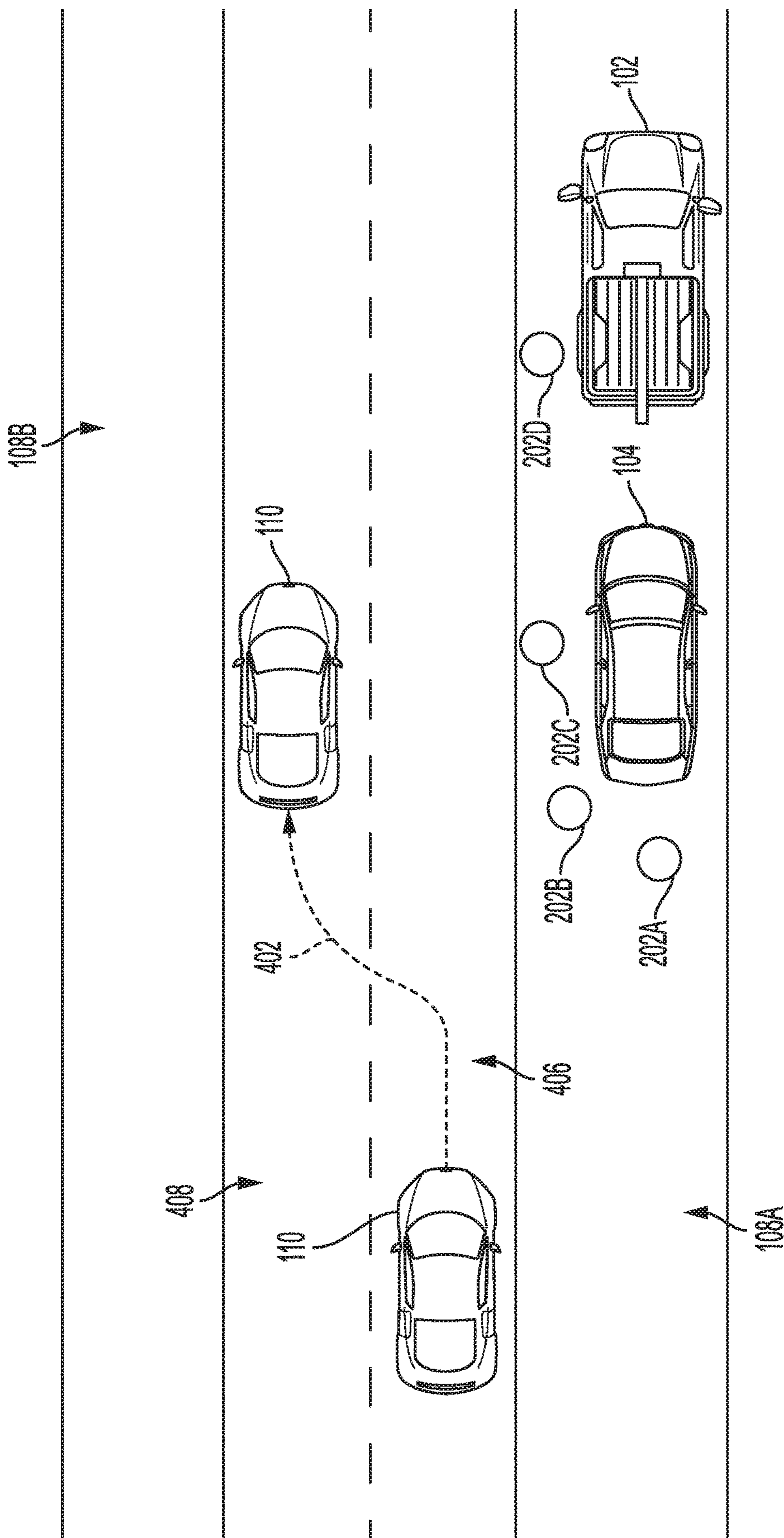

FIG. 4A

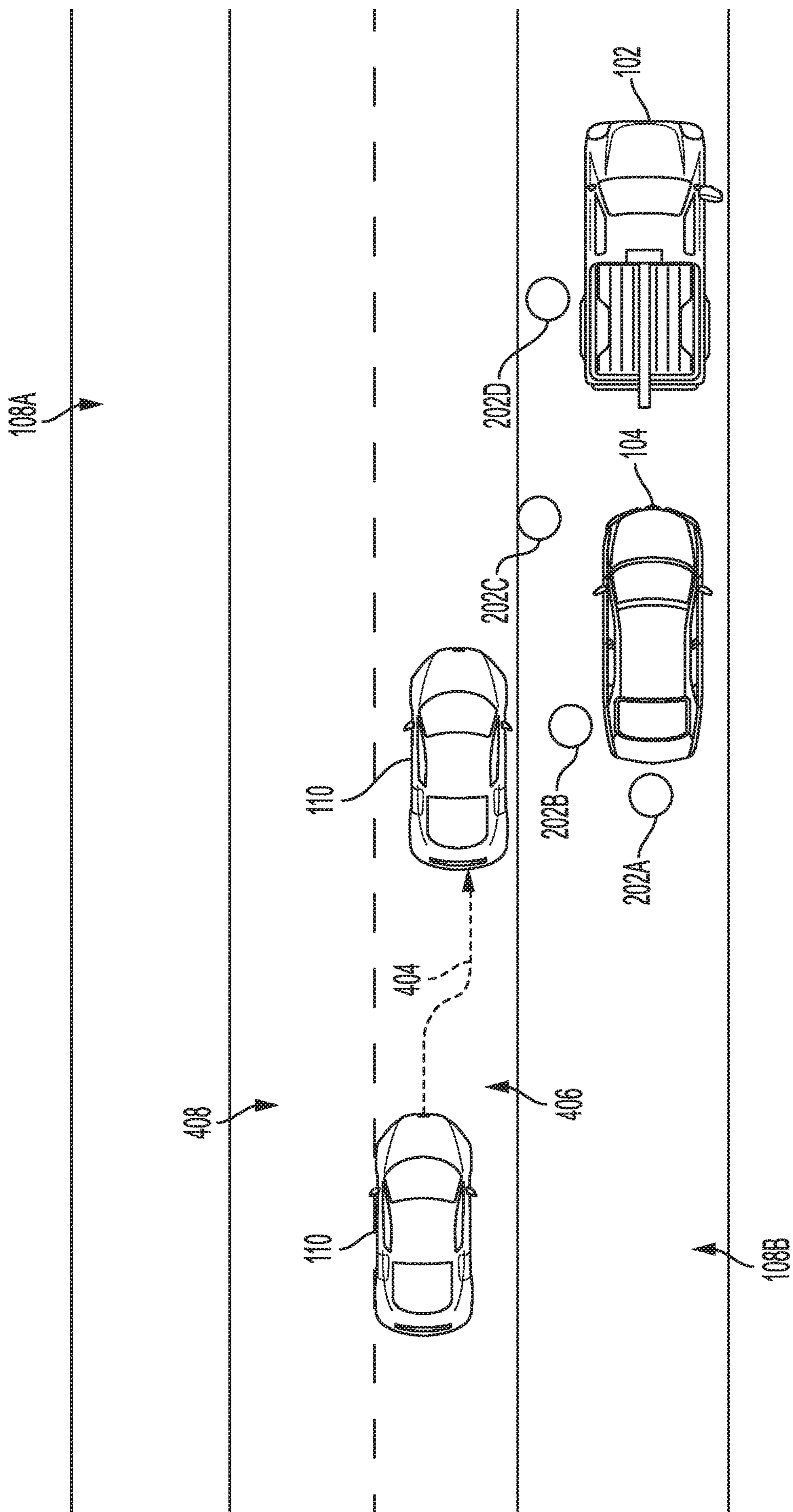

FIG. 4B

ROAD-SIDE DETECTION AND ALERT SYSTEM AND METHOD

CROSS-REFERENCE TO RELATED APPLICATIONS

[0001] This application is a continuation of U.S. application Ser. No. 16/878,272 filed May 19, 2020, the disclosure of which is hereby incorporated in its entirety by reference herein.

TECHNICAL FIELD

[0002] An alert system and method are disclosed for activating an alert when an object (e.g., approaching vehicle) is detected as traveling at a given velocity and within a given distance of a roadside alert beacon.

BACKGROUND

[0003] Each year service technicians or emergency responders are injured when assisting or approaching distressed, stopped, or parked vehicles. For instance, accidents may occur when an approaching vehicle is traveling at an undesirable velocity or within an undesirable distance from the service vehicle or distressed vehicle. To prevent accidents and to provide advance warning to approaching vehicles, roadside cones or barrels that include flashing LED lights may be employed to alert the approaching vehicles that assistance is being provided. However, conventional cones or barrels may not always effectively provide advance warning to approaching vehicles, and conventional cones and alerts do not provide warnings to the service technician or emergency responders.

SUMMARY

[0004] An alert system and method for deployment on or along a roadway. The alert system may comprise at least one alert beacon having one or more sensors (e.g., LiDAR sensor). The alert beacon further including a processor operable to poll the LiDAR sensor for a predefined number of beta readings in response to receiving an initial reading from the LiDAR sensor indicating a vehicle is within a predefined distance away from the alert beacon. The processor further being operable to calculate an average distance and an average velocity for the vehicle in response to receiving the predefined number of beta readings when the vehicle is within the predefined distance from the alert beacon. The processor also being operable to activate an audible alert and a visual alert when the average distance is below a distance threshold and the average velocity exceeds a velocity threshold in response to calculating the average distance and the average velocity.

[0005] Each alert beacon may also include one or more digital camera(s) operable to acquire one or more digital images in response to receiving the initial reading from the LiDAR sensor indicating the vehicle is within the predefined distance away from the alert beacon. The processor may also be operable to calculate a second average distance and a second average velocity for the vehicle using the one or more images. The processor may be further operable to activate the audible alert and the visual alert when the second average distance is below the distance threshold and the second average velocity exceeds the velocity threshold.

The processor may further be operable to analyze the one or more digital images to determine whether a service repair protocol is being performed.

[0006] Each alert beacon may also include a global positioning system (GPS) operable to provide a positioning data and a network interface operable to communicate with a remote server. Each processor may then be operable to transmit an identification and the positioning data of the at least one alert beacon in response to a request signal being received from the remote server. Each processor may also be operable to transmit the positioning data of the alert beacon to the remote server in response to receiving the initial reading from the LiDAR sensor indicating the vehicle is within the predefined distance away from the alert beacon. Each processor may be operable to navigate the at least one alert beacon to the geographical coordinate based on the positioning data in response to a request to deploy the at least one alert beacon to a geographical coordinate.

[0007] It is also contemplated that at least one of the alert beacons may be an aerial drone operable to hover about the geographical coordinate based on the positioning data. A mobile software application executing on a mobile device may also be operable to communicate with the at least one alert beacon. Each processor may then be operable to transmit a signal to the mobile software application to activate a visual notification and audible notification on the mobile device in response to receiving the initial reading from the LiDAR sensor indicating the vehicle is within the predefined distance away from the at least one alert beacon. Lastly, each processor may be operable to transmit a warning that is displayed upon an infotainment system within the vehicle in response to receiving the initial reading from the LiDAR sensor indicating the vehicle is within the predefined distance away from the alert beacon.

BRIEF DESCRIPTION OF THE DRAWINGS

[0008] FIG. 1 is an exemplary situation where one or more oncoming vehicles are approaching a service vehicle and distressed vehicle.

[0009] FIG. 2 is an exemplary embodiment of the roadside alert system.

[0010] FIGS. 3A-3D are exemplary embodiments of alert beacons that may be employed by the alert system.

[0011] FIGS. 4A and 4B are illustrative examples of a vehicle approaching along a predetermined path toward the alert beacons, the service vehicle, and the distressed vehicle.

DETAILED DESCRIPTION

[0012] As required, detailed embodiments of the present invention are disclosed herein; however, it is to be understood that the disclosed embodiments are merely exemplary of the invention that may be embodied in various and alternative forms. The figures are not necessarily to scale; some features may be exaggerated or minimized to show details of particular components. Therefore, specific structural and functional details disclosed herein are not to be interpreted as limiting, but merely as a representative basis for teaching one skilled in the art to variously employ the present invention.

[0013] Each year people may be injured when trying to assist or approach distressed, stopped, or parked vehicles. For instance, FIG. 1 illustrates a service vehicle 102 parked behind a distressed vehicle 104 in need of service. The

distressed vehicle **104** may be parked along one-side of a road **106** or upon a shoulder **108**. A service assistant may exit the service vehicle **102** and approach the distressed vehicle **104** to provide assistance near the road **106** or along the shoulder **108**. If the assistance requires towing the distressed vehicle **104**, the service assistant may need to connect a towing hitch to the distressed vehicle **104**.

[0014] While the service assistant is connecting the two vehicles, changing a tire, or fixing the distressed vehicle **104** in some way, the service assistant might not be aware of the location or speed of the approaching vehicles **110**. Alternatively, objects (e.g., concrete, stones, or items from approaching vehicles **110**) may project dangerously close toward the service vehicle **102** and distressed vehicle **104** where the service technician is operating. Unaware of the approaching vehicles **110** or objects, a potentially hazardous condition may arise for the service assistant, occupants within the distressed vehicle **104**, or occupants of the approaching vehicles **110**. It is therefore desirable to provide a system and method for detecting and providing advance warning when such potentially hazardous conditions arise.

[0015] FIG. 2 illustrates an alert system **200** that may be deployed for detecting and providing alerts when it is determined that an object (e.g., approaching vehicles, concrete, stones, or other items) is approaching at an undesired speed and/or path. It is contemplated that the alert system **200** may be deployed to monitor the workspace where a service technician is aiding a distressed vehicle **104** or the occupants within the distressed vehicle **104**.

[0016] The alert system **200** may include at least one alert beacon **202**. The alert beacon **202** may include at least one processor **204** that is operatively connected to a memory unit **208**. The processor **204** may be one or more integrated circuits that implement the functionality of a CPU **206** (i.e., central processing unit). The processor **204** may be a microcontroller board (e.g., Arduino microcontroller). Or, processor **204** may be a commercially available CPU that implements an instruction such as one of the x86, ARM, Power, or MIPS instruction set families.

[0017] During operation, the CPU **206** may execute stored program instructions that are retrieved from the memory unit **208**. The stored program instructions may include software that controls operation of the CPU **206** to perform the operation described herein. In some examples, the processor **204** may be a system on a chip (SoC) that integrates functionality of the CPU **206**, the memory unit **208**, a network interface, and input/output interfaces into a single integrated device. The processor **204** may implement an operating system for managing various aspects of the operation.

[0018] The alert beacon may include an electrical energy power supply **226** that may comprise a DC-battery or high-voltage capacitor. In operation, the power supply **226** may receive recharging energy from an external solar panel **228**. Alternatively, a wind turbine may provide recharging energy to the power supply **226**. It is also contemplated that power supply may be connected to an AC-energy source (i.e., 120-V AC outlet) that may be used to recharge the power supply **226**.

[0019] The memory unit **208** may include volatile memory and non-volatile memory for storing instructions and data. The non-volatile memory may include solid-state memories, such as NAND flash memory, magnetic and optical storage media, or any other suitable data storage device that retains

data when the alert system **200** is deactivated or loses electrical power. The volatile memory may include static and dynamic random-access memory (RAM) that stores program instructions and data.

[0020] The alert beacon **202** may include one or more sensors. For instance, the alert beacon **202** may include a light detection and ranging (LiDAR) sensor **210** operable to use light in the form of a pulsed laser that alert beacon **202** may use to measure a distance, velocity (using a change in distance), rate of acceleration, or velocity of an approaching objects. As discussed below, the processor **204** may be operable to algorithmically detect incoming objects and calculate their velocity in miles per hour using the data provided by the LiDAR sensor **210**.

[0021] The alert beacon **202** may also include other radar sensors **212** such as ultra-sonic radar sensors or short/medium/long-range radar sensors that are similarly operable to transmit pulsed signals that may be used by alert beacon **202** for measuring ranges (distances) from objects. The alert beacon **202** may include a digital camera **214** operable to capture images or video that may then be processed by alert beacon **202** for detecting stationary or incoming objects. The alert beacon **202** may also include a global positioning system (GPS) **215** for detecting the location of the alert beacon **202**.

[0022] The alert beacon **202** may further include one or more audible alerts **216**. The audible alerts **216** may comprise a speaker that provides a spoken warning or siren to people within a given radius of the alert beacon **202**. Or the audible alerts **216** may include multiple, unique alarms that provide different notifications to the service technician. For instance, one unique alarm may be used to alert the service technician that an approaching vehicle **110** is approaching from behind the distressed vehicle **104** and a different alert may be used for approaching vehicles **110** that may be on a path in front of the distressed vehicle **104**.

[0023] The alert beacon **202** may further include one or more visual alerts **218** to people within a given radius of the alert system **200**. For instance, the visual alert **218** may include a light system (e.g., one or more light-emitting diodes (LED)) that can provide a constant, flashing, or blinking visual warning to people. Or, the visual alert **218** may be an electronic message board that is operable to provide readable and modifiable warnings to people.

[0024] It is contemplated that the audible alerts **216** and/or the visual alerts **218** may be used to warn the occupants of the approaching vehicle **110**, the service technician, or the occupants of the distressed vehicle **104**. It is also contemplated that one or more relays may be used by the alert beacon to activate and operate the audible alerts **216** and visual alerts **218** to warn the occupants of the approaching vehicle **110**, the service technician, or the occupants of the distressed vehicle **104**. It is also contemplated that the audible alerts **216** and/or the visual alerts **218** may operate to alert the occupants (i.e., driver) of the approaching vehicle **110** to deviate course away from the alert beacon **202**, service vehicle **102**, and/or distressed vehicle **104**. Or, the audible alerts **216** and/or the visual alerts **218** may operate to alert the service technician or the occupants of the distressed vehicle **104** to move away from the approaching vehicle **110**.

[0025] The alert beacon **202** may include a network interface device **220** that is configured to provide communication with external systems and devices. For example, the network

interface device **220** may include a wired and/or wireless Ethernet interface as defined by Institute of Electrical and Electronics Engineers (IEEE) 802.11 family of standards. The network interface device **220** may include a cellular communication interface for communicating with a cellular network (e.g., 3G, 4G, 5G). The network interface device **220** may be further configured to provide a communication interface to an external network **222** or cloud.

[0026] The external network **222** may be interconnected to the world-wide web or the Internet. The external network **222** may establish a standard communication protocol between one or more external computing devices **224**. The external network **222** may allow information and data to be easily exchanged between computing devices **224** and the network interface **220**. For instance, the external devices **224** may comprise one or more servers that are in communication with alert beacon **202** via the external network **222**. Or external devices **224** may include mobile devices (e.g., smart phone, smart watch) that are in communication with alert beacon **202** via the external network **222**.

[0027] It is further contemplated that the alert system **200** may be implemented using one or more alert beacons **202**. While FIG. 2 illustrates just a single alert beacon **202**, it is intended that each of the various features and functions described above may be separated and implemented by multiple alert beacons **202**. For instance, the alert system **200** may comprise multiple alert beacons **202** each having separate sensors **210-214**, audible alerts **216**, and visual alerts **218**. Each of the alert beacons **202** may operate independently or the alert beacons **202** may be in communication and operating as a mesh network. Also, the alert beacons **202** may be in communication with a remote server (e.g., device **224**) using external network **222** that may be used to monitor or deploy the alert beacons **202**.

[0028] When multiple alert beacons **202** are employed, the alert system **200** may use external network **222** to communicate between each individual alert beacon **202**. For instance, the alert system **200** may be operable to use external network **222** to communicate between a first alert beacon **202** situated in front of the distressed vehicle **104** and a second alert beacon **202** situated behind the service vehicle **102**. Placement of multiple alert beacons **202** provides the alert system **200** with the capability of using LiDAR **210**, radar **212**, or camera **214** to scan vehicles or objects approaching in multiple directions (e.g., vehicles approaching toward the front end of the distressed vehicle **104** or from the rear-side of the service vehicle **102**). In addition, implementing multiple alert beacons **202** provides the alert system **200** with redundancy so that if one alert beacon **202** stops operating the remaining alert beacons **202** may continue operating to scan, detect, and alert about approaching vehicles **110** or objects.

[0029] The alert beacon **202** may be designed to operate in extreme weather conditions across differing geographic regions. For instance, the alert beacon **202** may be designed to operate in extreme cold or warm weather, or when exposed to rain, sleet, or snow. It is therefore contemplated that the alert beacon may be hermetically sealed or positioned within an Ingress Protection (IP) enclosure to protect the components (e.g., processor **204**, LiDAR **210**) from the various weather conditions and climate changes.

[0030] FIG. 3A-3D illustrate various exemplary alert beacons **202** that may be deployed as part of an alert system **200** for detecting and providing alerts about oncoming objects

(e.g., approaching vehicles, debris). It is contemplated that the alert beacons **202** may be deployed by a service assistant to detect potentially hazardous objects while the distressed vehicle **104** is being serviced. However, it is also contemplated that the alert beacons **202** may be deployed by police, fire, or ambulance service people providing emergency services. Or, the alert beacons **202** may be designed as commercial systems available and deployable by motorists.

[0031] Again, the alert beacon **202** may include one or more audible alerts **216** and/or visual alerts **218** operable to indicate the presence of the service vehicle **102** or distressed vehicle **104** to an approaching vehicle **110**. Or, the audible alerts **216** and/or visual alerts **218** may also be operable to indicate the presence of approaching vehicle **110** to the service assistant. As shown by FIG. 3A, the visual alert **218** may include a bucket-light light emitting display (LED) that indicates to approaching vehicle **110** the presence of the service vehicle **102** or distressed vehicle **104**. As discussed above, the audible alert **216** may be designed using a speaker system for providing an audible indication to the service assistant that the approaching vehicles **110** are approaching at an unsafe speed or distance.

[0032] It is also contemplated that the alert system **200** may operate by detecting whether an approaching vehicle **110** is within a predetermined range using data provided by the LiDAR sensor **210** or radar **212**. The processor **204** may include instructions to perform an error checking to remove any false positive data received from LiDAR sensor **210** or radar **212**.

[0033] The processor **204** may also operate on beta measurements or samples for approaching objects (i.e., approaching vehicle **110**) before determining an average distance. If processor **204** determines the measurement is not within a predefined range, the processor **204** may not store the measurements within memory **208** and/or the processor **204** may discard the measurements. The processor **204** may continue polling LiDAR sensor **210** or radar **212** until there exists a predetermined number of readings (i.e., beta readings) within a predetermined range (e.g., [Gamma, Delta] centimeters) as shown by Equation (1) below:

$$\frac{\sum_{i=1}^n x_i[\text{Gamma}, \text{Delta}]}{\text{Beta}} \quad (\text{Equation 1})$$

[0034] In Equation (1), x_i is the distance of an approaching object in centimeters (cm). Once the processor **204** calculates the average distance, the processor **204** may further calculate a velocity for the approaching object. The velocity for the approaching object may be expressed as the change in position (centimeters) divided by change in time (milliseconds) as shown by Equation (2) below:

$$\text{Velocity} = \frac{\Delta \text{ Position}}{\Delta \text{ Time}} \Rightarrow \frac{p_1 - p_0}{t_1 - t_0} \quad (\text{Equation 2})$$

[0035] Where p_i is a position at iteration i and t_i is the time at iteration i . The processor **204** may also be operable to convert the calculated velocity into miles per hour (MPH). The processor **204** may convert the calculated velocity from centimeters/milliseconds to miles/hours using Equations (3), (4), (5) below:

$$\text{Miles} = \frac{\text{Centimeters}}{30.48} \div 5280 \quad (\text{Equation 3})$$

$$\text{Hours} = \frac{\text{Milliseconds}}{1000} \div 3600 \quad (\text{Equation 4})$$

$$\text{MPH} = \frac{\text{Miles}}{\text{Hours}} \quad (\text{Equation 5})$$

[0036] Processor **204** may also determine if the velocity of the object (i.e., approaching vehicle **110**) is moving at a speed greater than or equal to a predetermined velocity (e.g., 25 MPH) and whether the velocity of the object is at a distance less than or equal to a predetermined distance (e.g., 3000 cm) as shown by Equation (6) below:

$$z = f(x, y) = \begin{cases} \text{true, } x > 25 \text{ and } y \leq 3000 \\ \text{false, } x < 25 \text{ and } y \geq 3000 \end{cases} \quad (\text{Equation 6})$$

[0037] Where z may be an output indicating whether an audible alert **216** or visual alert **218** should be activated, x is speed in miles per hour (MPH), and y is distance in centimeters (cm). If the processor **204** determines the object is within the predetermined velocity and distance, then the processor may activate the visual alert **218** (e.g., LED light) or audible alert **216** (e.g., loud siren).

[0038] FIG. 3A also illustrates that the alert beacon **202** may include multiple LiDAR sensors **210A-210C**, multiple radar sensors **212A-212C**, and multiple cameras **214A-210C**. The LiDAR sensors **210A-210C**, radar sensors **212A-212C**, and cameras **214A-210C** may be located at various positions around the alert beacon **202**. By including multiple LiDAR sensors **210A-210C**, radar sensors **212A-212C**, and cameras **214A-210C** the alert beacon **202** may be operable to scan approaching objects or vehicles in all directions. For instance, the alert beacon **202** may use the multiple LiDAR sensors **210A-210C**, radar sensors **212A-212C**, and cameras **214A-210C** to scan all approaching vehicles **110** regardless of which direction they may be approaching the service vehicle **102** or distressed vehicle **104**. It is also contemplated that only one set of LiDAR, radar and camera (e.g., **210A**, **212A**, **214A**) may be included and may be designed to rotate around the alert beacon **202** to scan for approaching objects or vehicles in all directions.

[0039] As illustrated in FIG. 3A, alert beacon **202** may be designed or shaped as a traffic cone. It is contemplated, however, that the alert beacon **202** may be shaped or deployed in other forms or manners dependent upon a given application. For instance, FIG. 3B illustrates the alert beacon **202** designed as a roadside emergency triangle. As shown by FIG. 3B, multiple visual alerts **218** (e.g., LED lighting system) may be included to provide visual alert to approaching traffic, service assistants, or bystanders. FIG. 3B also illustrates that multiple audible alerts **216** may be included within alert beacon **202**. Depending upon the size or application of the alert beacon **202**, additional audible alerts **216** and visual alerts **218** may be desired. FIG. 3C further illustrates the alert beacon **202** designed as a roadside cylinder.

[0040] FIG. 3D illustrates the alert beacon **202** may also be designed as an aerial drone. As used within this application, the term “drone” may refer to an aerial vehicle capable to operating autonomously to perform a predeter-

mined function, or the aerial vehicle may be controlled by the human operator. The alert beacon **202** may include one or more thrust devices **230A-230D**. As shown, the plurality of thrust devices **230A-230D**, are arranged about the periphery and include propeller members that rotate to produce thrust. The thrust devices **230A-230D** may be configurable to provide both lift (vertical thrust) and lateral thrust (horizontal thrust). The vertical and horizontal components of the thrust allow the changing of the altitude, lateral movement and orientation (attitude) of the alert beacon **202**.

[0041] Lastly, it is contemplated that the alert beacon **202** may also be designed as a clothing article or an IoT device that a service technician may wear when assisting a distressed vehicle **104**. The alert system **200** may still provide wireless connectivity between the alert beacon **202** (i.e., clothing article or IoT device) worn by the service technician and additional alert beacons **202** positioned around the service vehicle **102** and distressed vehicle **104**. However, it is also contemplated that the clothing article or IoT device may be an alternative form of the alert system **200** independent of the alert beacons **202** illustrated by FIGS. 4A-4D.

[0042] For instance, the clothing article may be a vest worn by the service technician. The vest may include one or more LiDAR sensors or radar sensors for detecting the location and speed of approaching vehicles **110** or objects. The vest may also include one or more camera sensors for detecting and recording video. The vest may be operable to determine if an oncoming vehicle is approaching within a predetermined distance or speed of the service vehicle **102** or distressed vehicle **104**. The vest may include audible and visual alerts that may then be activated to notify the service technician about the approaching vehicle **110** or object. If employed as wearable glasses or contact lenses, the alert system **200** could display visual alerts to the service technician. Or, the clothing article may be a smart watch (e.g., Android watch or Apple watch) where a mobile software application could be utilized on smart watches to provide visual or audible alerts to the service technician.

[0043] FIG. 4A illustrates an alert system **200** with numerous alert beacons **202A-202D** situated around the service vehicle **102** and the distressed vehicle **104**. It is contemplated that the service technician may deploy and situate the alert beacons **202A-202D** in a vicinity surrounding the service vehicle **102** and the distressed vehicle **104**. Or, each alert beacon **202A-202D** may include a motor and wheels that allow automatic deployment from the service vehicle **102**. The alert system **200** may therefore automatically position the alert beacons **202A-202D** in a vicinity surrounding the distressed vehicle **104** without assistance from the service technician.

[0044] It is contemplated, however, that the service technician may manually control placement of the alert beacons **202A-202D** using network interface **220**. For instance, the service technician may use a mobile device or remote control that is wirelessly connected to each alert beacon **202A-202D** through the network interface **220**. The service technician may use, for instance, a mobile app that allows selection of each alert beacon **202A-202D**. Following selection of the alert beacon **202A-202D**, the mobile app may provide the service technician with the capability of controlling placement of the alert beacon **202A-202D**.

[0045] Again, each alert beacon **202A-202D** may be an aerial drone as illustrated by FIG. 3D that is operable to hover above the vicinity of the service vehicle **102** and the

distressed vehicle **104**. When deployed using an aerial drone, the alert beacons **202A-202D** may also be situated above the first lane **406**, second lane **408**, or the roadside shoulders **108A, 108B**. When the drone is hovering above approaching vehicles **110**, the visual alerts **216** (e.g., LED lights) may be visible at a greater distance away from the service vehicle **102**. The visual alert **216** may be a flashing light that when activated may be visible by approaching vehicle **110** for distances greater than $\frac{1}{4}$ of mile. The increased visibility may be because the drone is not obstructed by other vehicles or roadside obstacles.

[0046] It is also contemplated that each alert beacon **202A-202D** also includes a motorized assembly (not shown) that is controlled by processor **204** to self-level the LiDAR **210**, radar **212**, and camera **214** regardless of the road grade. For instance, the processor **204** may be programmed to: (1) scan downward until the ground is detected; (2) scan upward to detect a horizon; and (3) auto-level the LiDAR **210** at a position that projects toward the approaching vehicle **110**. Or the processor may provide self-leveling using an accelerometer to determine a specific orientation of the LiDAR **210**, radar **212**, and camera **214** and to measure different values of downward acceleration due to gravity.

[0047] It is further contemplated each alert beacon **202A-202D** may be physically attached to the service vehicle **102**. For instance, each alert beacon **202A-202D** may be attached to a light bar atop the service vehicle **102** or through equipment attached inside or outside the service vehicle **102**. The LiDAR **210**, radar **212**, and camera **214** may also be positioned around the service vehicle **102** and may be used by processor **204** to detect approaching vehicles **110** approaching from various directions. The LiDAR **210**, radar **212**, and camera **214** may also be controlled by the service technician or may automatically be activated in conjunction with traffic flow and road position.

[0048] As shown by FIG. 4A, the alert beacons **202A-202D** may be positioned behind the service vehicle **102** and near the edge of the shoulder **108**. An approaching vehicle **110** may initially be approaching in a first lane **406** toward the alert beacon **202**. But as the approaching vehicle **110** is alerted to the alert beacon **202**, the approaching vehicle **110** may be steered along first path **402** into the second lane **408**. It is contemplated that the approaching vehicle **110** may be steered into the second lane **308** once the visual alert **218** (e.g., LED bucket light) is seen by the driver. Or, the oncoming vehicle **110** could send a message to the vehicle, phone or IOT device to move over into the second lane. Or, the approaching vehicle **110** may be autonomously controlled and may be steered into the second lane **408** based on sensed or received data that is transmitted by alert system **200**. Having been repositioned into the second lane **408**, the alert system **200** may not activate audible alert **216**.

[0049] However, as shown by FIG. 4B, the approaching vehicle **110** may not deviate from the first lane **406**. Instead, the approaching vehicle **110** may travel along second path **404** approaching near alert beacon **202**. The approaching vehicle **110** may approach closer to alert beacon **202** even though visual alert **218** has been activated and is operating to alert the occupants of the approaching vehicle **110**. Once the approaching vehicle **110** reaches a predetermined distance or velocity from alert beacon **202** the audible alert **318** may be activated to alert the service technician. The audible alert **318** may be alerted when approaching vehicle **110** has reached a predetermined distance or velocity such that the

service technician would have enough time to reposition themselves, and possibly warn occupants of the distressed vehicle **104**.

[0050] It is also contemplated that the camera **214** may be operable to provide video recording of the area surrounding the distressed vehicle **104**. The camera **214** may be operated whenever an alert beacon **202** is deployed. Or, the camera **214** may only be operable to record video when an approaching vehicle **110** is determined as moving above a predetermined velocity (i.e., speed) or within a predetermined direction of the distressed vehicle **104**, service vehicle **102**, or alert beacon **202**. The predetermined velocity and direction values may be stored within memory **208**. The predetermined direction and velocity values may be calibratable or may be adjusted by the service technician. The alert beacon **202** may also be operable to record and store the digital images, recorded video, or video segments acquired from camera **214** within memory **208** or stored in external network **222**. Additionally, the camera **214** may also be used by the processor **204** in conjunction with a machine learning algorithm to determine if the service technicians are following a predetermined series of safety or operational protocols while assisting occupants of the distressed vehicle **104**.

[0051] The alert system **200** may also be operable to transmit the video using external network **222** to a remote storage (e.g., device **224**) that may be located within service vehicle **102**. Or, the alert beacon **202** may operably transmit the video using external network **222** to a remote server (e.g., Corporate Server or cloud-based storage like Amazon Web Services). The transmitted video may then be observed by remote workers either while service is being provided, or at a later time. The remote workers may observe the video to provide supervision and oversight for the work being performed by the service technician. Or the remote workers may observe the video as an extra level of safety for the service technician and the occupants of the distressed vehicle **104**. Video and GPS positions could be live streamed via network interface **220** and external network **224** to a central location allowing supervisors and fleet operators the ability to oversee operations in real time.

[0052] The alert system **200** may also be operable to process the real time traffic analytics stored within memory **208** using the video collected from camera **214**. Traffic analytics may again be transmitted using external network **222** to central system or cloud-based storage (e.g., device **224**) that may be monitoring multiple alert systems **200** (i.e., multiple emergency service vehicles) distributed across various locations. Traffic analytics data could be used both internally and externally to provide more accurate information to service technicians and to motorists.

[0053] Data from the GPS **215** may likewise be transmitted to the monitoring service or emergency service (via external network **222**) when processor **204** determines the approaching vehicle **110** is approaching at a given speed, distance, or path toward the service vehicle **102**, distressed vehicle **104**, or alert beacon **202**. The data provided by the GPS **215** may also be processed for internal analytics regarding prevalent distressed vehicle locations.

[0054] The alert system **200** may also be operable to transmit an alert using external network **222** to an infotainment system, heads-up display, video monitor, or mobile device located within an approaching vehicle **110**. For instance, the alert system **200** may also employ external network **222** to provide geo-fencing capabilities that can

provide the alert within the oncoming vehicles. The alert system 200 may transmit to the approaching vehicle 110 over the external network 222 data indicating the location of the service vehicle 102, distressed vehicle 104, or the alert beacon 202. The alert system 200 may also receive from the external network 222 data indicative of the location of the approaching vehicle 110. The alert system 200 may determine when to activate the audible alert 216 or the visual alert 218 based on the location and velocity of the approaching vehicle 110 in relation to the service vehicle 102, distressed vehicle 104, or the alert beacon 202. It is further contemplated that the alert system may be in communication with mobile software applications that may then provide route information to drivers and give real-time traffic information to advise occupants of the approaching vehicles 110.

[0055] The alert system 200 may also transmit instructions from network interface 220 over external network 222 to slow a given speed of approaching vehicles 110. For instance, the alert system 200 may transmit data or instructions over external network 222 notifying local emergency services regarding the distressed vehicle 104. The local emergency services may be equipped to transmit a notification signal to approaching vehicles 110 nearing the proximity of the distressed vehicle 104 (e.g., ¼ mile radius). Upon receiving the notification signal, the approaching vehicles 110 may be programmatically controlled to reduce to a specified speed (e.g., 25 MPH) regardless of whether the driver attempts to depress the accelerator pedal. It is contemplated that notification signal may not be required as coming from an emergency service location but could be transmitted by alert system 200 or monitoring service that is in communication with alert system 200.

[0056] It is also contemplated that the alert system 200 may transmit notification signals operable to initiate automatic braking or collision avoidance within the approaching vehicles 110. For instance, the notification signals may be used to provide automatic braking within approaching vehicles 110 that are approaching within a predetermined velocity or distance to the alert beacon 202, service vehicle 102, or distressed vehicle 104. Or, the notification signal may be used to steer the approaching vehicle 110 away from the alert beacon 202, service vehicle 102, or distressed vehicle 104.

[0057] The alert system 200 may further be operable to use external network 222 to connect with a roadside billboard or municipal notification system to provide additional alerts to approaching vehicles 110. For instance, many roadside billboards are now equipped as video electronic displays. The alert system 200 may be operable to connect with such billboards (either directly or through a notification service) using the external network 222 so that information may be provided to approaching vehicles 110. Many cities are also equipped with electronic signage that may be used to alert the approaching vehicles 110 about current traffic conditions. These electronic signs may also be used by the alert system 200 to notify approaching vehicles 110 about the location of the service vehicle 102, distressed vehicle 104, or the alert beacon 202.

[0058] The alert system 200 may also be operable to connect using external network with a mobile device worn by the service technician. For instance, the alert system 200 may include a mobile software application that may be downloaded on a mobile device (e.g., app available and downloadable onto an Apple or Android smart phone). The

mobile software application may employ audible or visual alert capabilities of the mobile device to alert the service technician when it is determined that the velocity of an approaching vehicle 110 is above a predetermined threshold, or the direction of an approaching vehicle 110 is within a predetermined distance.

[0059] The alert system 200 may be integrated to operatively use sensors or alert systems located within a service vehicle 102. Or, the alert system 200 may integrate, or alternatively rely on, sensors located within a distressed vehicle 104. For instance, the distressed vehicle 104 may be operable to include functionality that allows service technician to connect the alert system 200 to sensors (e.g., LiDAR, cameras) positioned within the distressed vehicle 104. The sensors located within the distressed vehicle 104 may then be implemented by the alert system 200 to further detect and provide alerts about approaching vehicles 110 or objects.

[0060] The alert system 200 may also transmit to external network 222 data indicative of traffic patterns surrounding the distressed vehicle 104. Or the alert system 200 may transmit instructions requesting re-routing of traffic away from the distressed vehicle 104. The data and instructions may be provided to mapping software providers (e.g., Google or Waze) so that approaching vehicles 110 may be informed and/or re-routed away from the distressed vehicle 104. For instance, the alert system 200 may request that approaching vehicles 110 be re-routed a given distance (e.g., ½-mile) away from distressed vehicle 104.

[0061] It is further contemplated that the area surrounding the distressed vehicle 104 may have moveable traffic flow devices. For instance, certain roadways include lane diversion systems that permit for an additional or alternative traffic lane. Alert system 200 may activate and use this additional or alternative traffic lane to re-route approaching vehicles 110 away from distressed vehicle 104 to provide safe working environment for service technician.

[0062] The alert system 200 may also be designed to receive information regarding the location where the distressed vehicle 104 is located. For instance, the distressed vehicle 104 may be located in a highly traversed area, an area that includes visual obstructions for approaching vehicles 110 (e.g., bridges, bushes), or a location that does not include suitable space to service the distressed vehicle 104 (e.g., an area with a small or no shoulder). The alert system 200 may be operable to evaluate and determine if the distressed vehicle 104 is located at an area that is unsafe for the service technician. The alert system 200 may be operable to alert the distressed vehicle 104 to proceed to different location prior to being serviced.

[0063] It is also contemplated that the alert system 200 may operably receive from external network 222 data from local weather services about pending weather conditions surrounding the distressed vehicle 104. If the alert system 200 determines that the received data about the weather conditions may increase the potential for accidents with approaching vehicles 110 additional safety measures may be employed. For instance, if the alert system 200 receives data about a severe snow storm or that there exists icy road conditions around the distressed vehicle 104, the alert system 200 may require increased coverage by the alert beacons 202 surrounding the distressed vehicle 104. The radius and number of the alert beacons 202 may also be increased to ensure the alert system 200 can provide advanced alert warnings to the service technician. The alert system 200 may

also operably employ a machine learning algorithm so that the service vehicle **102** could access telematics data to determine any deterioration in alert beacons **202** which would lead to a breakdown or equipment failure.

[0064] It is further contemplated that the alert system **200** may implement a facial recognition algorithm, blockchain algorithm, optical character recognition (OCR), or image recognition for tracking and detecting potential misplacement or theft of any one of the alert beacons **202**. For instance, an alert beacon **202** may be taken from the roadside or from the back of a service vehicle **102**. Using the network transmitter **220**, the processor **204** may transmit digital images acquired by the camera **214**. A facial recognition algorithm may be employed by processor **204** to identify the individual responsible for taking the alert beacon **202**. Also, the processor **204** may employ GPS data from GPS **215** to determine and transmit the location of the alert beacon **202** for retrieval by authorities.

[0065] The processor **204** may also employ camera **214** to acquire images of the license plates from oncoming vehicles **110**. The alert system **200** may use external network **222** to communicate with an external server (e.g., police database) or emergency services when it is determined that an acquired license plate is that of a stolen or missing vehicle. The alert system **200** may detect when a stolen or missing vehicle using the image acquired by the camera **214**. The alert system **200** may send a notification (using external network **222**) to the local authorities (e.g., police department) with a location where the stolen or missing vehicle was identified. Should the alert system **200** be unable to capture license plates, it may still capture images of vehicles and use object/color detection to get the make, model and color of the stolen or missing vehicle.

[0066] The LiDAR sensor **210**, radar sensor **212**, camera **214**, and GPS **215** may also be used to create a surface or topographical map pertaining to where the distressed vehicle **104** is situated. The surface/topographical map may be used by the alert system **200** to detect for hazardous road conditions or obstacles. The alert system **200** may then provide alerts to the service technician if a road condition or obstacle may present a dangerous work environment. For instance, the surface map may indicate that a large pothole exists near the distressed vehicle **104**. The alert system **200** may provide an audible or visual warning to the service technician about the pothole. The service technician may then use the alert to add additional alert beacons **202** around the service vehicle **102** or distressed vehicle **104** to ensure that approaching vehicles **110** avoid the obstacle (e.g., pothole).

[0067] The alert system **200** may also be operable to store the locations, topographical data, and weather conditions within memory **208** when servicing a distressed vehicle **104**. The alert system **200** may use this information to generate analytical data about common locations where a distressed vehicle **104** requires service. If a given location routinely involves a distressed vehicle **104** requiring service, the alert system **200** may notify local authorities. The alert system **200** may also provide local authorities with data regarding potential reasons why there are increased numbers of distressed vehicles **102** in a given location. For instance, the alert system **200** may be operable to assess analytical data that includes topographical, satellite images, or surface maps acquired from the LiDAR sensor **210**, radar **212**, camera **214**, or GPS **215** to determine that a given location may include several large potholes. The alert system **200** may be

operable to transmit the analytical data using network interface **220**. The analytical data may be received by local authorities that can use the information to correct or rectify the pothole.

[0068] The alert system **200** may further employ a microphone (e.g., within the camera **214**) to record and analyze the voice analytics during which a service technician is servicing a distressed vehicle **104**. The voice analytics may then be further processed to determine the satisfaction of the customer while the distressed vehicle is being serviced. If the alert system **200** determines a positive customer satisfaction, the alert system **200** may be enabled to provide a post to a social networking website (e.g., LinkedIn or Facebook) about the service technician and the work performed. Also, the alert system **200** may further be enabled to track the response time and time required to service a distressed vehicle **104**. Again, the alert system **200** may then be operable to post updates to social networking websites about the response or service times. Or the time update may be used to inform another potential customer about their expected wait time.

[0069] It is further contemplated that occupants of the distressed vehicle **104** may be able to fill out an application process that is accessible using external network **222** by the alert system **200**. The application process may be part of an enrollment system with an insurance agent (e.g., AAA of Michigan). The application process may include emergency contact information. The alert system **200** may be operable to provide alerts to the emergency contacts when the alert system **200** is deployed for the occupants of the distressed vehicle **104**.

[0070] While exemplary embodiments are described above, it is not intended that these embodiments describe all possible forms of the invention. Rather, the words used in the specification are words of description rather than limitation, and it is understood that various changes may be made without departing from the spirit and scope of the invention. Additionally, the features of various implementing embodiments may be combined to form further embodiments of the invention.

What is claimed is:

1. An alert system deployable on or along a roadway comprising:
 - at least one alert beacon including:
 - a distance sensor;
 - a processor operable to:
 - in response to receiving an initial reading from the distance sensor indicating a vehicle is within a predefined distance away from the alert beacon, poll the distance sensor for a predefined number of beta readings;
 - in response to receiving the predefined number of beta readings when the vehicle is within the predefined distance from the alert beacon, calculate an average distance and an average velocity for the vehicle; and
 - in response to calculating the average distance and the average velocity, activate an audible alert and a visual alert when the average distance is below a distance threshold and the average velocity exceeds a velocity threshold.
2. The alert system of claim 1, wherein the at least one alert beacon further includes:
 - a digital camera operable to acquire one or more digital images;

the processor being further operable to:
 in response to receiving the initial reading from the distance sensor indicating the vehicle is within the predefined distance away from the alert beacon; acquire one or more images of the vehicle; calculate a second average distance and a second average velocity for the vehicle using the one or more images; and activate the audible alert and the visual alert when the second average distance is below the distance threshold and the second average velocity exceeds the velocity threshold.

3. The alert system of claim **2**, wherein the processor is further operable to: analyze the one or more digital images to determine whether a service repair protocol is being performed.

4. The alert system of claim **1**, wherein the at least one alert beacon further include a global positioning system (GPS) operable to provide a positioning data, and a network interface operable to communicate with a remote server.

5. The alert system of claim **4**, wherein the processor is further operable to: in response to a request signal being received from the remote server, transmit an identification and the positioning data of the at least one alert beacon.

6. The alert system of claim **4**, wherein the processor is further operable to: in response to receiving the initial reading from the distance sensor indicating the vehicle is within the predefined distance away from the alert beacon, transmit the positioning data of the alert beacon to the remote server.

7. The alert system of claim **4**, wherein the processor is further operable to: in response to a request to deploy the at least one alert beacon to a geographical coordinate, navigate the at least one alert beacon to the geographical coordinate based on the positioning data.

8. The alert system of claim **7**, wherein the at least one of the alert beacon is an aerial drone operable to hover about the geographical coordinate based on the positioning data.

9. The alert system of claim **1**, wherein a mobile software application executing on a mobile device is operable to communicate with the at least one alert beacon.

10. The alert system of claim **9**, wherein the processor is further operable to: in response to receiving the initial reading from the distance sensor indicating the vehicle is within the predefined distance away from the at least one alert beacon, transmit a signal to the mobile software application to activate a visual notification and audible notification on the mobile device.

11. The alert system of claim **1**, wherein the processor is further operable to: in response to receiving the initial reading from the distance sensor indicating the vehicle is within the predefined distance away from the alert beacon, transmit a warning that is displayed upon an infotainment system within the vehicle.

12. A method for operating an alert system that is deployable on or along a roadway, comprising:
 polling one or more sensors for a predefined number of beta distance readings in response to receiving an initial distance reading from at least one of the sensors indicating a vehicle is within a predefined distance away from an alert beacon;
 calculating an average distance and an average velocity for the vehicle in response to receiving the predefined number of beta distance readings when the vehicle is within the predefined distance from the alert beacon;
 and

activating one or more alerts when the average distance is below a distance threshold and the average velocity exceeds a velocity threshold in response to calculating the average distance and the average velocity.

13. The method of claim **12**, further comprising:
 acquiring one or more images of the vehicle from a digital camera in response to receiving the initial distance reading from the one or more sensors indicating the vehicle is within the predefined distance away from the alert beacon;
 calculating a second average distance and a second average velocity for the vehicle using the one or more images; and
 activating the one or more alerts when the second average distance is below the distance threshold and the second average velocity exceeds the velocity threshold.

14. The method of claim **13**, further comprising: analyzing the one or more images to determine whether a service repair protocol is being performed.

15. The method of claim **13**, further comprising: transmitting an identification and a positioning data of the alert beacon provided by a global positioning system (GPS) in response to a request signal being received from a remote server.

16. The method of claim **15**, further comprising: transmitting the positioning data of the alert beacon to the remote server in response to receiving the initial distance reading from the one or more sensors indicating the vehicle is within the predefined distance away from the alert beacon.

17. The method of claim **15**, further comprising: navigating the alert beacon to a geographical coordinate based on the positioning data in response to a request to deploy the alert beacon to a geographical coordinate.

18. The method of claim **12**, transmitting a signal to a mobile application to activate a visual notification and audible notification on a mobile device in response to receiving the initial distance reading from the one or more sensors indicating the vehicle is within the predefined distance away from the alert beacon.

19. An alert beacon deployable on or along a roadway comprising:
 a controller operable to:
 in response to determining a vehicle is within a predefined distance away from the alert beacon, polling one or more sensors for a predefined number of beta distance readings;
 in response to receiving the predefined number of beta distance readings when the vehicle is within the predefined distance from the alert beacon, calculate an average distance and an average velocity for the vehicle; and
 in response to calculating the average distance and the average velocity, activate an alert when the average distance is below a distance threshold and the average velocity exceeds a velocity threshold.

20. The alert beacon of claim **19** further comprising:
 a digital camera operable to acquire one or more digital images;
 the controller is further operable to:
 in response to receiving an initial reading from the one or more sensors indicating the vehicle is within the predefined distance away from the alert beacon; acquire one or more images of the vehicle; calculate a second average distance and a second average velocity for the

vehicle using the one or more images; and activate the one or more alerts when the second average distance is below the distance threshold and the second average velocity exceeds the velocity threshold.

* * * * *