



ASTON MARTIN



Welcome

Welcome to your new Aston Martin Valkyrie.

This Owner's Handbook has been designed to explain the vehicle's operation and to make the control of its systems easy to understand and operate. All new owners are recommended to read the Owner's Handbook prior to driving. This Owner's Handbook forms part of the essential vehicle equipment for homologation purposes and must stay with the vehicle at all times.

Warnings, Cautions and Notes

The following Warnings, Cautions and Notes are used within this Owner's Guide to call your attention to specific types of information.

 **Warning: Provided to show procedures which must be followed precisely to help avoid the risk of personal injury.**

 **Caution: Provided to show procedures which must be followed precisely to reduce the possibility of damage to your vehicle.**

 *Provided to show procedures which will help to avoid difficulties in the operation of your vehicle.*

Data Telematics

Vehicle Identification

The Vehicle Identification Number (VIN) is shown in the left side bottom corner of the windscreen.

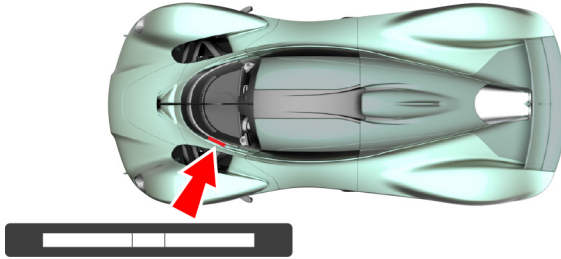

The VIN can also be found on the build labels behind the seats and right side door shut, as well as the engine and the transmission.

This vehicle uses telematics to monitor various systems and parameters on the vehicle to aid remote diagnosis such as:

- Information about the performance of various systems and modules in the vehicle.
- Information related to engine, throttle, steering, brake, high voltage battery or other system status.

Any of these systems can include information on how the driver operates the vehicle, measuring vehicle speed, steering input, brake and throttle application. This information will be monitored and may be stored under regular operation, in a crash or in a near crash event.

This information can be read and used by:

- Aston Martin
- Rimac Automobil
- Service and repair facilities
- Law enforcement or government agencies
- Others who may assert a right or obtain your consent to know such information.

Customer Privacy

The telematics program is automatically included with the vehicle, however you may opt out at any time. To have the telematics monitoring function on your vehicle disabled, contact an Aston Martin Dealer.

Reporting Safety Defects

If you believe that your vehicle has a safety defect which could cause a crash or could cause injury or death, you should immediately inform your Aston Martin Dealer or the Aston Martin Client Services at the address shown.

UK

Aston Martin Lagonda Limited
Client Services
Banbury Road
Gaydon
Warwick
CV35 0DB
England
Telephone:
+44 (0)1926 644700

European Representative

Aston Martin Lagonda of Europe GmbH
Unterschweinstiege 2-14
60549 Frankfurt
Germany

Driving Safety

- Always wear your seat belt.
- Never drive under the influence of alcohol or drugs.
- Always obey all speed and traffic laws and regulations. Never drive faster than the posted speed limit or than conditions allow.
- Be particularly careful driving on slippery or wet surfaces.
- This vehicle is a high performance vehicle and has handling characteristics you may not be accustomed to. Familiarise yourself with the vehicle and always drive prudently, being aware of your own limitations and the limitations of the vehicle. As with other vehicles of this type, failure to operate the vehicle correctly can result in accident and injury.
- Follow the maintenance schedule approved in this guide.
- Never allow the vehicle to be driven by inexperienced drivers.

 *Make sure that you are wearing appropriate footwear to efficiently operate the control pedals. Make sure that pedal movement is not restricted by floor mats or other objects trapped beneath pedals.*

Aston Martin Heritage Trust

The Aston Martin Heritage Trust is an educational charity dedicated to the preservation, promotion and enhancement of over 100 years of history of Aston Martin. Its world class collection comprising the automotive museum, substantial archive and collection of historical artefacts is housed in the magnificently restored Grade II* listed barn in Oxfordshire which it shares with the Owners' Club. As a member of the Owners' Club you become a member and supporter of the Trust, so please log on to our web site for more information, or better still pay us a visit and see the collection for yourself.

Aston Martin Heritage Trust
Drayton St. Leonard
Wallingford
Oxfordshire
England
OX10 7BG

Telephone: +44 (0) 1865 400 414

E-Mail: secretary@amht.org.uk

Website: www.amht.org.uk



Aston Martin Owners' Club (AMOC)

An invitation to join the Aston Martin Owners' Club

The sporting spirit of the 1930s exists today in one of the world's most exclusive car clubs. Enthusiasts in nearly 60 countries are united by an interest in iconic cars with an enviable pedigree. Enjoy the company of like-minded owners in a wide range of activities: social evenings, weekends away or motoring tours. Something more competitive? AMOC Concours are a benchmark for connoisseurs of fine motorcars. A need for speed? We organise track days, sprints and hill climbs as well as circuit racing in venues such as Silverstone, Goodwood and Lime Rock in the USA.

Aston Martin Owners' Club

Drayton St. Leonard

Wallingford

Oxfordshire

England

OX10 7BG

+44 (0) 1865 400 400

E-Mail: hqstaff@amoc.org

Website: www.amoc.org



Produced by the Technical Publications Department
Aston Martin Lagonda Limited
Banbury Road
Gaydon
Warwick
CV35 0DB
England
Telephone:
+44 (0)1926 644300

Issue 3: October 2021
Part Number: KY9Y-19A321-AA
Barcodes conform to AML specification AMES000043

Before Driving.....	1
Controls	2
Driving.....	3
Infotainment System.....	4
Climate Control.....	5
Maintenance and Technical Data	6
Service	A
Aston Martin Warranty	B
Aston Martin Assistance.....	C
Alphabetical Index	D

Every effort has been made to make sure that the information provided in this Owner's Handbook is accurate and up-to-date. However, neither the manufacturer or the Dealer, by whom this Owner's Handbook is supplied, will in any circumstances be held responsible for any inaccuracy or the consequences thereof.

Software instructions in this handbook are correct at time of print.

However, these may be subject to change due to ongoing software updates during the vehicle's lifetime. Contact your Aston Martin Dealer for further information.

© Copyright Aston Martin Lagonda Limited, 2021. All Rights Reserved. This publication is provided with your vehicle for your personal, private and non-commercial use. No part of this publication may be reproduced, stored in a retrieval system or transmitted, in any form, electronic, mechanical, photocopying, recording or other means without prior written permission from Aston Martin Lagonda Limited.

The manufacturer reserves the right to vary specifications without notice in accordance with its policy of continual product improvement.

Before Driving

Vehicle Key	1.2
Unlocking and Opening	1.3
Checks Before Driving	1.5
Cabin Features	1.6
Camera Monitoring System	1.7
High Voltage Systems	1.11
Safety Systems	1.14
Child Safety	1.18

Vehicle Key

The vehicle is supplied with two primary keys. Keep the second key in a safe place. Do not leave a vehicle key in the vehicle when unattended.

⚠ Warning: *The engine can be started by any person in the vehicle if the brake pedal is pressed down and the start button is pressed. Care should be taken that the vehicle key is not left in the vehicle with only occupants such as young children or pets inside.*

 If a vehicle key is lost, contact your Aston Martin Dealer.

Vehicle Key Functions

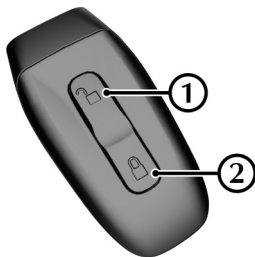

[1] UNLOCK: Press and release to unlock the vehicle.

[2] LOCK: Press and release to lock the vehicle and arm the security system.



Vehicle Key Battery

⚠ Warning: *The vehicle key contains a small cell battery. Do not ingest or swallow the battery. If the battery is swallowed, there is a risk of choking, severe internal chemical burns or death. Always keep both new and used batteries away from children and do not allow children to use the vehicle key. If you suspect a battery has been swallowed, immediately seek medical attention.*

Battery Replacement

To replace the vehicle key's battery:

1. Remove the screw (A) and lift the cover.

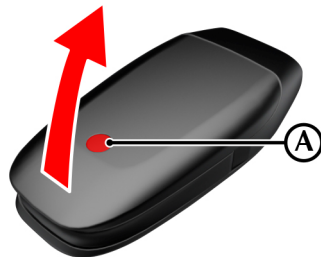

Unlocking and Opening

2. Remove the battery from the key.



3. Insert a new CR2032 battery with the positive (+) side facing up.
4. Fit the lower cover back on to the key.
5. Install and tighten the screw.

Unlocking The Vehicle

With Vehicle Key

Stand within approximately 10 m (32 ft) of the vehicle, and press



To show that the security system has been disarmed and the vehicle unlocked, the direction indicators will flash once.

With Keyless Entry

To unlock the vehicle with keyless-entry, operate the door switch with the vehicle key within 1.5 m (5 ft) of the vehicle.

Opening The Doors

To open the door, press the button (A) and lift the door.

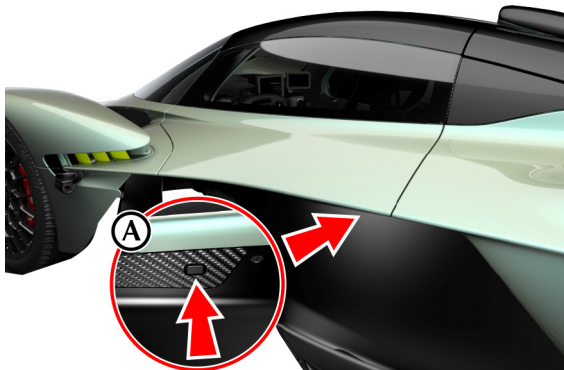

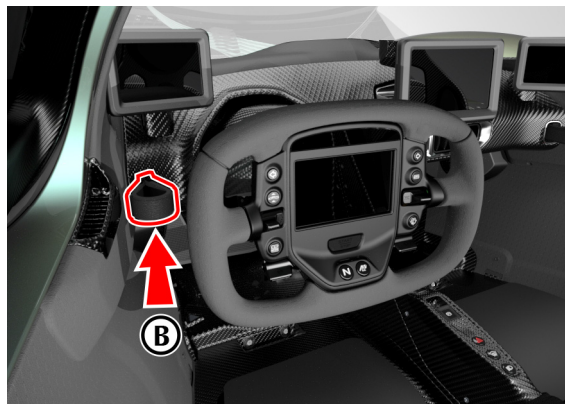

To open a door from inside, pull the release handle (B).



Checks Before Driving

Vehicle Locking

 *Keyless entry does not lock the vehicle once the key is out of range.*

To lock the vehicle, stand within 10 m (32 ft) and press  on the vehicle key. To show that the security system has been armed and the vehicle locked, the direction indicators will flash twice.

The vehicle can also be locked internally through the infotainment screen, and will also be set to lock automatically when the vehicle is driven away.

Inspect your vehicle to make sure that everything is according to the information and specifications in this Owner's Guide.

Outside the Vehicle:

- Visually check the road wheels, wheel nuts and tyres.
- Check that all windows, rear view cameras and lamps are clear and unobstructed.
- Check the operation of all lamps.

Once Inside the Vehicle:

- Check that the doors are securely closed.
- Check that all gauges and symbols are reading correctly and steering wheel is correctly adjusted.
- Check that all passengers have fastened their seat harnesses.

Cabin Features

Driving Position Adjustment

Steering Wheel

The steering wheel uses a quick release boss so that the steering wheel can be removed.

To release the steering wheel, pull on the release ring (A) and pull the wheel away from the steering column.

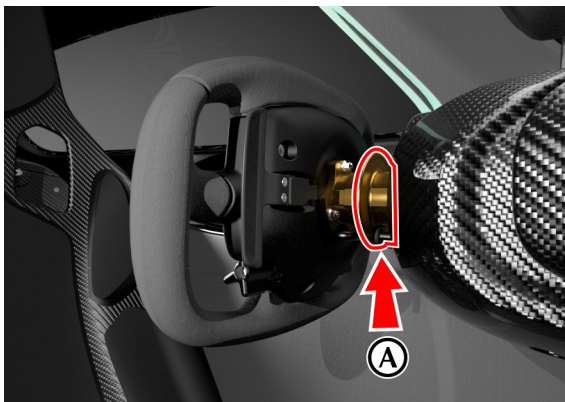

To attach the wheel, push the wheel onto the boss until it engages. If necessary, rotate the wheel until it engages with the steering column.

Steering Column

⚠ Warning: Do not adjust the steering wheel whilst driving.

The reach and tilt angle of the steering column can be manually adjusted. To unlock the steering column, pull the release lever (B) down. Pull the steering wheel backwards or forwards to adjust the reach. Lift the wheel up or down to adjust the steering angle. Raise the lock lever back into position to lock the steering column into position.

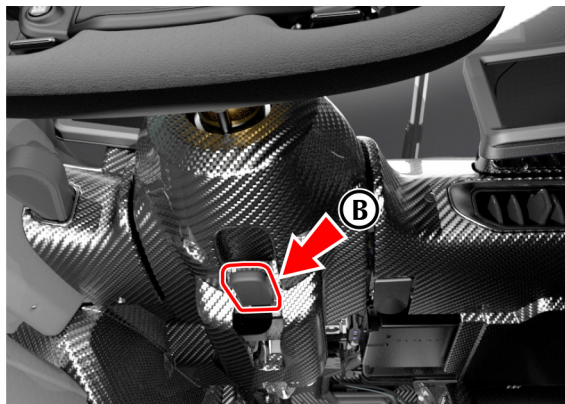

Pedal Adjustment

⚠ Warning: Do not adjust the pedals whilst driving.

To reach a comfortable driving position the pedal box can be adjusted forwards or backwards. To unlock the pedal box, pull the release lever (C) down. Once unlocked, the pedal box assembly can slide forwards or backwards. Raise the lock lever back into position to lock the pedal box into position.

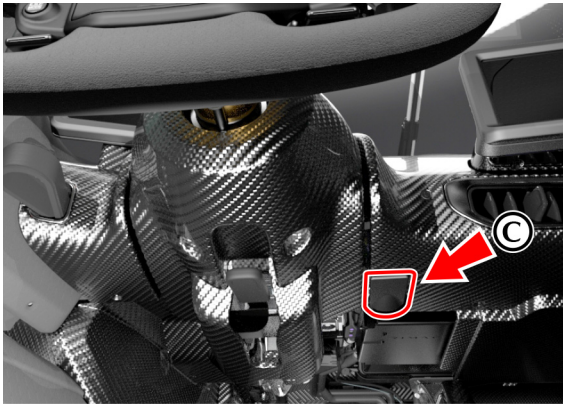

⚠ Warning: Care should be taken when the cameras see intense bright light such as direct sunlight or vehicle headlamps. This can briefly disrupt the display whilst the contrast is adjusted. It is also possible that brightness in each camera display may be different due to lighting conditions. It is the driver's responsibility for awareness of surrounding objects and vehicles.

⚠ Warning: The display mirror has a limited field of view. It is the driver's responsibility for awareness of surrounding objects and vehicles. Failure to be aware of the vehicle surrounds can cause accidents resulting in injury and death.

 Mirror display brightness is synchronised with the infotainment and instrument cluster screen brightness.

External Mirrors

⚠ Warning: *The driver must always drive in such a way that if the display contents are unclear or the camera system fails, no other road users or property will be endangered or injured. It is the driver's responsibility for awareness of surrounding objects and vehicles.*

 Unlike standard road car mirrors, the camera display system does not change perspective when the driver moves their head. There may be some initial familiarisation when the system is first used.

The mirrors for this vehicle consist of externally mounted cameras and display screens and are always on with the ignition or when a door is opened.

The screens are not adjustable but provide a wide field of view.

Heated Camera

⚠ Caution: *Do not manually attempt to remove ice from the camera lens. This can scratch or otherwise damage the camera lens and affect the quality of the display image.*

The external cameras have a built in heating element which will automatically remove any moisture and ice at low temperatures.

Decreasing Accommodation

The ability for a drivers eyes to accommodate different information between forward traffic and rearward traffic shown in the camera display system is crucial. The eyes capacity to do this can decrease over time such as on long journey's or due to age.

To reduce the effects of decreasing eye accommodation, regular breaks should be taken during long journeys. To reduce the effects of permanently decreased eye accommodation, regular eye health checks are recommended.

Interior Rear View Display

⚠ Caution: Do not spray glass cleaner or other liquid directly onto the mirror. Only use a paper towel or similar that has been dampened with glass cleaner. This will help prevent damage to the electronic components in the mirror.

The interior display mirror uses a video feed from a camera located above the engine cover to display behind the vehicle. The display mirror can also be used as a traditional mirror.

Automatic Dim

The interior display mirror will increase or decrease brightness automatically based on ambient light outside the vehicle.

Mirror Menu

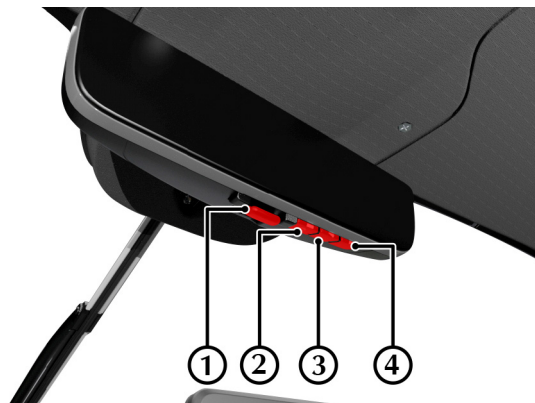

To adjust settings for the mirror use the buttons on the right side of the mirror.

[1] : Mode Switch

[2] : Menu button.

[3] : Left navigation button.

[4] : Right navigation button.

Use the mode switch (1) to change between and mirror mode and display mode. Use the mirror menu and navigation buttons to adjust brightness and vertical adjustment.

Maintenance

Cameras

If the camera lens is dirty it should be rinsed with clear water. Do not apply pressure to the lens or scratch the lens as this will directly affect the field of view or contrast of the display screen.

Displays

⚠ Caution: Do not spray glass cleaner or other liquid directly onto the mirror. This will help prevent damage to the electronic components in the mirror.

Exterior Mirror Displays: Clean using a soft cotton or chamois leather cloth. This may be dry or slightly wetted with clean water or a mixture with glass cleaner.

Interior Mirror Display: Only use a paper towel or similar that has been dampened with glass cleaner.

Fault Conditions

Mirror Reset

In the event that a mirror has a fault, such as a brightness not adjusting from a bright light source, the mirror displays can be reset by turning the vehicle ignition off and back on. If the fault persists the vehicle should not be driven. Contact your Aston Martin Dealer.

Pixel Damage

If a mirror display screen shows any missing pixels, the mirror can still be used but should be repaired as soon as possible. If larger areas of the camera display have damaged pixels to the point that larger display areas are not visible, this should be treated as a displayed warning and the vehicle should not be used. Contact your Aston Martin Dealer.

Fogged Display

If a camera display shows a foggy or blurred appearance for an extended period over 15 minutes, it is possible that the camera display may be malfunctioning. Clean the affected camera for the display. If the fault persists, contact your Aston Martin Dealer.

Centre Mirror

If there is a fault with the camera for the centre display mirror, a warning symbol will be shown in the camera display. Contact your Aston Martin Dealer.

Side Camera Display

If there is a fault with the camera or the side camera display displays, a warning message will be given in the infotainment screen and a warning symbol will be shown in the affected camera display where applicable. Contact your Aston Martin Dealer.

High Voltage Systems

This vehicle is a parallel hybrid vehicle. This means that drive is provided by both a traditional internal combustion engine and high voltage electric motor, both of which are connected directly to the transmission.

The electric motor is between the engine and gearbox and is also used as a generator, transmission gear synchronisation, reverse gear and pull away. As a high voltage system is also available, the air conditioning compressor, cabin heater are electrically operated rather than engine driven. The power steering pump is also electrically driven rather than engine driven.

E-Motor

This vehicle features an electric motor that is used to perform multiple functions on the vehicle to improve performance and reduce engine load.

Starter Motor

The electric motor itself is used as the starter motor for the engine. When the engine is first started, this will also synchronise the engine, electric motor and transmission.

Initial Pull Away

To allow for smoother pull offs, the electric motor allows the vehicle to move from a stop in first gear up to speeds of 10-15 km/h (6-10 mph) before the clutch is engaged and engine power applied.

Reverse Gear

The transmission itself does not contain a traditional physical reverse gear. Instead, first gear is selected and the electric motor is run backwards to achieve reverse.

Transmission Synchronisation

The electric motor is used to synchronise the speed of the transmission input shaft to the engine speed.

Generator

To increase engine efficiency, the engine does not have a belt driven alternator. When excess torque is generated from the engine, the electric motor is used to charge the battery.

Torque Infill

During gear changes or other areas in the torque curve where there would usually be a drop in torque, the electric motor supplies torque to compensate and provide a smoother and more consistent supply of torque.

Regenerative Engine Braking

When the throttle is lifted, a negative torque is generated to slow the engine and provide an additional braking effect. The electric motor amplifies the effect of this negative torque, increasing aggressiveness depending on the handling mode selected.

ERS Boost

(Track Mode Only)

The Energy Recovery system (ERS) boost can temporarily provide an on-demand increase of up to 100 Nm operated from the steering wheel (Refer to 'ERS Boost', page 3.18).

High Voltage (HV) Safety

⚠ Warning: Failure to follow warnings during normal use and emergency rescue procedures can cause severe or fatal burns or electric shock. Please read this manual thoroughly to fully understand the features of this vehicle and to be able to act correctly in the event of this vehicle being involved in an accident.

⚠ Warning: This vehicle is equipped with systems that make it possible to access the vehicle safely in special conditions. However, you must always assume that the high voltage system in the vehicle is live when approaching a hybrid vehicle that is damaged, has been involved in an accident or fire, or in the event of rescue or recovery.

⚠ Warning: Never assume that the vehicle ignition system is off because the engine is quiet. The high voltage system can be live without the internal combustion engine running.

⚠ Warning: Never touch cables, connectors or components of the high voltage system with bare hands as this can cause severe or fatal burns or electric shock. If you see any high voltage components that look damaged, contact your Aston Martin Dealer. Under no circumstances attempt to repair the damage.

⚠ Warning: Risk of serious burns or electric shock resulting in injuries that can be fatal. The high voltage electrical system and high voltage battery are dangerous and may cause burns, other serious injuries or death. Never attempt to remove or tamper with the high voltage cables (with orange covering), the high voltage battery, connectors or any other component in the high voltage system.

High Voltage System Activation

The High Voltage (HV) system is live and energised whenever the vehicle is in stand-by mode, such as when the vehicle doors are first opened.

HV Component Identification

⚠ Warning: Never touch, disassemble, remove or replace any high voltage (orange) cables or their connectors. There is a risk of severe burns and shock that can cause serious injury or death.

Each component in the HV system is identified by a label indicating a potential risk of electric shock.

HV cables are identified by having an orange outer layer.

Road Accident Cautions

Emergency Shut Off

When a certain level of impact is detected by the impact sensors, the emergency shut off system turns off the HV system. If the emergency shut off system is activated, the vehicle will not restart. To have the system reset, contact your Aston Martin Dealer.

HV Isolation Loop

Trained Persons Only

⚠ Warning: The HV isolation loop should never need to be used except by trained emergency persons, and is included for reference information only. Interference with the HV system by untrained persons can cause accidents that can lead to burns, injury or death.

As an additional failsafe to fully isolate the HV system in this vehicle in the event of a crash or other road traffic emergency, this vehicle is equipped with a High Voltage Isolation Loop (HVIL) (A). Should the HV system need to be deactivated and made safe, the loops can be cut in the areas marked by the labels. This will then break the HV interlock, disabling the HV system.

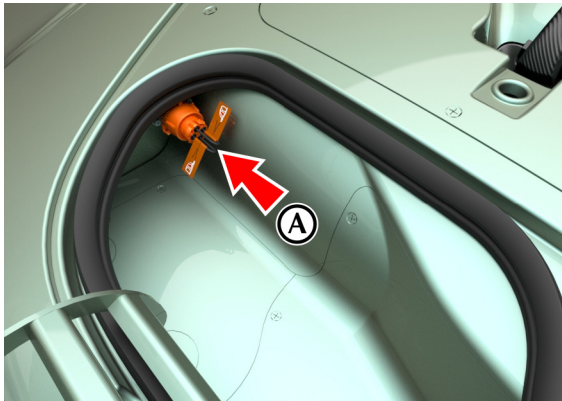

Safety Harnesses

⚠ Warning: Never use the lap portion of the belt of the harness without the shoulder belts and the anti-submarining strap.

⚠ Warning: Safety harnesses should not be worn with the straps twisted.

⚠ Warning: Never use safety harnesses to restraint persons who weighs less than 40 kg or are less than 150 cm in height, regardless of age.

⚠ Warning: Never restrain more than one person in place with each safety harness.

⚠ Warning: Always wear the lap belt portion of the harness low and tight across the pelvis.

⚠ Warning: Pressure of the shoulder straps must be equal between your shoulders and chest.

⚠ Warning: Never wear the belts over heavy clothing as it can interfere with proper positioning and adjustment of the belts, reducing the overall effectiveness of the system.

⚠ Warning: Never wear the belts over rigid or breakable objects in or on your clothing, such as eye glasses, pens, jewellery, keys etc. as these may cause injury.

⚠ Warning: Never allow straps to rub against sharp objects.

⚠ Warning: Never allow the belts to be damaged by becoming caught in door or seat hardware.

Buckle Engagement

1. Loosen the shoulder belts to allow for proper positioning of the lap belts and centre buckle.
2. Engage lap belt and tighten securely. Make sure the buckle is well centred to your body.
3. Engage the anti-sub belt in the downward pointing opening on the buckle (if it is not the fix point at the buckle).
4. Securely tighten the anti-sub belts.
5. Engage the shoulder belts into the buckle.
6. Securely tighten the shoulder belts.

Strap Adjustment

 To prevent adjuster slippage, belts should be kept in line when adjusted.

To tighten a strap, pull the strap end (A). To lengthen a strap, lift the adjuster tab (B) up and pull the belt (C).

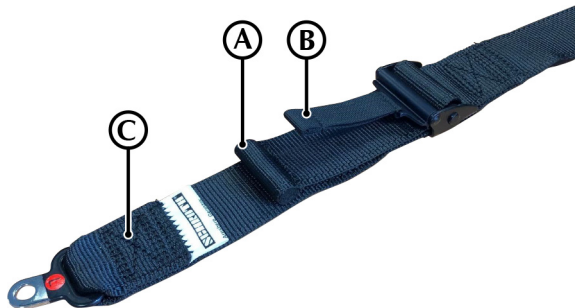

Buckle Release

1. Loosen the shoulder belts (not necessary in an emergency).
2. Press the button (D) on the centre buckle.



3. All belt latches but one will release from the buckle, either a lap belt or anti-sub belt latch will stay engaged in the buckle.

Harness Condition

⚠ Warning: Never use any belt that is cut, torn or damaged in any way. Replace it immediately, cut the old belt in half, and discard the old belt so that it cannot be used again. Cuts, tears and other damage to the belt will greatly reduce its effectiveness, may cause it to fail. Risk of severe injuries or death.

To make sure that the restraint webbings are in correct working order, regularly check the seat belt harnesses. Look for fraying, cuts, burns and similar problems. Make sure that the latches and buckles operate correctly. If a seat belt harness is not in good condition or is not working correctly, contact your Aston Martin Dealer.

Harness Replacement

⚠ Warning: Never use a harness belt that has passed 5 year from the FIA manufacturing date shown on each individual belt in the seat harness. Use of expired belts may not offer full protection in the event of an accident which can result in either serious injury or death.

Each seat harness belt has an FIA expiration of 5 years after the 1st of January from when the belts was made. Individual belts should never be used after this date (Refer to 'Harness Replacement', page 6.3).

Ear Protection

⚠ Warnings: Operating this vehicle at high engine speeds can result in high noise levels in the vehicle cabin. Exposure to high levels of noise for an extended period can lead to hearing damage. To reduce noise exposure, the vehicle is supplied with headsets that should be worn where permitted when the vehicle is driven.

To protect occupant hearing, this vehicle is supplied with a pair of aircraft grade noise-cancelling headsets which should be worn whenever the vehicle is driven. These headsets also include a built in intercom to allow the driver and passenger to talk in comfort and connect to the infotainment system for music, navigation instructions and telephone calls.

For more adjustment, care and functional information on the headsets, (Refer to 'Headsets', page 4.15).

Fire Suppression System

⚠ Warning: *The fire suppression system is only to reduce the spread of fire and allow occupants more time to safely leave the vehicle. It is not a full extinguisher system. In the event of a fire, the fire service should still be called out to assist.*

 *The fire suppression system is single use per bottle. Once the system has been used, the suppressant bottle must be refilled.*

 *The fire suppression system must be serviced every two years.*

This vehicle is fitted with a fire suppression system to combat fire in the event of a crash or malfunction. The system operates in the vehicle engine bay and cabin and is activated from within the cabin. The suppression system itself uses a colourless and odourless gas.

To activate the fire suppression system, press the suppression button (A) located in the roof of the cabin. Once pressed, occupants should leave the vehicle as soon as its safe to do so.

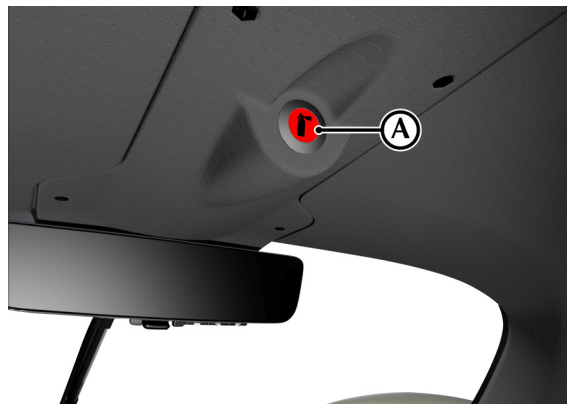

Child Safety

Aston Martin strongly recommends that a child, regardless of age, should always be restrained when travelling in a vehicle.

Your vehicle has no devices that support the installation of child restraints.

⚠ Warning: Each seat harness assembly must be used by only one passenger. It is dangerous to put a seat harness around a child being carried on the passengers lap.

Child Seats

Consult with local manufacturers of forward facing restraint and booster cushions. These manufacturers can supply you with advice on the safety of their particular child restraints and also advice on installation instructions.

Mass Group	Seating Position
As shown on the child safety seat packaging	Front Passenger
'0' Up to 10 kg	X
'0+' Up to 13 kg	X
'I' 9 to 18 kg	X
'II' 15 to 25 kg	X
'III' 22 to 36 kg	X

Table Key

U: Suitable for 'universal' category restraints approved for this mass group.

UF: Suitable for forward facing 'universal' category restraints approved for this mass group.

L: Suitable for particular child restraint systems. These restraints may be of the 'specific vehicle', 'restricted' or 'semi-universal' categories.

B: Built in restraint approved for this mass group.

X: Seat position not suitable for children in the mass group.

•: Unsuitable for use with many child restraints due to limited space.

Supplied under ECE Regulation 16.

Controls

Steering Wheel Controls.....	2.2
Instrument Display	2.3
Centre Controls.....	2.6
Lighting Controls	2.6

Steering Wheel Controls

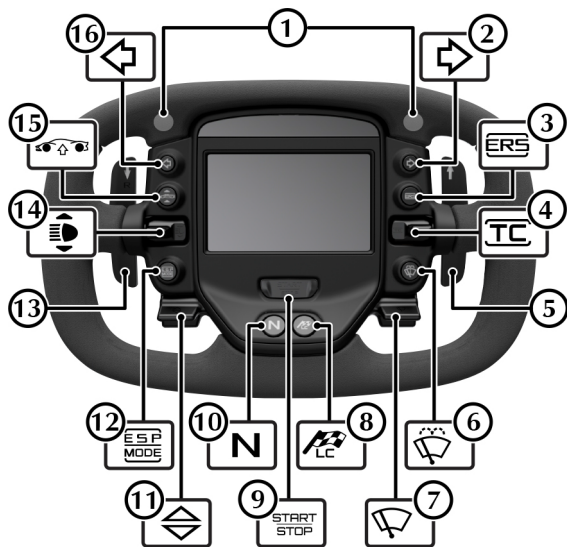

[1] HORN: Press to sound the horn.

[2] RIGHT INDICATOR: Press to activate the right direction indicator.

[3] ERS: Press and hold to briefly provide a torque boost from the electric motor¹.

[4] TRACTION CONTROL: Adjust traction control settings².

[5] UPSHIFT PADDLE: Change transmission up a gear.

[6] WINDSCREEN WASHER: Press to activate the windscreen wash and wipe.

[7] WINDSCREEN WIPER: Set the wipers to auto, slow, fast or off.

[8] LAUNCH CONTROL: Use to activate launch control.

[9] START/STOP: Press to start or stop the engine.

[10] NEUTRAL: Press to select neutral gear for the transmission.

[11] ESP / HANDLING MODE: Use to move between ESP or handling modes.

[12] ESP / HANDLING SELECT: Select which mode is changed by switch [11].

[13] DOWNSHIFT PADDLE: Change transmission down a gear. Also used to select reverse when in neutral.

[14] DIPPED/MAIN BEAM LAMP SWITCH: Use to switch between full and dipped beam and flash main beam.

[15] BODY LIFT MODE: Raises the body to give additional clearance over speed bumps and gradients³.

[16] LEFT INDICATOR: Press to activate the left direction indicator.

¹ Handling set to Track mode only and under heavy throttle.

² ESP set to Track mode or Off only.

³ Available at speeds up to 15 km/h (9 mph).

Instrument Display

Instrument Cluster Gauge Overview

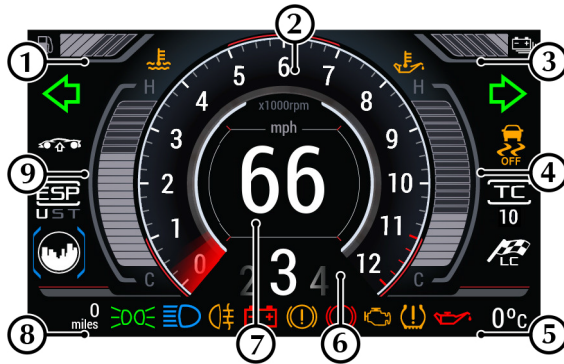

[1] FUEL GAUGE:

Shows how much fuel is left in the fuel tank.

The fuel symbol will also change to amber, then red, the lower the fuel level is.

[2] TACHOMETER:

Shows the engine speed in revolutions per minute x 1000.

[3] BATTERY STATE OF CHARGE:

Shows the state of charge for the HV battery system.

The battery symbol will also change from amber to red as the charge is reduced.

[4] ENGINE OIL TEMPERATURE GAUGE:

Shows the engine oil temperature.

[5] OUTSIDE TEMPERATURE:

Shows the outside temperature.

[6] GEAR INDICATOR:

Shows the current selected gear.

[7] SPEEDOMETER:

Central gauge that displays vehicle speed.

[8] ODOMETER:

Shows total distance travelled by the vehicle.

[9] ENGINE COOLANT TEMPERATURE GAUGE:

Shows the engine coolant temperature.

Warning and Status Symbols

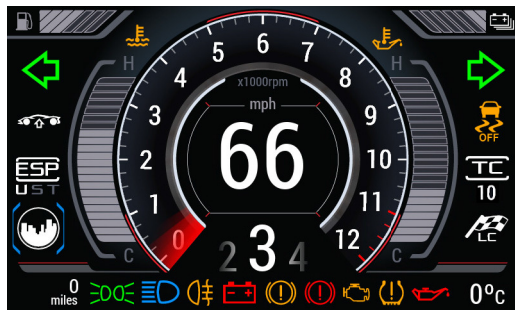

[1] INDICATOR LAMPS:

Shows when left or right direction indicator is active. Both directions will operate if the hazard lamps are active.

[2] BODY LIFT:

Shows if body lift mode is active and flashes whilst body is raised or lowered.

[3] ESP STATUS:

Shows if the ESP is to set to U (Urban), S (Sport), T (Track) or Off.

[4] HANDLING MODE:

Shows if handling mode is in Urban, Sport or Track mode.

[5] SIDELAMPS:

Shows the vehicle's side and dipped beam lamps are on.

[6] MAIN BEAM HEADLAMPS:

Shows if the vehicle's main beam headlamps are on.

[7] REAR FOG LAMP:

Shows if the rear fog lamp is on or off.

[8] BATTERY WARNING:

The electrical system will do a self-test when the ignition is first turned on. If the warning stays on, or illuminates during driving, there may be a fault with the battery or electrical power system.

[9] BRAKE WARNING:

If either symbol stays on, there may be a fault with the braking system.

[10] MALFUNCTION INDICATION LAMP:

Steady amber shows a fault in the engine management system. Continue driving only if there are no audible, visible or physical signs of degraded engine performance. Consult your Aston Martin Dealer as soon as possible.

Flashing amber shows a major fault in the engine management system. Stop immediately. Contact your Aston Martin Dealer.

[11] OIL PRESSURE WARNING:

Shows if oil pressure is below safe limits. Stop immediately to reduce the risk of engine damage.



[12] TYRE PRESSURE:

If this symbol stays on or comes on while driving, a tyre or tyres' air pressure is below specification

**[13] LAUNCH CONTROL:**

Shows when the launch control is ready to be used.

**[14] TRACTION CONTROL:**

Shows the selected traction control setting.¹

**[15] ELECTRONIC STABILITY PROGRAM (ESP):**

Shows if the Stability control is on or off. During normal operation the ESP symbol will flash when intervening



If, while ESP is on, the ESP symbol stays on or it comes on whilst driving, the ESP system has detected a fault. Consult your Aston Martin Dealer as soon as possible

[16] COOLANT WARNING:

- **Yellow Temperature Warning**

If the yellow coolant temperature warning symbol is shown, the vehicle will go into the first stage of power management (Refer to 'Vehicle Power Management', page 3.2) as the coolant temperature has exceeded its peak operating temperature. Available torque and rpm will be slightly reduced as part of this power management. For more information (Refer to 'High Speed Driving Cool Down', page 3.3).

- **Red Temperature Warning**

If red temperature warning symbol is shown, the engine coolant is at critical temperature, and both torque and rpm will be heavily restricted. The vehicle must be driven at a low rpm in a high gear and with smooth throttle application to reduce the engine coolant temperature or bring the vehicle to a controlled stop and turn off the engine.

[17] OIL TEMPERATURE WARNING:

Shows if oil temperature level is too high

¹. Adjustable in ESP Track mode or Off only.

Centre Controls

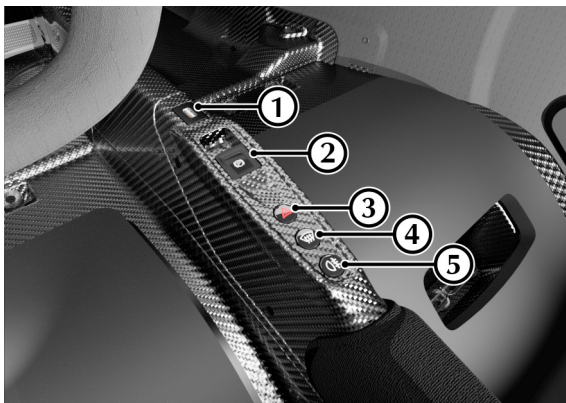

[1] USB PORT: Provides a USB connection port for the infotainment system.

[2] ELECTRIC PARK BRAKE (EPB): Use to release or apply the park brake

[3] HAZARD WARNING SWITCH: Press to set the hazard warning lamps to on or off.

[4] SCREEN DEMIST: Press to use the screen demist function and switch the heated front screen on.

[5] FOG LAMP: Press to set the rear fog lamp to on or off.

Lighting Controls

Exterior Lamps

Exterior lamps are controlled from the infotainment screen. Touch the symbol to select the lamp setting.

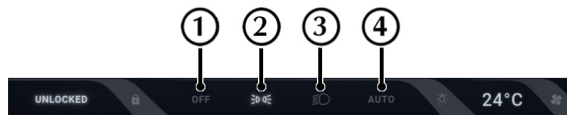

[1] : Lamps off₁

[2] : Side lamps (including number plate lamps)

[3] : Dipped beam headlamps

[4] : Automatic headlamp mode

Rear foglamp₂

Exterior lamps (except the side lamps/parking lamps) switch off automatically if you turn the ignition off.

 *The lamps will default to Auto whenever the vehicle is unlocked.*

1. A window will be shown where the driver must confirm the lamps are to be set to off.

2. The rear fog lamp will only operate with the headlamps set dipped beam (3) or automatic (4).

Automatic Headlamp Mode

If ambient light fades, headlamps, rear and registration plate lamps will switch on automatically. If ambient light then increases, headlamps, rear and registration plate lamps will automatically go off. Automatic lamps are market specific.

 The automatic headlamp function features an internal timer that starts when the lamps are turned on. This prevents the lamps from rapidly changing between on and off if situations where ambient light can rapidly change, such as driving between buildings. The headlamps may show a small delay between when a suitable amount of ambient light is detected, and the lamps turning off.

Steering Wheel Lamp Controls



Main Beam

Push the lamp switch (1) up to turn the main beams on. Push the switch up again to return to dipped beam headlamps.

Flash Headlamps

Push the lamp switch down to flash the main beam headlamps.

Direction Indicators

To briefly indicate a change of direction, press the relevant direction indicator button (2). The indicator will flash 3 times. To latch the indicator to stay on press and hold the required indicator button. To cancel indication press the indicator button again or the indicator will cancel on completion of a manoeuvre.

Hazard lamps

 The hazard warning lamps will continue to operate if the ignition is switched off.

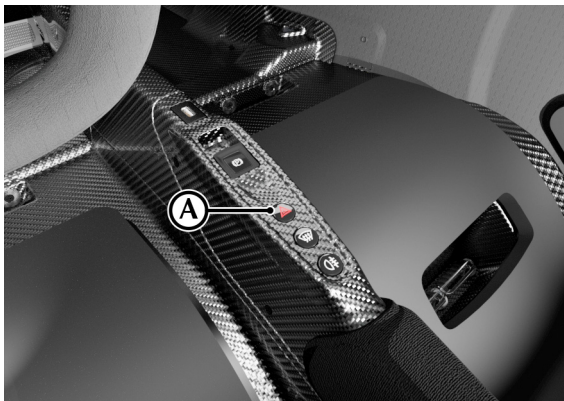

Press the hazard warning lamp button (A) to set the hazard warning lamps to on. All direction indicator signals will flash. Press the button again to set the hazard warning lamps off.

If you operate a direction indicator from the steering wheel, only the selected direction indicators will operate. Once cancelled, the hazard warning lamps will resume operation.



ASTON MARTIN

Driving

Driving Information	3.2
How To Start The Engine.....	3.5
Transmission Controls.....	3.7
Handling Modes.....	3.8
Electronic Stability Program (ESP).....	3.9
Brakes	3.13
Driving Functions	3.18
Tyre Pressure Monitoring System (TPMS)	3.20

Driving Information

Procedures for driving this vehicle may be unfamiliar to many new owners. To make sure that you have a safe and enjoyable entry into this new phase of Aston Martin motoring, please take time to safely acquire the necessary new driving skills. Practice in safe, lower speed conditions before investigating the high performance potential of the vehicle.

Driving behaviour, such as avoiding aggressive driving, travelling at lower speeds, correctly inflating tyres, reducing periods of idling and not carrying excessive weight, will improve fuel consumption and reduce CO2 emissions.

Running-In

This vehicle is fully hot tested during manufacture and no special running-in procedures are necessary. Nevertheless it is recommended to limit engine loads (e.g. by accelerating gently and by using lower gears on steep hills or when negotiating tight turns) during the first 1500 km/900 miles.

Vehicle Idling

To protect the drive train components, static idling of the vehicle should be limited to 30 minutes or less.

Vehicle Power Management

Due to the bespoke nature of the powertrain installed in this vehicle, the optimal operating window of the engine is narrower than a traditional power unit and as such care must be taken both in warming up the vehicle and in cooldown. To manage this, the vehicle is equipped with a power management strategy which limits both the rpm and the maximum torque available to the driver. This strategy is employed both at low and high engine coolant and oil temperatures and is part of the normal operation of the powertrain system.

Performance Driving Courses

Performance driving courses are available to enable you to fully understand the control functions of your vehicle and also the basic principles of performance driving. Contact your Aston Martin Dealer for further information.

Track Days

⚠ Caution: *The rear license plate should be removed before this vehicle is used on track to prevent damage from high exhaust temperatures.*

Before using this vehicle on track days contact your Aston Martin Dealer for vehicle set up, service parts and recommendations.

High Speed Driving Cool Down

When the vehicle is used on track or in sustained high speed situations, such as de-restricted sections of the Autobahn, the vehicle should perform a period of cool down running at a minimum of half speed in as high a gear as possible to allow critical components the opportunity to cool before the vehicle is brought to a stop. If driving in this manner and the engine coolant warning light is illuminated, time should be allowed to cool the vehicle until the light is no longer illuminated. Consideration should be given to the traffic scenario, fuel level, and any other factors which may affect this cool down period.

Wet Conditions

When driving in wet conditions, water can build up under your tyres so that they ride on a layer of water. This is called aquaplaning or hydroplaning. When this happens, you have little or no control. Aquaplaning is more prone to happening at higher road speeds if there is a lot of water on the road and particularly if the tyres are also under inflated or approaching minimum tread depth.

It is important to take bends or curves at a safe, reasonable speed, particularly when driving on wet or slippery road surfaces.

Slow down when it is raining.

Driving Through Deep Water

If in any doubt whether to drive through deep water, always take the side of caution to avoid potentially costly damage to the vehicle's engine or other essential systems.

⚠ Caution: *Never drive in water deeper than the lower edge of the front wing in Urban handling mode. Always proceed with extreme caution, especially when the depth is not known. Aston Martin recommend that if wading is unavoidable, that bodylift mode is used.*

When driving through water, traction or brake capability may be limited. Once through the water, always dry the brakes by driving slowly while applying light pressure on the brake pedal.

Tyre Skip At Low Speed

In certain conditions, the front tyres may 'skip' at low speeds with summer tyres installed when a high level of steering lock is applied. This is a characteristic of the vehicle and does not affect the safety or performance of the vehicle.

Starting in Cold Conditions

This vehicle will not start if the temperature in the battery cell or the engine oil is below 1°C (33°F). If the driver attempts to start the vehicle below 1°C (33°F) then a warning will be shown stating that starting the vehicle is not possible at this temperature.

Brakes in Cold Weather

At low temperatures (below 0°C / 32°F) moisture within the brake pads may freeze and cause the brake pads to stick to the brake discs. Additional torque may need to be applied when the vehicle is first used after extended periods of being parked, and there may be a noise as the brake pads become free. Once released, the brakes will operate as normal.

Drainage Holes

Beneath the centre of the vehicle and each fender are several drainage holes. As a result, small puddles of water may form underneath the vehicle after it has been stopped for a period of time. This is normal and does not show a system leak or malfunction.

How To Start The Engine

⚠ Warning: *The engine can be started by any person in the vehicle if the brake pedal is pressed down. Care should be taken that the vehicle is not left unattended with the key present and occupants such as young children inside.*



⚠ Caution: *Make sure the park brake is applied. This will prevent the vehicle from moving once the engine has started.*

To start the engine, fully press the brake pedal down and press **START/STOP** (A). Keep the brake pedal pressed down until the engine has started.

Stopping The Engine

⚠ Caution: *When the engine is stopped, the vehicle will lower to sport ride height (Refer to 'Sport', page 3.8). Be aware of kerbs, speed bumps or uneven ground before the engine is switched off.*

Press **START/STOP** to stop the engine.

Low Temperature Crank Inhibit

To protect the hybrid drivetrain, this vehicle will be unable to start if either the temperature in the battery cells or the engine oil is below 1°C (33°F). The State of Charge (SoC) gauge in the steering wheel will display as empty regardless of actual SoC and a red warning will be shown in the infotainment system.

To clear the warning and allow the vehicle to start, both the internal battery temperature and the engine oil must increase above 1°C (33°F) and the ignition turned off and back on.

Ultra Urban Mode

⚠ Caution: *As the engine and clutch are not fully engaged, the high voltage battery will not be charged at the same rate as normal vehicle modes. As such, Ultra Urban mode should be used sparingly and not as a regular driving mode.*

 Battery State of Charge shown on the instrument cluster must be at least 50% before starting the vehicle in Ultra Urban mode.

 Whilst in Ultra Urban mode, you will not be able to select handling modes. The vehicle must come to a halt and exit Ultra Urban mode, indicated by N (neutral) being shown in the gear selection indicator in the instrument cluster.

Ultra Urban mode is a specialist vehicle mode that is selected when the vehicle is first started. In Ultra Urban mode, the clutch will be open and the engine will not be engaged with the drive of the vehicle. The engine will only be running at idle speed to operate the hydraulic system for the gearbox and suspension. The electric motor provides propulsion for speeds of up to 100 km/h (62 mph), but this use comes at the cost of accelerated battery drain.

To select Ultra Urban mode:

- The engine must be off.
- Press both the N (neutral) button on the steering wheel and pull the downshift paddle at the same time.
- 'Ultra Urban Mode selected' will be shown on the infotainment screen.
- Start the engine with the **START/STOP** button.
- To select a forward gear, pull the upshift paddle. This will then select 6th gear.

Ultra Urban Mode will automatically cancel if the vehicle comes to a stop. To show that the vehicle is no longer in Ultra Urban mode, N (neutral) will be shown in the gear selection indication in the instrument cluster.

Transmission Controls



[1] : Downshift Paddle

[2] : Upshift Paddle

[3] : Neutral Button

[4] : Shift Lights

Forward Gears

Use the paddles (1) and (2) to select gears. Each pull of a paddle will move the transmission up or down one gear at a time. Selected gears will be shown in the steering wheel display.

Neutral Gear

⚠ Warning: Extreme care must be taken when neutral is selected when the vehicle is in motion. Once neutral is selected, you will not be able to select a gear again until the vehicle is stationary. Not being able to select a gear on main roads can cause an obstruction to other traffic which can cause an accident resulting in injury or death.

To select neutral, use the N button (3) on the steering wheel. If neutral is selected you will not be able to select a gear with the paddles until the vehicle is stationary. A gear must be selected whilst stationary to enable the engine, E-motor and transmission to be fully synchronised.

Reverse Gear

To select reverse gear, press the brake pedal and pull the downshift paddle whilst the vehicle is stationary and in neutral gear.

Gear Shift Indicator

(Sport and Track handling mode only)

The shift lamps (4) light up as engine speed increases to show a visual aid for optimal gear changes. As engine speed builds, the shift lights will light from left to right. When engine speed approaches a shift point the shift lights will then change colour and flash.

Handling Modes

Vehicle driving characteristics, such as suspension damping and gear changes can be changed by selecting different handling modes. Use the mode button (A) to select Mode and use the switch (B) to change between the three drive modes.



Urban

 Urban mode provides a default comfort setting, best suited to casual driving. The vehicle is set to use a base transmission calibration with slower and softer shifts, lighter steering and the suspension will be at its softest setting. The diffuser flaps will remain open to reduce downforce and improve cooling, and the engine will provide a limited level of engine braking. To remove distraction during normal driving the shift lamps will be disabled

Sport

 Sport mode provides a more focussed drive aimed towards the enthusiastic driver. The transmission uses faster and harsher gear shifts, and there is an increased weighting to the steering. The shift lamps will also now be active on the steering wheel to show optimal gearshifts. The suspension has a stiffer level of damping and ride height will lower by 16 mm. The diffuser flaps will now be dynamic for maximum downforce and there will be a greater level of engine braking.

Whilst handling is in Sport mode, ESP is set to Sport (S).

Track



Track mode increases settings for a track environment sacrificing comfort for performance. The transmission uses the fastest and harshest gear shifts, and the steering weight is further increased. The suspension will also provide the stiffest level of damping with ride height the same height used in sport mode. The diffuser flaps will again be dynamic and there will be the highest level of engine braking.

Whilst in Track mode, TC is adjustable with ESP Off (Refer to 'Traction Control System (TCS)', page 3.12) with access to the Urban (U), Sport (S), Track (T) and Off ESP modes. The ERS function is available to provide an increase in available torque (Refer to 'ERS Boost', page 3.18).

Track Mode with Track Front Clamshell

⚠ Warning: The optional front track clam is not homologated for road use. Never use this vehicle on the public highway with the track clam installed.

(Optional)

With the optional track front clamshell installed, this unlocks the ride height to be dropped by 55 mm on the front and 64 mm at the rear relative to Urban mode. ESP, active aero, suspension and steering will now use an unique track calibration for optimum performance. TPMS will also be calibrated to suit higher tyre pressures.

⚠ Warning: It is the driver's responsibility to drive safely according to the law and with due regard to prevailing conditions.

⚠ Warning: Electronic Stability Program (ESP) must never let the driver be tempted into taking risks which could affect his or her safety or that of other road users. ESP cannot overcome consequences of applying too much engine power for prevailing conditions.

ESP is designed to improve driving safety when the tyres are at the limits of their grip capabilities. This is done by control of engine torque and application of the brakes at individual wheels.

⚠ Caution: If repair or replacement of the steering or other surrounding equipment is necessary, always refer to your Aston Martin Dealer. There is a sensor in the steering system which detects steering angle. If the centre position of the steering deviates, the ESP may not operate correctly.

⚠ Caution: ESP may not operate correctly when using snow socks.



⚠ Caution: Use tyres of the same manufacturer, brand, type, tread pattern and correct size specified in this handbook for this vehicle on all four road wheels. Do not mix new and worn tyres on the same axle.

ESP Modes

ESP has four modes of operation: Urban, Sport, Track and Off. To set Urban, Sport and Track, use the mode button (A) to select ESP and use the switch (B) to change between modes.



Urban

 ESP defaults to on each time the vehicle is started. Whilst in Urban, yaw control is limited and ABS is tuned to give a level of vehicle performance, control and stability under braking that will cover everyday driving situations and weather. Traction Control (TC) is not adjustable and set as full intervention. In the event a wheel loses grip and the traction control system intervenes, the  symbol will flash in the instrument cluster.

Sport

 In Sport, yaw control and ABS is more relaxed to allow the more driver control before intervention. Whilst in Sport, Traction Control (TC) is not adjustable and set as full intervention.

Track

⚠ Warning: Track mode is intended for use on a dry track. Greater driver input will be required to maintain vehicle stability.



Track mode further reduces the level of yaw control and the ABS is tuned to allow more experienced drivers to drive closer to the limits of the vehicle's ability and enjoy its natural balance in a track environment. Traction Control TC is now adjustable between 1 (minimum) and 10 (maximum)

Whilst in Track mode, the  symbol will be continually shown in the instrument cluster.

Off

⚠ Warning: ESP Off is intended for use on a dry track. Greater driver input will be required to maintain vehicle stability.



Press and hold the selector switch to set ESP to Off. With ESP set to Off, yaw control is disabled and ABS uses a track dedicated calibration.

In Urban and Sport Modes, TC remains set to 10 and whilst in Track handling mode, TC is user adjustable. The  symbol will be continually shown in the instrument cluster.

Dynamic Wheel Torque by Brake (DWT-B)

Dynamic Wheel Torque by Brake (DWT-B) uses input signals such as speed, acceleration and steering angle to monitor vehicle behaviour during cornering. A small amount of brake pressure will then be applied to the inside rear wheel to reduce understeer. DWT-B is always active, but is more responsive when the ESP is set to either Track or Off.

Traction Control System (TCS)

The Traction Control System (TCS) is used to prevent excessive wheel spin at standing starts, or during acceleration. Wheel spin is usually caused by excessive use of the accelerator pedal, or slippery, loose or bumpy road surfaces. When ESP is set to Urban and Sport modes, this is set to full intervention. When the ESP is set to Track or Off¹, the level of intervention is adjustable to allow the driver to set the TCS to when they would like it to intervene.

⚠ Warning: It is always the drivers responsibility to drive safely according to the law and with due regard to prevailing conditions.

⚠ Warning: Traction control cannot overcome the consequences of applying too much engine power for conditions, and must never let the driver be tempted into taking risks which could affect their safety or that of other road users.

To prevent wheel spin and maintain vehicle stability in such situations, the traction control system will:

- Brake either of the driven wheels when they start to slip.
- Adapt the engine and/or E-motor torque to a level corresponding to the traction available on the road surface.

 *These symptoms are normal and will clear as wheel spin is eliminated and normal engine power is restored.*

If traction control operates when driving on extended icy or slippery surfaces, reduce engine power as necessary until the ESP warning symbol goes off.

¹. Whilst in Track handling mode

Brakes

Footbrake

⚠ Warning: *In the event of a brake failure, bring the vehicle to a stop as soon as it is safe to do so. Do not continue to drive the vehicle. To do so could result in an accident or collision resulting in death or serious injury.*

⚠ Warning: *Greater care may be necessary after a long drive over salted or gritted roads or if driving in heavy rain, through water or a vehicle wash. Brake action may be delayed and increased braking pressure may be required.*

⚠ Warning: *Aston Martin recommend that the brake fluid is replaced before and after the vehicle is used for high performance driving such as a track day. Failure to do so may result in greatly reduced brake performance.*

⚠ Warning: *Track day use and high speed driving: For track use or high speed driving new brake pads must be subject to specific conditioning. Failure to correctly condition the pads may result in greatly reduced brake performance.*

 *The high performance brake system used on this vehicle is designed to provide optimal braking under all operating conditions. However, an inherent characteristic of this braking system is some brake noise. Certain combinations of speed, braking forces and ambient conditions may also cause the brakes to squeal.*

 *The brakes in this vehicle are not servo assisted, and may have a different brake feel when first driven.*

The footbrake uses a dual (diagonal split) circuit hydraulic system with Anti-lock Brake System (ABS).

The carbon ceramic brake systems combine low weight with high performance, offering:

- Reduced unsprung weight (mass of components not supported by the suspension) to improve vehicle handling,
- Improved rate of wear characteristics,
- Improved braking performance.

 *The rate of wear of the brake pads and discs will depend on driving style and usage conditions. Track day usage will increase the rate of wear of discs and pads.*

Brake Throttle Override

If the throttle and brake pedals are both pressed at the same time, the engine will restrict available torque. Normal functionality will return when the throttle pedal is pressed without the brake pedal or the brake pedal is released.

Anti-lock Braking System (ABS)

Safety

It is always the driver's responsibility to drive safely with regard to driving conditions and according to the law. The fact that a vehicle is equipped with ABS must never let the driver be tempted into taking risks which could affect his or her safety or that of other road users.

The addition of ABS cannot overcome the consequences of trying to stop in too short a distance, cornering at too high a speed, or aquaplaning (where the tyres are prevented from contacting the road surface by a layer of water).

The driver should always take road conditions into account. A slippery road surface always requires more braking distance for a given speed, even with ABS. Stopping distances can increase with ABS compared to locked wheels on slushy snow, gravel, sand or certain heavily corrugated or ridged warning sections of road surfaces.

If any braking system malfunctions, have the braking and ABS systems checked immediately by an Aston Martin Dealer.



The Anti-lock Braking System (ABS) helps prevent the road wheels from locking and causing the vehicle to skid during emergency braking. This also assists the driver in maintaining steering and directional stability.

If the braking force exceeds tyre grip in an emergency braking situation, the ABS operates to prevent the wheels locking. A pulsating effect is felt through the brake pedal when this happens. This is a normal effect of the ABS operating.

ABS can have different levels of intervention depending on the ESP mode the vehicle is in (Refer to 'ESP Modes', page 3.10).

Brake Warnings

⚠ Warning: If either brake warning symbol comes on, you should immediately be prepared for increased stopping distances or partial failure of the braking system.



If the brake warning symbol  or  comes on while driving, the brake system has a fault and braking performance may be affected.

 A message will also show in the infotainment screen with further information.

Stop as soon as possible in a safe and convenient place. Apply the footbrake and make sure that the park brake is fully released. If the warning symbol stays on, do not drive the vehicle. It is essential that the brake system is checked immediately. Contact the nearest Aston Martin Dealer.

ABS and Electronic Stability Program (ESP) Warnings

⚠ Warning: If the ABS and ESP warning symbols come on, you should be aware that wheels could lock during extreme braking or when braking on slippery surfaces. Steering performance can also function differently and there is increased risk of skidding and/or accident.

If  and  come on while driving both ABS and ESP have a fault. The brake system will continue to operate, but without assistance from either ABS or ESP. Both front and rear wheels may lock under heavy braking which can result in longer braking distances in an emergency stop.

 A message will also show in the infotainment screen with further information.

Drive on carefully and have the braking and ABS systems checked immediately by an Aston Martin Dealer.

Brake Pad Conditioning

⚠ Warning: For track use or high speed driving, new brake pads must be correctly conditioned. Failure to correctly condition the pads may result in greatly reduced brake performance. Contact your Aston Martin Dealer for further information.

When new brake pads are installed the brake discs and pads need to be conditioned. During this time, brake performance will be reduced.

Avoid excessive braking, such as hard stops from high speed and steep descents, for the first few hundred miles or kilometres¹ after new brake pads are installed.

Park Brake

Park Brake Operation

⚠ Warning: If the brake system warning symbol is on or flashing, do not rely on the park brake to hold the vehicle stationary. Contact your Aston Martin Dealer.

When the vehicle is stationary, push and hold the park brake switch (A) in until the park brake releases. The  warning symbol in the instrument cluster will come on when the park brake is applied. If the park brake is applied whilst the vehicle is moving, the stop lamps will come on.

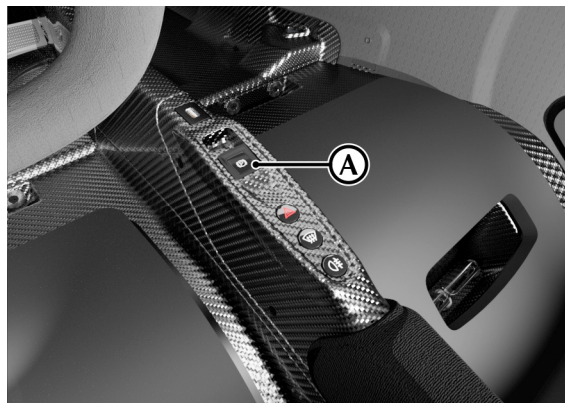

¹. Distances can vary depending on driving conditions and frequency of brake use

 The park brake operates on the rear wheels of the vehicle.

! Caution: Secure parking of the vehicle is dependent on being on a hard and stable surface. The rear wheels must be on a suitable surface to prevent vehicle movement.

The ignition must on to release the park brake. First apply pressure to the foot brake then pull on the park brake switch and release. The  symbol will go off to show the park brake has been released.

Park Brake Operation While Moving

 Warning: Repeated use of the park brake to slow the vehicle, or driving the vehicle with the park brake applied can cause serious damage to the brake system.

In an emergency, push and hold the park brake switch to reduce speed. The  symbol will come on and a warning sound will be heard.



Release the switch to cancel the park brake application whilst the vehicle is moving. The park brake will only apply as normal once the vehicle has stopped movement.

Park Brake Emergency Operation

If the switch for the park brake fails, there is a secondary method of release. When the brake pedal is pressed whilst a gear is selected, the park brake will then release. While in this emergency mode the park brake will automatically apply each time the vehicle is stationary and the transmission is in neutral (N) for more than 1 second.

Driving Functions

ERS Boost

 ERS boost is only available in Track  handling mode

The Energy Recovery system (ERS) boost can temporarily provide an on-demand increase of up to 100 Nm. To activate this boost press and hold the ERS button (A) on the steering wheel with heavy throttle application.



Launch Control

Launch control optimises elements of the high voltage system to accelerate the vehicle as fast as possible from a standing start.

When a launch is performed, the E-motor will output maximum power on pull away and the gearshifts will be as quick as possible, and will continue to provide an ERS boost throughout the launch.



Activation

To activate launch control:

1. Press the launch control button (A) with a forward gear selected.



2. The vehicle will enter charging mode, shown by the launch control icon  flashing white in the steering wheel display.

3. Stop the vehicle (if the vehicle is not already stationary) and fully press the brake pedal.
4. When charging is complete the launch control icon  will be shown in solid white.
5. Once charged, fully press the accelerator pedal whilst keeping the brake pedal pressed. The launch control icon  will now turn green. To launch the vehicle, release the brake pedal.

 *Once launch control is active, there will be no rise in engine speed as initial launch is completed by the e-motor. Power from the engine is applied once the vehicle is in motion.*

Cancellation

Before a Launch: Launch control will be cancelled if the brake is released or the throttle is pressed before the system is charged

(launch control icon  is solid white). The system will also be cancelled if Neutral (N) or Reverse (R) gears are selected.

After a Launch: Launch control can be cancelled after a launch by:

- Pressing the brake pedal.
- Releasing the throttle pedal.
- Changing gear (if this would cause engine speed to drop below rpm threshold).
- Selecting neutral gear.
- Pressing the launch control button.

Tyre Pressure Monitoring System (TPMS)

⚠ Warning: Driving on a significantly under-inflated tyre causes the tyre to overheat and can lead to tyre failure. Over-inflation and under-inflation also reduces fuel efficiency and tyre tread life, and may affect the vehicle's handling and stopping ability.

⚠ Warning: The TPMS is not a substitute for correct tyre maintenance, and it is the driver's responsibility to maintain correct tyre pressures, even if under-inflation has not reached the level to set the TPMS tyre pressure indicator symbol to on.

A Tyre Pressure Monitoring System (TPMS) is installed as a safety feature. This system will display the tyre pressures for each tyre and provide warnings if pressure is below a specified pressure for each tyre.

Each tyre should be checked at least once every two weeks when cold, and inflated to the pressure recommended by the vehicle manufacturer or on the tyre pressure label. If your vehicle has tyres of a different size than the size indicated on the tyre pressure label, you should determine the proper tyre pressure for those tyres.

For recommended tyre pressures for this vehicle (Refer to 'Wheel and Tyre Information', page 6.15)

Tyre Pressure Display

The TPMS display can be shown in the infotainment screen and can be found in the **Vehicle** menu. The screen itself shows the pressure in each tyre as well as a temperature display. If a tyre is below the minimum pressure this will be shown in red as well as the  symbol being illuminated in the steering wheel display.

 Tyre pressures can also be seen in the drop down quick access menu.

 Tyre pressures will be displayed in the infotainment display after the vehicle has been driven for a few minutes.

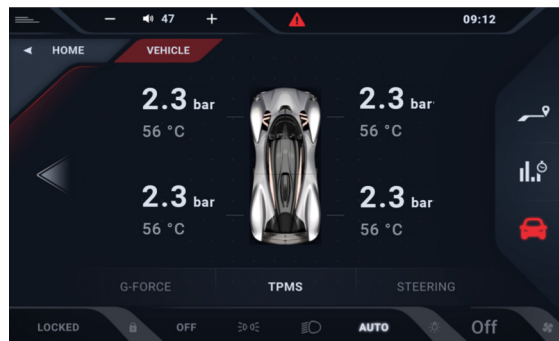

 Warning: When a tyre pressure warning is detected, reduce the vehicle speed to a safe level. Stop in a safe and convenient place and inspect the tyre(s).

 The tyre pressures may be displayed in the wrong positions for a short time if the wheels have been moved on the vehicle. After a few minutes of driving, the TPMS will calibrate and the tyre pressures are displayed in the correct positions.

TPMS with Track Clamshell

When the Track Clamshell is installed, TPMS calibration will be switched to match the higher pressures required for sustained high speed driving.

TPMS Malfunction Warning

If the TPMS malfunctions due to a system failure or tyre transmitter fault,  will **flash for approximately 75 seconds and then remain lit.**

 A malfunction of the tyre pressure monitor can take up to ten minutes to be shown. The TPMS warning lamp will go out when the fault has been resolved and after several minutes of driving.

A TPMS malfunction can be caused by:

- A defective TPMS sensor.
- Wheels and tyres installed that do not have TPMS sensors.
- Unapproved item interfering with the TPMS.
- TPMS system or software fault.

If the system shows there is a TPMS fault, continue at a reduced speed of 30mph / 48 km/h maximum. Contact your Aston Martin Dealer.



ASTON MARTIN

Infotainment System

Infotainment Main Menu.....	4.2
Bluetooth	4.3
Multimedia	4.5
Navigation System	4.9
Phone System.....	4.11
Vehicle Menu.....	4.13
Settings Menu	4.14
Headsets	4.15

Infotainment Main Menu

The main infotainment menu screen is used to navigate to most of the vehicles controls.



[1] QUICK ACCESS MENU: Tap to open a quick access menu and support information for icons show in **[3]**.

[2] VOLUME: Shows audio volume level. Press + or - to increase or decrease the volume.

[3] PRIMARY STATUS ICONS: Shows warnings and notification icons for vehicle errors, TPMS, brightness and valet mode. Music and bluetooth status will also be shown if these systems are switched on. The time will also be shown. Further information for each icon is given in the vehicle status menu

[4] MAIN MENU SCREEN: Main menu to select infotainment functions.

[5] VEHICLE LOCK STATUS: Shows lock or unlock status of vehicle doors. Press to change states between lock and unlock.

[6] EXTERIOR LAMP STATUS: Shows the lamp settings/ the select setting will be highlighted. Press to choose a lamp setting.

[7] CLIMATE SETTING: Shows climate control temperature setting. Press to open climate menu.

Quick Access Menu

A quick access menu is available to have a summarised view of several infotainment function and show any warnings with the vehicle. From the quick access menu you will be able to scroll through the below items:

- Vehicle errors.
- Connected phone or Bluetooth device (if connected).
- Music (if player is open).
- Tyre pressures.
- Screen and mirror display brightness adjustment.
- Valet mode.

Bluetooth

Bluetooth®¹ technology is a standard for short-range wireless data transmissions up to approximately 10 metres. Bluetooth can be used to connect your mobile device to the vehicle infotainment system. This system can then be used to operate the hands-free phone system and for Bluetooth audio streaming.

Pairing a Device

 *Bluetooth must be activate on the mobile device.*

Before a device can be used, it must be paired to the infotainment system. To add a new device from the infotainment system, select Bluetooth in the Settings menu and select the device you wish to connect from the list of Available devices. Previously paired devices will be shown under Paired devices.

Follow the instructions shown on the device and the infotainment display to pair the device.

¹ The Bluetooth® word mark and logos are registered trademarks owned by Bluetooth SIG, Inc., and any use of such marks by Aston Martin is under license. Other trademarks and trade names are those of their respective owners.

Device Management

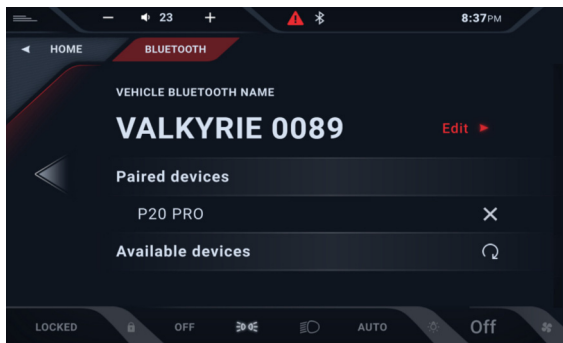

Vehicle Bluetooth Name

Select Edit to change the Bluetooth name shown for your vehicle.

Connected Devices

Shows the device that is currently connected to the infotainment system.

Paired Devices

Shows devices that have previously been paired and connected to the infotainment system.

Available Devices

Shows devices that are available to pair to the infotainment system.

Multimedia

Source Selection

To select a media source swipe from the right of the screen. Select from:

- Internet radio
- Phone (Bluetooth)
- My Media (Hard disk)
- USB (If connected)

Internet Radio

Station List

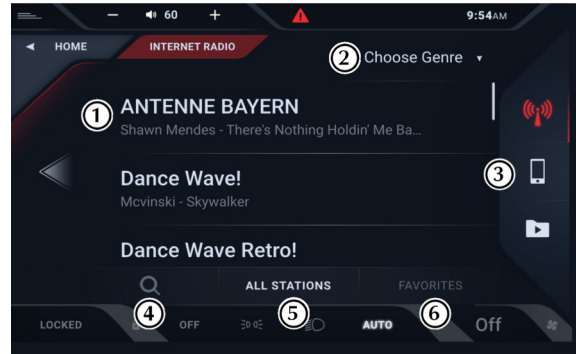

- [1] STATION LIST:** Shows a scrollable list of available stations.
- [2] GENRE FILTER:** Select to apply a genre filter to the station list.
- [3] SOURCE PANEL:** Shows media source options.
- [4] SEARCH:** Search for station by search term.
- [5] ALL STATIONS:** Show full list of available stations.
- [6] FAVORITES:** Shows the list of saved favorite stations. Stations saved as favorites will be shown in the station list with a star symbol.

Playing Screen

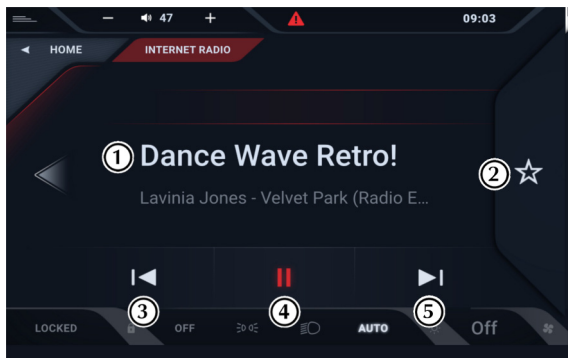

[1] TRACK INFORMATION: Shows Selected radio station, artist and track name (where available).

[2] FAVORITE: Press to add to favorites.

[3] PREVIOUS STATION: Press to change to the previous station in the station list.

[4] PLAY/PAUSE: Press to play or pause the track.

[5] NEXT STATION: Press to change to the next station in the station list.

Favorites

To save a station to favourites, press and hold a station in the station list or press  on the playing screen.

To remove a station from the favorites list, press and hold the station in the favorite list and press .

Phone Media

Playing Screen

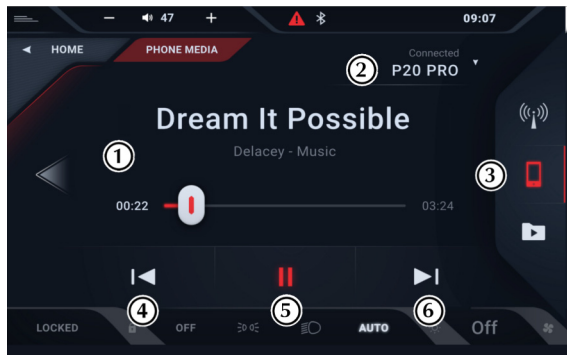

[1] TRACK INFORMATION: Shows track name, artist and album name.

[2] DEVICE LIST: Open to select the device to be used as an audio source.

[3] SOURCE PANEL: Shows media source options.

[4] PREVIOUS: Press to skip back to the start of the track. Press at the start of the track to play the previous track. Press and hold to rewind the track.

[5] PLAY/PAUSE: Press to play or pause the track.

[6] NEXT: Press to play the next track. Press and hold to fast forward through the track.

My Media

Folder Search

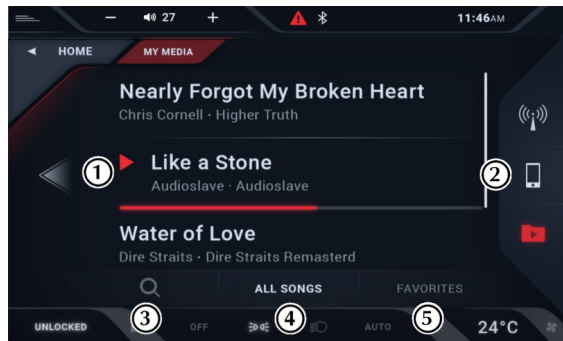

[1] TRACK LIST: Shows track names, artist and album name. If there is already playing this will be shown along with a track progress bar.

[2] SOURCE PANEL: Shows media source options.

[3] SEARCH: Search for track by search term.

[4] ALL SONGS: Show full list of available songs.

[5] FAVORITES: Shows the list of saved favorite songs. Songs saved as favorites will be shown in the track list with a star symbol.

Playing Screen

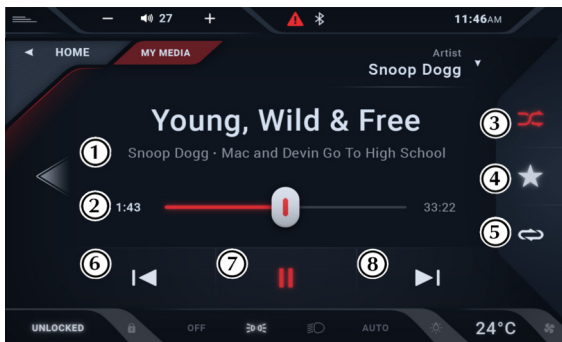

[1] TRACK LIST: Shows track names, artist and album name. If there is already playing this will be shown along with a track progress bar.

[2] TRACK PROGRESS: Shows track length, progress and time elapsed.

[3] SHUFFLE: Play tracks in a random order.

[4] FAVORITE (HARD DISC ONLY): Add current track favorite.

[5] REPEAT: Press to cycle between no repeat, repeat track or repeat all in a given album or playlist.

[6] PREVIOUS: Press to skip back to the start of the track. Press at the start of the track to play the previous track. Press and hold to rewind the track.

[7] PLAY/PAUSE: Press to play or pause the track.

[8] NEXT: Press to play the next track. Press and hold to fast forward through the track.

USB Transfer

Audio files can be transferred from a USB media source and saved to the infotainment hard disk. To transfer tracks, press and hold the track(s) in the track list whilst the source media is set to USB or press select all to upload all tracks in that folder. Press



to begin uploading the file(s).

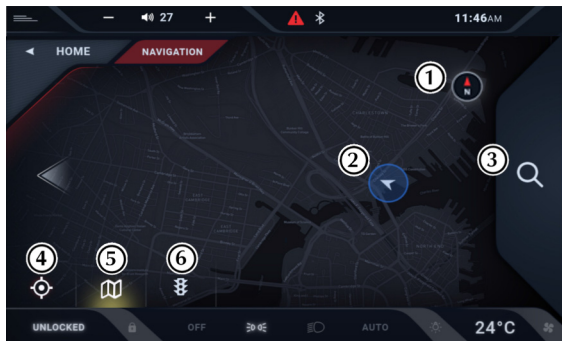

[1] **COMPASS:** Shows direction of north on the map.

[2] **LOCATION:** Current location and direction of travel.

[3] **SEARCH ADDRESS:** Press to open the address entry page.

[4] **CENTRE LOCATION:** Centre the map on current vehicle location.

[5] **MAP TYPE:** Changes map time between satellite and street view.

[6] **TRAFFIC:** Overlay traffic information onto the map.

Map Navigation

To navigate within the map, swipe to pan across the map. To zoom in, pinch two fingers together and to zoom out, expand two fingers.

Address Entry

Use the search button to open the address entry page. In the search bar search for an address by entering the street name, a post code or the name of a point of interest to plot a route to. Once a destination has been set the total travel time, distance and estimate time of arrival (ETA) will be given. To begin route navigation, press  route guidance.

Route Guidance

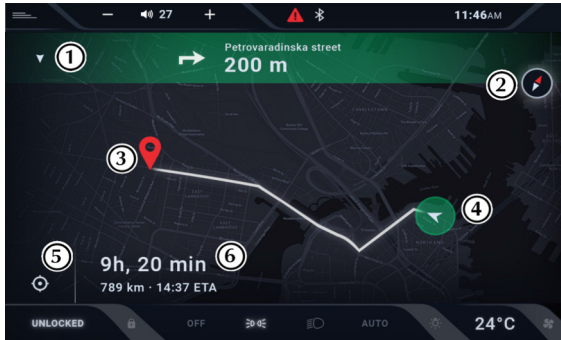

- [1] **NEXT TURN:** Shows information for the next turn. Tap to open the list of directions for the route.
- [2] **COMPASS:** Shows direction of north on the map.
- [3] **DESTINATION:** Shows destination on the map as a location.
- [4] **LOCATION:** Current location and direction of travel.
- [5] **CENTRE LOCATION:** Re-centre location back to vehicle.
- [6] **ROUTE INFORMATION:** Shows route time to completion, distance and estimated time of arrival.

Navigation Settings

- Map Mode
 - Night Mode
 - Day Mode
 - Auto Light Sensor
- Voice Navigation
- Routing options
 - Shortest Distance
 - Fastest route
- Route Configurations
 - Tolls
 - Ferries
 - Highways

Phone System

A bluetooth mobile device must first be connected. If a device is not connected you will be prompted to connect a bluetooth device.

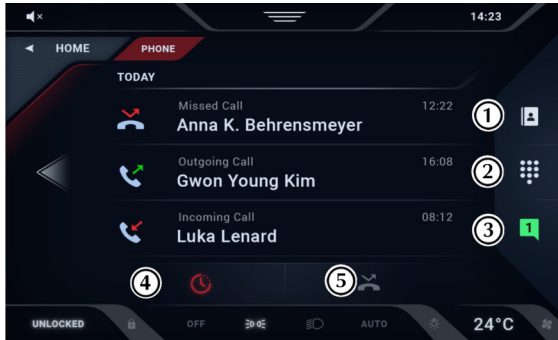

[1] CONTACT LIST:

Opens the phones contact list.

[2] DIAL PAD:

Opens a number pad to manually dial a phone number.

[3] MESSAGES:

Opens message menu. The number shows number of unread messages.

[4] CALL HISTORY:

Select to show the recent call history in the main window.

[5] MISSED CALLS:

Select to show the recent call history in the main window.

Calls

Make a Call

A call can be made in several ways:

- Choose a contact from the contacts list.
- Enter a number using the on screen number pad and press



- Select a contact from the call history/missed call window.

To End a Call

To end a call, press the  button.

To Answer a Call

To answer an incoming call, press .

To Reject a Call

To reject a call, press the . You can also reject a call with a preset text message.

Messages

 *The connected mobile phone must support Message Access Profile (MAP) to be able to access text and email messages. This may have to be confirmed separately for some devices when paired to the vehicle.*

Messages will be shown by sender in the message window. Select a conversation to open the message history with that contact. Conversations with unread messages will be highlighted, and the total number of unread messages will be shown in the  icon.

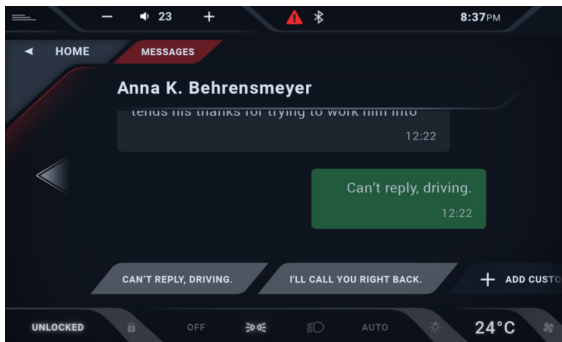

In the message conversation window you can see the previous conversation history. At the bottom of the screen are a number of preset text responses, and the option to create custom text responses.

If 'Add Custom Response' is selected, a text entry window will be opened where a custom message can be used to for future responses to messages and rejected phone calls.

Vehicle Menu

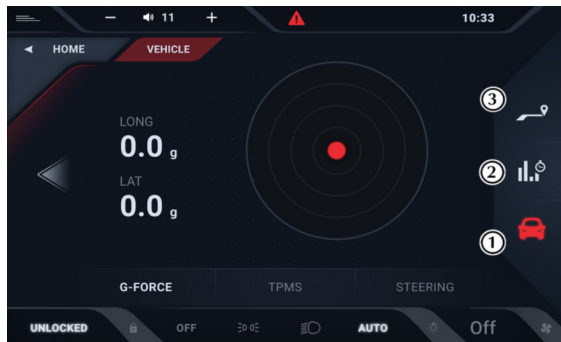

[1] VEHICLE DATA: Shows a live vehicle data screen. Select from:

- G-Force
Shows G-forces exerted on the vehicle as both longitudinal and lateral g's
- TPMS
Shows individual tyre pressure values. Can also be set to show individual tyre temperatures.
- Steering
Shows steering angle with a top down model. Bar graphs showing both brake and throttle application are also shown.

[2] GRAPH DISPLAY: Shows various parameters for the vehicle in a graph format:

- Vehicle Speed
- Engine Speed
- Torque Usage (combined)
- Gear
- Ambient Temperature
- Barometric Pressure
- Engine Oil Temperature
- Engine Coolant Temperature
- Engine Oil Pressure (low pressure)
- Engine Oil Pressure (high pressure)
- HV Battery State of Charge
- 12 Battery State of Charge
- 12 Battery Voltage
- HV Battery Current
- HV battery Voltage
- Altitude

[3] VEHICLE RANGE: Show a list of range related parameters

Settings Menu

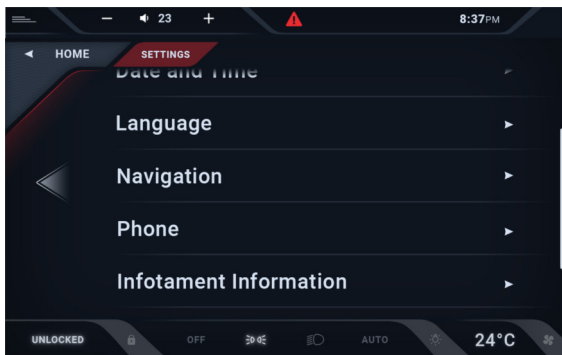

[1] BLUETOOTH: Shows a list of connected and available devices and options (Refer to 'Bluetooth', page 4.3).

[2] SCREEN BRIGHTNESS: Adjust brightness level for the screen and side mirror displays.

[3] SUSPENSION SWEEP: Select to begin a cycle of the suspension hydraulic system (Refer to 'Suspension Sweep', page 6.6)

[4] AUDIO SETUP: Adjust bass, treble levels and audio balance.

[5] MEASUREMENT UNITS: Select what units measurements are given in.

[6] DATE AND TIME: Adjust date and time settings.

[7] LANGUAGE: Select system language.

[8] NAVIGATION: Opens the navigation options menu.

[9] PHONE: Set up to three custom fixed text response messages.

[10] INFOTAINMENT INFORMATION: Displays software levels, available hard disk space and copyright information.

[11] VEHICLE INFORMATION: Display Vehicle Identification Number (VIN), odometer and when the next service is due.

[12] VALET MODE: Opens the valet menu.

[13] SYSTEM RESET: Select whether to restore to factory settings, only erase personal data such as Bluetooth and navigation information, or restore to factory settings and delete and media content saved to the infotainment system.

Headsets

⚠ Warnings: Operating this vehicle at high engine speeds will create high volume levels in the vehicle cabin which can damage hearing. The supplied headsets should be worn when the vehicle is driven.

This vehicle is supplied with a pair of aircraft grade noise-cancelling headsets which should be worn whenever the vehicle is driven. The headsets include a built in intercom to allow the driver and passenger to talk in comfort and connect to the infotainment system for music, navigation instructions and telephone calls.

Connection

To connect the headsets to the vehicle, plug the connector from the headset(s) into the fly leads found by the inner shoulders of the seats. Once connected the headsets will be powered whenever the infotainment system is on.

Adjustment

For the headsets to correctly provide hearing protection, the headsets must be adjusted correctly. The headset should be worn so that the head pad lightly touches the top of the head. The vertical sliding assembly can then be adjusted to fit. The memory foam on the ear pads will then shape to provide a seal around the ears.

To adjust the microphone, move the boom up and down or in and out by rotating and flexing the boom as necessary. The ideal position for the microphones is approximately 3mm (1/8") from the lips

Intercom and Infotainment

The headsets are permanently set to work as an intercom between the driver and the passenger when the vehicle infotainment is on. The infotainment also sends audio such as the radio, music and phone, through to the headsets.

Care and Maintenance

To remove the ear pads, gently pull off the headset. To install, carefully stretch over the lip of the earpiece.

To remove the head pad, gently pull off from the headpiece of the headset. To install, align the head pad with the head band and push on to attach.



ASTON MARTIN

Climate Control

Climate Controls	5.2
Defrost and Demist	5.4
Climate Control Operating Tips	5.5

Climate Controls

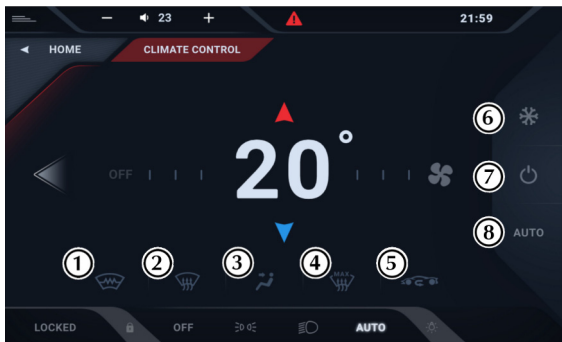

To adjust the temperature swipe up or down on the display and left or right to adjust the fan speed.

[1] HEATED FRONT SCREEN: Set the heated front screen to on or off. If max demist is used, this will be turned on automatically.



The heated front screen will turn off automatically after 6 minutes.

[2] SCREEN AIRFLOW: Directs air flow on to the front windscreen.



[3] OCCUPANT AIRFLOW: Directs air flow at the occupants.



[4] MAX DEMIST: Press for maximum demist. Outside air intake is automatically selected and air conditioning is automatically started.



[5] RECIRCULATION: Sets the climate system to use recirculated air rather than air from an outside source.



[6] AC ON/OFF: Turns the air conditioning on or off.



[7] CLIMATE CONTROL ON/OFF: Turns the climate control system on or off.



[8] AUTO: Sets and maintains the temperature at a set level in automatic mode.



Climate System Operation

 *The air conditioning compressor and heater will only be available whilst the engine is running.*

 *Powertrain systems such as the high voltage battery, inverter, dc-dc converter and e-motor use the same air conditioning system as the cabin. To make sure the vehicle operates as intended, these systems will take priority over cabin cooling. If any of these systems become too hot, cabin cooling will be decreased to make sure these critical powertrain components can be sufficiently cooled.*

The climate control system for this vehicle uses a compressor driven by the high voltage electrical system and a Positive Temperature Coefficient (PTC) heater to provide cabin heating, replacing the need for a traditional circulated coolant system.

Automatic Climate Control

The temperature is maintained at a set level in automatic mode. The climate system will automatically control the temperature, airflow and the air distribution according to the interior and exterior conditions.

To set a temperature for automatic operation:

- Set a temperature.
- Press 
- The LED indicator lamp will switch on.

 *Any changes to the air distribution or airflow speed will cancel automatic climate control.*

Defrost and Demist

Manual Climate Control

Manually set the temperature, airflow speed and air distribution:

⚠ Warning: Re-circulated air can cause the interior glass to mist up in cold or rainy weather. If demisting is required, use the air conditioning.

 The climate system will produce the selected temperature regardless of in-vehicle conditions.

For an increased cooling effect, press  to use re-circulated air.

 If the centre console switch is pressed, this will also activate the heated front screen.

Press  on the infotainment screen, or the demist button (A) on the centre console.

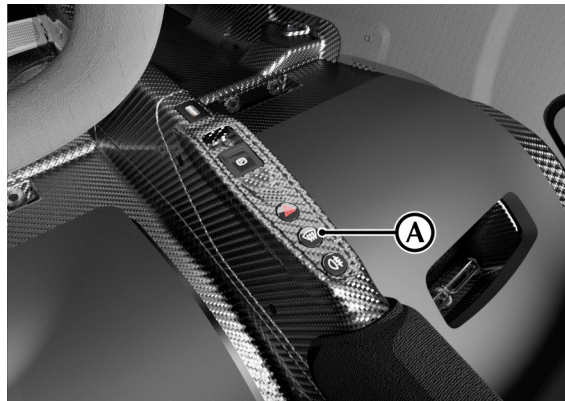

The outside air intake is automatically selected, the temperature is set to maximum and air conditioning is started.

To cancel automatic defrost or demist either:

- Press  again.
- Select a different airflow mode.

 The automatic defrost setting times out after 6 minutes.

Climate Control Operating Tips

- Moisture which forms on the evaporator in the air conditioning unit is discharged via a drain tube onto the road. After stopping, small puddles of water may form underneath the vehicle. This is normal and does not show a system malfunction.
- Set the climate system to off when in a car wash or if the vehicle is being pressure washed.
- Windows can fog up easily in humid weather. Use the climate control system to demist the windows.
- Clear all obstructions like leaves, snow and ice from the bonnet and the air inlet below the windscreen to improve the system efficiency.
- Use the 'outside air' position in normal conditions. The 're-circulated air' position should be used temporarily when driving on dusty roads or for quick cooling or heating of the interior.
- Operate the climate control system at least once a month to keep internal parts lubricated.
- Have the climate control system checked before the weather gets hot. If the climate control system is low on refrigerant or has a malfunction, consult your Aston Martin Dealer.
- Mist may come out from the vents when using the air conditioning. This is humid air being suddenly cooled and not a sign of a malfunction.



ASTON MARTIN



ASTON MARTIN

Maintenance and Technical Data

Introduction	6.2
Servicing Precautions.....	6.3
Owner Maintenance Checks	6.5
Engine Cover Release	6.7
Fluid Checks and Capacities	6.8
Chassis Systems	6.13
Wheels and Tyres.....	6.15
Electrical Systems	6.18
Vehicle Care	6.26
Powertrain Specifications.....	6.31
Performance	6.32
Dimensions	6.32
Emergency and Breakdown	6.34
Fuel.....	6.43

Introduction

Due to the sophistication of the various systems and the specialised equipment required to maintain this vehicle, owner maintenance should be restricted to the routine procedures described in this chapter.

If you think that this vehicle is not functioning correctly, please contact an Aston Martin Dealer for the vehicle to be professionally checked.

Parts and Lubricants

Aston Martin recommends that when performing a servicing task, the recommended lubricants and parts are used.

! Caution: *If oils or lubricants are used which do not meet the required fluid specification, vehicle components may experience excessive wear, a build-up of sludge and deposits or cause increased pollution. If it is evident to Aston Martin that use of products other than those which are recommended by the manufacturer have caused damage to the vehicle or engine, Aston Martin may refuse to authorise the repair of such damage under the terms of the manufacturer's warranty.*

Electronic Fuel Injection

! Warning: *If the fuel system is allowed to run dry, the fuel pump(s) can be permanently damaged.*

! Warning: *Any modifications or additions to the fuel system not specifically designed by Aston Martin are prohibited. If installed, they can cause damage to the fuel system which, in some circumstances, could cause fire. All Service Action and Safety Recall Actions must be undertaken by an Aston Martin Dealer.*

The electronic fuel injection system requires specialist equipment and test facilities to set up and maintain so that the vehicle gives maximum performance, coupled with economy, reliability and safe vehicle emissions. You are, therefore, strongly advised to entrust all service work to an Aston Martin Dealer.

Harness Replacement

Each seat harness belt has an FIA expiration of 5 years after the 1st of January from when the belts were made. Individual belts should never be used after this date.

Both shoulder straps in each harness have an elastic alignment strap to make sure that when the belts are adjusted, the belts are kept in line to reduce the risk of belt slippage. This must be replaced annually.

For more information on the replacement of seat harness belts, contact your Aston Martin Dealer.

To avoid personal injury, the following safety precautions must be observed when the engine cover is open and the engine is operating or the ignition is on.

⚠ Warning: Protect yourself against dangerous substances.

⚠ Warning: Keep hands, hair, tools, items of clothing and jewellery clear of all drive belts, pulleys and operating mechanisms. The cooling fan may operate even though the engine is not operating.

⚠ Warning: Avoid skin contact with all exhaust system and engine components, engine fluids and escaping steam. They may be hot and can cause scalding or burns.

⚠ Warning: Any loose objects, such as ties, should be removed before working on a vehicle. Any jewellery should also be removed before working on a vehicle, especially work on the electrical system.

⚠ Warning: Catalytic converters convert harmful exhaust gasses into less noxious substances and so reduce environmental pollution. They operate at high temperatures and continue to radiate a considerable amount of heat after the ignition has been set to off.

⚠ Warning: Do not work beneath the vehicle with a vehicle lifting jack as the only support. Place suitable stands under the vehicle.

⚠ Warning: Do not breathe exhaust fumes. Exhaust fumes contain carbon monoxide. Carbon monoxide is a dangerous gas, which is colourless and odourless and can cause unconsciousness and may be fatal. Never start or leave the engine running in an enclosed, unventilated area.

⚠ Warning: Keep children and pets clear of the vehicle. Do not let anyone inside the vehicle unless specifically working to your instructions.

⚠ Warning: Whenever possible, work in the engine compartment with the engine cool, the ignition off and the vehicle battery disconnected.

⚠ Warning: Petrol is highly flammable and, in confined spaces, is also explosive and toxic. In the event of spillage, set the engine to off. Do not use a flame or spark near fuel or fuel vapour. Do not smoke near fuel or fuel vapour. Do not inhale fuel vapour or fumes.

⚠ Warning: Before any work is started on this vehicle's high voltage system, the high voltage disconnect in the front storage compartment must be removed and the battery made safe. If you do not there is risk of severe burns injury and death.

For more information on high voltage safety (Refer to 'High Voltage (HV) Safety', page 1.12)

Dangerous Substances

⚠ Warning: Dangerous substances should be kept out of reach of children.

⚠ Warning: Many liquids and other substances used in motor vehicles are poisonous and should under no circumstances be consumed and should, so far as possible, be kept from contact with the skin. These substances include battery electrolyte, antifreeze, oil, brake and clutch fluid, petrol, windscreen washer additives, lubricants, refrigerant and various adhesives.

⚠ Warning: Particular care should be taken to avoid unnecessary contact with used engine oil. Always read carefully the instructions printed on labels or stamped on components and follow them carefully. Such instructions are included for reasons of your health and personal safety. Never disregard them.

Engine Oils

⚠ Warning: *Prolonged and repeated contact with used engine oils can cause serious skin disorders, including dermatitis and cancer. Avoid excessive contact, wash thoroughly after contact. Keep out of reach of children. When your oil is changed, be sure that it is done by an experienced person. In addition, observe all laws regarding the disposal of waste oil and toxic fluids.*

Protect The Environment

⚠ Warning: *It is illegal to pollute drains, water courses, or soil. Use authorised waste disposal facilities, including civic amenity sites and garages providing facilities for receipt of used oil. If in doubt, contact your local authority for advice.*

In the interests of safety and reliability, it is advisable to carry out the following checks at the intervals suggested (more frequently if your vehicle is heavily used or operating in adverse conditions), and always before starting on a long journey. Refer to the following pages for advice and check procedures.

Before Use Check:

- Operation of lamps, horn, indicators, wipers, washers and warning symbols
- Check there is sufficient fuel for the intended journey, particularly at night and before entering motorways
- Operation of the seat belts
- Operation of the brakes
- Check for fluid deposits underneath the vehicle.

Weekly Checks

(daily if driving large distances or touring)

- HV battery state of charge
- Tyre condition
- Engine coolant level
- ERS coolant level
- Battery coolant level
- Brake fluid level
- Air conditioning operation
- Windscreen washer fluid level
- Check operation of windscreen washers.

Monthly Checks

- Active suspension cycle

Fuel Filler Bowl

During fuel filling check that the fuel filler bowl drain pipe is free from debris which may block the pipe. If the pipe is blocked, water can not drain from the bowl and can overflow into the fuel tank.

Engine Oil Level

⚠ Caution: *It is important to check the engine oil level regularly. Running the engine with engine oil below the lower mark or above the upper mark can cause serious engine damage.*

Check the engine oil level every fourth fuel tank fill or weekly - whichever ever is the sooner.

Suspension Sweep

⚠ Caution: *Activating the suspension sweep function will perform a complete sweep of all the ride height actuators on this vehicle which will cause the ride height of the vehicle to fluctuate. Before a suspension sweep is initialised, make sure that there are no objects beneath the vehicle, as this can damage the vehicle as the suspension is cycled.*

If the vehicle is not regularly used, the system must be cycled monthly for the active suspension systems to operate in the best condition. To perform a suspension sweep, the vehicle must be started, and the Suspension Sweep function initiated in the Settings menu in the infotainment system (Refer to 'Settings Menu', page 4.14). This will cycle the suspension actuators to lubricate the seals and prevent them from drying out.

For a suspension sweep to be started, the below conditions must be met.

- Hydraulic supply must be available.
- The vehicle must be stationary.
- The transmission must be in N (neutral).

If any of the above conditions change or the suspension sweep is turned off manually, the suspension sweep function will be deactivated.

Whilst the suspension system cycles, this allows for the HV battery to be charged to prevent it from draining over time. If charging the battery as well, the vehicle should be run for a minimum of 15 minutes.

Engine Cover Release

High Voltage Checks

Battery State of Charge (SoC)

 To help maintain the battery SoC, the supplied battery conditioner should be connected whenever the vehicle is not in use.

The HV battery SoC should be checked on a weekly basis. To check the battery SoC, select vehicle in the infotainment screen for a graphical display or it will also be shown in the instrument cluster menu.

If the SoC is below 20% then the vehicle should be started so that the battery is charged to at least 80%.

To open the engine cover, pull the lever located in the left side door aperture.

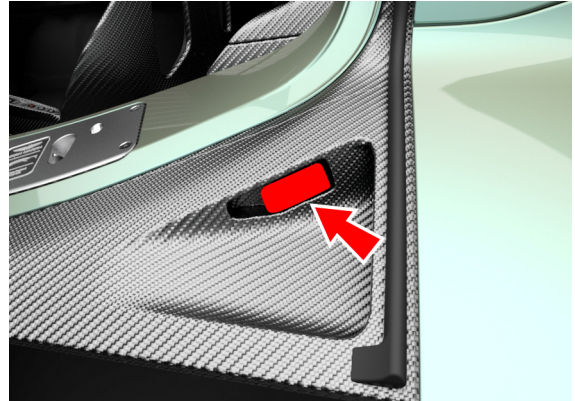

Slightly lift the rear edge of the engine cover to lift it. The engine cover is held open by a carbon rod.

Fluid Checks and Capacities

Front Fluid Reservoirs

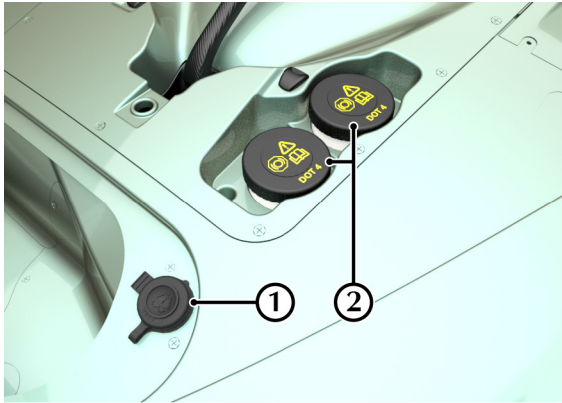

[1] : Windscreen washer fluid reservoir

[2] : Brake reservoirs

Engine Bay Fluid Reservoirs

⚠ Warning: Engine components may be hot and could cause severe burns.

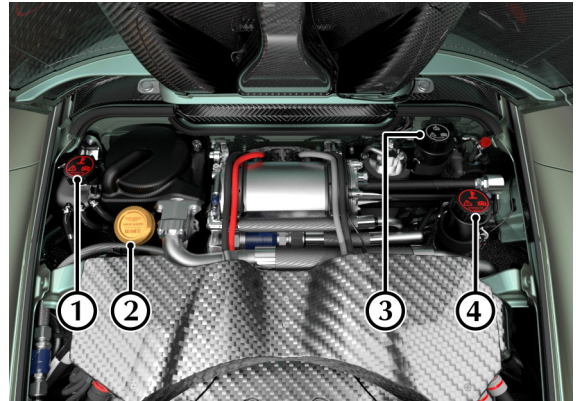

[1] : Engine coolant reservoir.

[2] : Engine oil filler cap and dip stick.

[3] : Battery coolant reservoir.

[4] : ERS coolant reservoir.

Engine Oil Level

⚠ Warning: Engine oil or components may be hot and could cause severe burns.

⚠ Caution: Running the engine with engine oil below the lower mark or above the upper mark can cause serious engine damage.

⚠ Caution: This vehicle's warranty may be invalidated if damage is caused by the use of incorrect engine oil. Low quality or obsolete oils do NOT give the protection required by modern, high performance engines.

⚠ Caution: Failure to use engine oil that meets the required specification can cause excessive engine wear, a build up of sludge and deposits, and increased pollution. It could also lead to engine failure.

⚠ Caution: Care must be taken when oil is checked or added. If oil drips onto any of the engine hoses, this can cause them to swell and become damaged over time.

Engine Oil Level Check

1. Make sure the vehicle is on level ground.
2. Run the engine until the oil temperature is 75°C or higher. Engine oil temperature can be checked in the infotainment system (Refer to 'Vehicle Menu', page 4.13).
3. Once the oil temperature is at least 75°C, increase the engine speed to 3000 rpm and hold for 30 seconds.
4. Turn the engine off.

 For the oil level check process, the oil temperature must be between 75°C and 85°C

5. Between 10 and 20 seconds after the engine is turned off, unscrew the oil filler cap. Withdraw and wipe the dipstick with a clean lint free cloth.
6. Fully insert the dipstick into the oil tank, and withdraw the dipstick again.
7. The engine oil level should read between the Min. (A) and Max. (B) indentation marks.

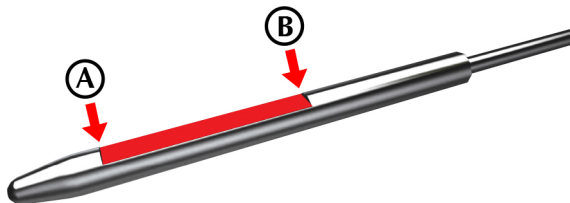

-
8. If more oil is required, top up with the recommended engine oil. **Do not overfill.** For the correct engine oil (Refer to 'Engine Oil', page 6.12).
 9. If more oil is added, do steps 3 to 7 again until the oil level is correct.
 10. Insert the dipstick back into the oil tank and securely tighten the oil filler cap.

Coolant Levels

 **Warning:** *Do not remove a filler cap until the coolant system has cooled. Scalding can be caused by escaping steam or coolant.*

 Use a cloth or glove to protect hands and protect face and arms adequately.

1. Remove the reservoir cap to check the coolant level.
2. Make sure that the reservoir cap is secure after topping up.

 **Caution:** *Do not over tighten the reservoir cap. This can cause damage to the reservoir cap or the thread for the reservoir tank.*

Coolant Identification

Engine Coolant/ERS Coolant



Battery Coolant

⚠ Warning: Do not mix battery coolant with ERS coolant or engine coolant. Incorrect coolant for the high voltage battery can cause irreparable damage that can cause serious injury.



Brake Fluid Level

⚠ Warning: Do not drive the vehicle if the brake fluid level is below the minimum mark in either reservoir.

⚠ Caution: Make sure that the brake fluid does not contact the paint work during the topping up operation. Serious paint work damage can result. If a spillage does occur, immediately flush any brake fluid from the paint work with clean, fresh water and then wipe with a clean damp cloth.

The brake fluid level should read between the Min. and Max. marks.

1. Remove the reservoir cap. Top up to the Min. fill line.



2. Install the reservoir cap securely.

Fluid Specifications

Fuel

Minimum 95 RON unleaded fuel.

Recommended 99 RON Super unleaded for optimum performance.

Use of fuel with more than 10% ethanol is not permitted.



Engine Oil

! Caution: *To achieve the required high performance of synthetic lubricants, do not mix with mineral oils.*

A fully synthetic 0W-40 oil meeting the specifications detailed below can be used. No other viscosity grades or specifications are acceptable.

Authority	Standard
API	SN
ACEA	A3/B4

Coolant

Engine Coolant

Glysantin BASF G40 (70% water to 30% BASF G40 mix)

ERS Coolant

Glysantin BASF G40 (70% water to 30% BASF G40 mix)

High Voltage Battery Coolant

Galden HT170

Brake Fluid

Castrol React SRF Racing Dot 4

Air Conditioning Refrigerant

HFO-1234yf

Air Conditioning Compressor Oil

! Caution: *Only a non-conductive Polyalkylene Glycol (PAG) oil can be used in the HV compressor. Standard PAG oils are conductive and will cause irreparable damage to the compressor.*

Sanden SPA-2

Chassis Systems

Transmission Oil

Castrol Transmax Limited Slip LL 75W-140

Hydraulic Fluid

Pentosin CHF 202

Power Steering Fluid

Pentosin CHF 202

Fire Suppression System

Novec 1230

Capacities

Fuel Tank	50 Litres
Engine Oil (including filter)	10.0 Litres
Engine Coolant (Includes ERS coolant)	10.5 Litres
HV Battery Coolant	2.0 Litres
Transmission Fluid	6.0 Litres
Hydraulic System	4.9 Litres
Power Steering Fluid	0.3 Litres
Screen Washer Reservoir	1.6 Litres
Brake Fluid	1.0 Litres

Vehicle Body

Two door coupe with 2+0 seating with carbon fibre monocoque body structure.

Steering

Electro-hydraulic assisted, rack and pinion power steering. Column adjustment for reach and tilt.

Turns Lock to Lock

1.9 turns.

Turning Circle

14 m.

Suspension

Independent double stainless steel wishbones. Inboard hydraulically actuated torsion bars with active ride height adjustment and damping control. Active pitch and roll control.

Brakes

Foot Brake

	Front	Rear
Disc Construction	Ventilated Carbon Ceramic	Ventilated Carbon Ceramic
Diameter	420mm	385mm
Calipers	Six Piston	Six Piston

Park Brake

Electrically operated independent park brake calipers on each rear brake disc.

Chassis Features

- Anti-Lock Braking System (ABS).
- Electronic Brake Force Distribution (EBD).
- Ten-stage Adjustable Traction Control.
- Dynamic Wheel Torque by Brake (DWT-B).
- Height adjustable suspension.

Wheels and Tyres

Wheel and Tyre Information

Summer And Track Tyres

	Front	Rear
Wheel Size	9.5J x 20	11.5J x 21
Tyre Size	265/35 ZR20	325/30 ZR21
Tyre Pressure (Road Use)	2.2 Bar 32 Psi	2.2 Bar 32 Psi
Tyre Pressure (High Speed ¹)	2.8 Bar 40 Psi	2.8 Bar 40 Psi

¹. Sustained use above 250 km/h (155 mph)

Tyre Loading

Tyres installed to this vehicle shall have a maximum load rating not less than 775 kg (1708 lbs) front and 1000 kg (2205 lbs) rear, or a load index of 99 (front) and 108 (rear).

Winter Tyres

	Front	Rear
Wheel Size	9.5J x 20	11.5J x 21
Tyre Size	265/35 ZR20	315/30 ZR21
Tyre Pressure	2.2 Bar 32 Psi	2.2 Bar 32 Psi

Tyre Loading

Tyres installed to this vehicle shall have a maximum load rating not less than 775 kg (1708 lbs) front and 925 kg (2040 lbs) rear, or a load index of 99 (front) and 105 (rear).

Tyre Pressures

Make sure that correct tyre pressures are carefully maintained. Road holding, steering, braking and tyre wear are especially vulnerable to incorrect tyre pressures.

Check tyre pressures regularly and before starting any journey, and adjust accordingly.

Tyre pressures increase slightly when the tyres are hot. For an accurate reading, tyre pressures should be checked when the tyres are cold. After adjusting the tyre pressures, make sure that the valve caps are securely replaced to provide an additional air seal and to prevent the ingress of dirt.

Tyre Information

Tyres of the correct type, manufacturer and dimensions, with correct cold inflation pressures are an integral part of every vehicle's design. Regular maintenance of tyres contributes not only to safety, but to the designed function of the vehicle.

Road holding, steering and braking are especially vulnerable to incorrectly pressurised, badly installed or worn tyres.

Tyres of the correct size and type, but made by different manufacturers can have widely varying characteristics.

Damage

 *Because of the high performance potential of this vehicle, Aston Martin strongly recommend replacement of any damaged or worn tyre.*

Tyres should be examined at regular intervals for wear and damage. Inspect the tyre treads and sidewalls for damage, i.e. bulges in the tread or the sidewalls, cracks in the tread groove and separation in the tread or the sidewalls. If damage is observed or suspected have the tyre inspected by a tyre professional.

Stones or other objects which have become lodged in the tyre treads should be carefully removed.

Flat Spots

It is a characteristic of high performance tyres that temporary 'flat spots' may develop if the vehicle is left standing in high or low ambient temperatures for any length of time.

These 'flat spots' will manifest themselves as minor vibrations when the vehicle is first driven from cold. As the tyres warm up to operating temperature, normal tyre shape should be restored and the vibrations cease. If vibrations persist, consult your Aston Martin Dealer.

Age

 *Local regulations on tyre life may apply.*

Tyres degrade over time, even when they are not being used. It is recommended that tyres generally be replaced after six years of normal service. Heat caused by hot climates or frequent high loading conditions can accelerate the aging process.

New Tyres

Each wheel and tyre unit must be balanced dynamically and measured for Radial Force Variation (RFV) to make sure of efficient steering, optimum tyre wear and maximum ride comfort. Because of the potentially high speeds, it is essential that wheel balancing is carried out when new tyres are installed. Contact your Aston Martin Dealer for more information.

Running-In New Tyres

When new tyres have been installed, speed should be limited, particularly during the first 80 km or so of driving. Fast cornering, hard braking, and harsh acceleration should also be avoided during this period.

Tread Wear Marks

Tread wear marks (A) are incorporated into the construction of all tyres. These marks are integral moulded ribs spaced at regular intervals around the circumference of the tyre and extend across the full width of the tread, in all primary grooves.

When a tyre has worn causing one or more of the marks to be flush with the outer face of the tread the tyre has reached its wear limit. It then becomes illegal in certain countries and must be replaced.



Summer Tyres

The recommended tyres for this vehicle are asymmetrical and must be installed to the wheel with the tyre mark 'OUTSIDE' on the outside of the wheel rim.

The tyres are also of different sizes on the front and rear axles, therefore complete wheels cannot be swapped between axles.

Winter Tyres

The tyres installed as original equipment are designed with a rubber compound, tread pattern and width specially suited for high speeds in normal road conditions, but they are less suitable during extremes of low temperatures, snow and ice. The use of winter tyres will considerably improve handling during these conditions.

⚠ Warning: The maximum speed limit of the vehicle should be reduced when winter tyres are installed. Winter tyre speed limits and information should be provided upon installation. Please consult your Aston Martin Dealer for more information.

📖 Winter tyres can not be fitted if the optional track clam is installed.

Winter tyres must be used in vehicle sets, that is, installed on all four wheels. Do not exceed the tyre speed rating when using winter tyres.

Snow Traction Devices

⚠ Warning: The maximum speed when using snow traction devices is 50 km/h (31 mph). Remove the snow traction devices immediately when the roads are clear of snow.

These are for temporary use when driving in heavy snow conditions. Snow traction devices should only be installed to the rear (driven) wheels. For more information regarding the correct snow traction device to fit to your vehicle, contact your Aston Martin Dealer.

Fuses

The electrical systems are protected by fuses. If any lamps, accessories, or controls do not function, inspect the applicable fuse.

If a fuse has blown, the inside element will be melted. If the same fuse blows again, avoid using that system and consult your Aston Martin Dealer as soon as possible.

Engine Fuse Box

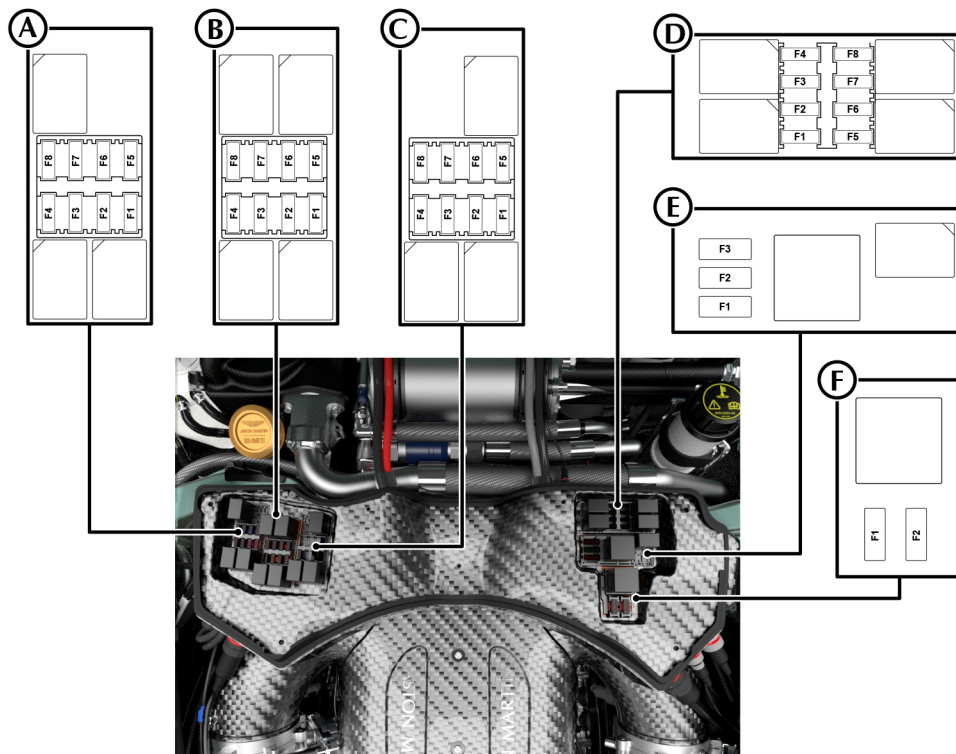

Fuse Box (A)

F1	5A	Secondary Air Valves
F2	4A	Water Run-on Pump
F3	3A	Engine Management System (EMS) Master Relay
F4	20A	EMS Master Relay
F5	5A	DMTL Purge Valve
F6	3A	Tyre Pressure monitoring System (TPMS)
F7	3A	EMS Slave Relay
F8	20A	EMS Slave Relay

Fuse Box (B)

F1	5A	Bank B VVT Solenoids
F2	7.5A	Bank B Fuel Injectors
F3	5A	Bank A VVT Solenoids
F4	7.5A	Bank A Fuel Injectors
F5	7.5A	Bank B Lambda Sensor
F6	10A	Bank B Ignition Coils
F7	7.5A	Bank A Lambda Sensor
F8	10A	Bank A Ignition Coils

Fuse Box (C)

F1	7.5A	Right Side Exhaust Bypass
F2	7.5A	Left Side Exhaust Bypass
F3	-	Not Used
F4	3A	Left Side Radiator Fan
F5	3A	Right Side Radiator Fan
F6	-	Not Used
F7	-	Not Used
F8	-	Not Used

Fuse Box (D)

F1	30A	Left Electric park Brake (EPB) Supply
F2	15A	Direct Drive Valve (DDV) - Suspension
F3	30A	Transmission ECU
F4	3A	Cabin Accelerometers
F5	30A	Right EPB Supply
F6	7.5A	Left Side DDV - Gearbox
F7	30A	ACU Module
F8	7.5A	Left Side DDV -Aero

Fuse Box (E)

F1	40A	Right Side Radiator Fan
F2	30A	Charge Port
F3	40A	Left Side Radiator Fan

Fuse Box (F)

F1	50A	Left Side Secondary Air Pump
F2	50A	Right Side Secondary Air Pump

Cabin Fuse Box

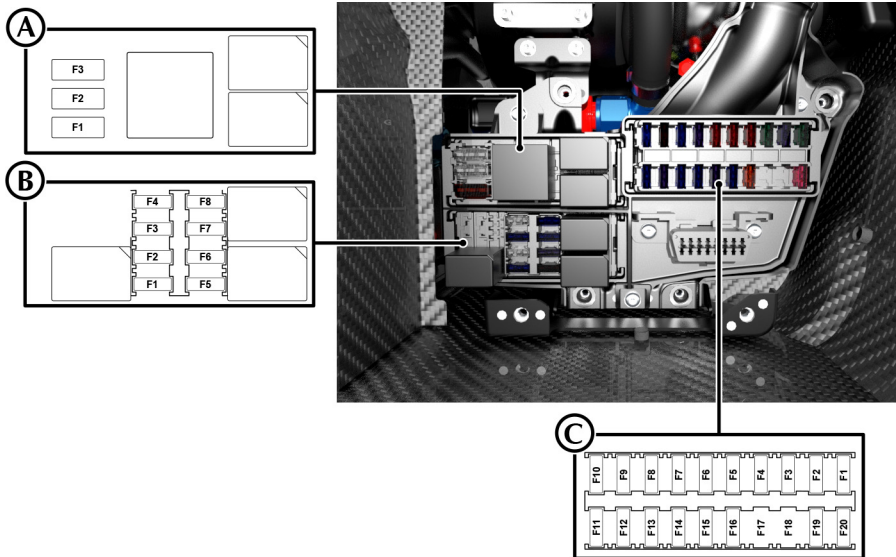

Fuse Box (A)

F1	40A	ESP Modulator Motor
F2	25A	ESP Modulator Valve and Module
F3	25A	Fuel Pump

Fuse Box (B)

F1	15A	Body Control Module
F2	25A	Heated Screen
F3	15A	High Voltage Battery
F4	25A	Fuel Pump
F5	7.5A	Infotainment
F6	3A	Steering Wheel
F7	15A	Right Side Horn
F8	15A	Left Side Horn

Fuse Box (C)

F1	30A	Wiper Motor
F2	3A	DC/DC Converter
F3	30A	HVAC Fan
F4	10A	HVAC Module
F5	10A	Passive Entry Passive Start (PEPS) Controller A
F6	10A	PEPS Controller B
F7	3A	Mirror Cameras
F8	2A	Intercom
F9	7.5A	Door Latch
F10	15A	Left Side Lamps
F11	15A	Right Side Lamps
F12	3A	Map Lamp
F13	15A	Inverter
F14	15A	ERS Coolant pump
F15	3A	Fire Suppression
F16	3A	On board Diagnostics (OBD)
F17	-	Not Used
F18	-	Not Used
F19	4A	Interior Mirror
F20	4A	Ignition Signal Rain Light Sensor Fire Suppression Switch Illumination

12V Battery

Battery Warnings

⚠ Warning: Do not allow flames, sparks or lighted substances to come near the battery. Exposing battery cell to excessive heat, fire or over voltage condition may cause a leak, fire, hazardous vapors and hazardous decomposition products. Damaged or opened cells or batteries can result in rapid heating and the release of flammable vapors.

⚠ Warning: Never place metal objects on the battery or allow the positive terminal of the battery to contact parts of the vehicle body. This can create a spark or a short circuit which can ignite gases created when the battery is charged.

⚠ Warning: Never use a damaged battery. If a battery has leaking fluids, do not touch the fluids. Contact an Aston Martin Dealer for advice on safe disposal of the battery. In case of skin contact with fluid, immediately wash thoroughly with water for at least 30 minutes, until no evidence of the fluid remains. Seek medical attention

⚠ Warning: In case of eye contact with fluid, do not rub eyes. Immediately flush eyes thoroughly with water for at least 30 minutes, lifting upper and lower lids, until no evidence of the fluid remains. Seek medical attention

⚠ Warning: Keep batteries out of reach of children.

⚠ Caution: The engine must never be run with the vehicle battery disconnected. This can cause damage to vehicle electrical modules.

Vehicle Battery: Super-B AMV Battery 12.9 Ah

The vehicle battery is maintenance free and should only require checking by your Aston Martin Dealer during regular vehicle services.

HV Battery

⚠ Warning: The HV battery must never be used in a jump start scenario to either supply or receive power. There is risk of serious damage to the batteries and the electrical system on one or both vehicles, which can cause injury or death.

⚠ Warning: Never connect external electrical equipment, such as a battery charger, to the HV battery. There is risk of serious damage to the batteries and the electrical system, which can cause injury or death.

HV Battery:

The 300V battery is the main vehicle power source and acts as an energy store to power the electronic components of the hybrid drive system and is maintenance free. This battery must only be checked by your Valkyrie Service Centre and is not user serviceable.

Charging

 *The HV battery is not charged within the first two minutes after each vehicle start.*

The HV battery is charged using the E-Motor by using excess engine power. There is no direct external charge point for the HV battery. If the HV battery is drained down to 0% the vehicle must be recovered to an Aston Martin Dealer.

12V Battery Level Protection

Using vehicle electrical systems such as the infotainment system, with the ignition on, but the engine off, will drain the battery charge.

To prevent battery voltage falling below the level required to start the vehicle, the vehicle's battery monitoring system will shut down non-essential electrical systems before this happens.

After approximately 2 to 10 minutes (dependent on the rate of battery charge drain) a message is shown in the infotainment display.

If a low battery warning message shows, connect the supplied battery charger or conditioner. If running the engine to charge the HV battery, allow the vehicle to idle for approximately 15 minutes. This will be sufficient to recharge the battery from 0% to 80%.

Vehicle Battery Disposal

The incorrect disposal of a vehicle battery can be extremely hazardous to health and the environment. Most batteries contain materials that, when disposed of incorrectly, may leak into the environment. This can contribute to soil and water pollution and endanger wildlife.

Do not dispose of a battery in fire or water.

Follow your local authorised standards for disposal. Contact your Aston Martin Dealer to find out more about recycling automotive batteries. Do not dispose of your vehicle battery in the household waste.



Battery Conditioner

⚠ Caution: Do not attempt to start the vehicle with a battery conditioner connected to the mains supply.

 *The battery conditioner is only used to charge the 12V battery.*

If this vehicle is not going to be used for a period of time, and mains power is available, use the supplied battery conditioner to maintain the charge level of the 12V battery. When connected, the battery conditioner will maintain a small trickle charge to keep the 12V battery in a fully charged state. The battery conditioner is designed for conditioning of partially or fully charged batteries. It will not effectively charge a discharged battery.

To attach the battery conditioner, remove the cover plate (A) and attach the conditioner to the circular connector (B).

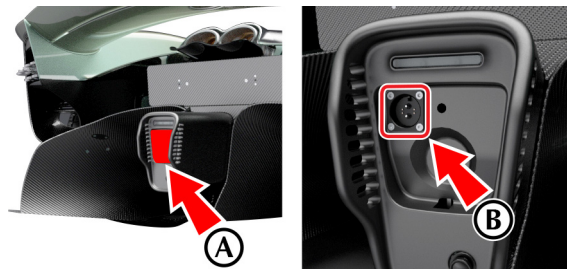

 *For further safety information and operating instructions, refer to the instructions supplied with the battery conditioner.*

Vehicle Care

Lamps

External Lamps

All external lamps use LEDs and are contained in a sealed lamp units.

The lamp units are not repairable. If a lamp or lamp unit fails contact your Aston Martin Dealer.

Internal Lamps

All internal lamps are LEDs and are not repairable.

If an LED lamp fails contact your Aston Martin Dealer.

Washing

 **Warning:** *Washing and polishing agents containing silicone should not be applied to glass. This will reduce the efficiency of the windscreen wipers, causing smears which will reduce visibility, particularly during darkness and in the rain.*

 **Caution:** *Commercially operated automatic vehicle washes are not recommended. Parts of the bodywork may become damaged as the vehicle was not designed for use in automatic car washes. The detergents used can also contain certain chemicals which may, over time, be detrimental to some exterior parts of the vehicle.*

 **Caution:** *Jet washes and power operated mops are not recommended. Prolonged usage of power operated mops will also cause fine scratches in the paint surface.*

 *Before this vehicle is washed, make sure the tow eye or front jack adapter is not installed. The threaded hole for the tow eye also functions as a drainage hole for the front clamshell.*

Aston Martin are able to supply a range of products to clean and protect your vehicle. Contact you Aston Martin Dealer for further information.

During the winter months, it is advisable to wash the vehicle more frequently, paying particular attention to the underside to combat the detrimental effects of any salt and sand contamination picked up from treated roads.

To delay the onset of corrosion developing on the brake components, Aston Martin recommend that after washing this vehicle, the vehicle should be driven a short distance to make sure that all water and cleaning products have dried off.

For best results:

- Do not wash the vehicle in strong sunlight. Let the vehicle cool before washing.
- Do not use household soaps or detergents.
- Do not direct water hoses at full force around the door and seals.
- Do not use a brush on the car body as this will leave little scratches.

Suggested washing method:

1. Fill two buckets with water. Add a mild neutral detergent, as directed by the detergent manufacturer to one of the buckets.
2. Use a hose to remove all dust and mud residue from the vehicle. Don't use a strong jet, as this can rub grit over the paint and scratch it.
3. Soak a large clean wash mitt or a soft clean sponge in the soapy water, and begin applying it to the vehicle. Wash the vehicle section by section, starting at the top. Circle around the car several times, washing lower areas with each round. Rinse the dirt out of the wash mitt or soft sponge in the bucket with plain water frequently.
4. After one section is washed, rinse it with the hose before moving on, don't let the soap dry on the paint as this can stain it. Always keep the vehicle wet, this will prevent droplets from drying on the paint and leaving water-spots.
5. Dry the car with a chamois leather before it air-dries.

Paint Work

Modern water based paints are much safer and more environmentally friendly than solvent based paints. Water based paints are however more susceptible to contamination and marking by corrosive substances. The following list is not exhaustive but does show the most common contaminants which may adversely affect your paint work:

- Bird droppings,
- Antifreeze,
- Tree sap,
- Oils and greases,
- Insect remains.

Wash such substances from the vehicle using clean warm water with vehicle shampoo at the earliest opportunity, especially in sunny weather which can accelerate contamination.

 *Other groups of contaminants may be added to this list as experience of water based paints and finishes increases.*

Satin Paint

(Optional)

⚠ *The Aston Martin new car warranty covers defects in materials or workmanship of the paint work. The warranty does NOT cover repairs to your satin or matt paint work caused by negligence, lack of or improper maintenance such as waxing or polishing the finish, environmental influences, or improper repairs or damage that causes the satin finish to become glossy.*

In comparison to conventional paints with a gloss or metallic surface, satin paint work must be cared for slightly differently. In order to avoid damage to the satin paint work, make sure that the cleaning and care points below are followed:

1. Only use cleaning products recommended by Aston Martin. Abrasive cleaning products will change the satin appearance of the paint and must not be used.
2. Do not polish or wax the paintwork. This can lead to glossing of the paintwork.
3. Do not wash the car in an automatic car wash. This will avoid particles such as sand and dust, from damaging the painted surface.
4. Only use a soft sponge to clean the vehicle. Do not use abrasive cleaning tools.
5. Remove insect remains, bird droppings, resins, tar spots, fuels and oil immediately. Avoid strong rubbing while cleaning the vehicle.
6. Any stickers applied to the paint work will leave a mark when removed.
7. Repairs to the paint work must be completed by an Aston Martin body shop.

Ceramic Brake Discs

To avoid possible damage to the ceramic brake discs, when washing the road wheels with products or materials other than a mild soapy water solution always remove the wheels from the vehicle.

Road Wheels

To avoid possible damage to the alloy road wheels, wheel nuts and wheel centre trims, from a build up of brake dust wash and clean the alloy road wheels frequently, using a mild soapy water solution only. Do not use chemical alloy road wheel cleaners, as they can often have a high acid or alkaline content and could cause discolouration. Always clean one wheel at a time and do not allow the cleaning solution to dry on the wheel. Fully flush off with clean water.

Headlamp Lenses

Only use a mild soapy water solution when washing the headlamp lenses. Do not use cleaning materials which contain solvents.

Cleaning materials which contain solvents, i.e. tar remover, petrol, waxes or polishes, may damage the headlamp lens.

Under Bonnet Cleaning

Under bonnet cleaning using high pressure hoses or steam cleaners should not be carried out. The electronic control module connections and fuse boxes can be damaged by indiscriminate use of high pressure cleaning equipment.

Polishing

Approximately twice a year, a good quality polish should be applied to the body work and then buffed, using a soft lint free cloth.

The alloy wheel rims should be treated with a cleaner which is specifically manufactured for this purpose.

Care and Maintenance of Seat Belt Harnesses

To make sure that the restraint webbings are in correct working order, regularly check the seat belt harnesses. Look for fraying, cuts, burns and similar problems. Make sure that the latches and buckles operate correctly. If a seat belt harness is not in good condition or is not working correctly, consult an Aston Martin Dealer.

To clean the seat belts, use warm water; do not use bleach, solvents or dyes, as they can weaken the material. Allow the seat belts to dry thoroughly before use.

Trim and Seats

⚠ Warning: Fumes from cleaning solvents may be dangerous in confined spaces. Make sure that the vehicle is well ventilated and follow the manufacturer's printed instructions when using these products.

The carbon fibre trim should be cleaned using a dry clean lint free cloth.

Alcantara®¹ trimmed areas may be brushed with a soft brush, a dry cloth or a vacuum cleaner.

To clean Alcantara, dust the material with care; moisten a soft cloth or a sponge in clean water, wring it thoroughly and run it over the whole Alcantara material, making sure not to wet it excessively. Rinse the cloth or sponge and repeat as necessary. Leave to dry overnight. Once dried, brush it delicately with a soft bristle brush.

Stains from water based substances such as coffee, tea or soft drinks should be cleaned as soon as possible with lukewarm water. If necessary, use lemon juice to remove discolouration. For stains that may coagulate, such as blood, rinse by dabbing with clean water instead of warm water.

For stains that are not water soluble, rub with ethyl alcohol and rinse with water.

Consult an Aston Martin Dealer for instructions on the removal of more difficult stains such as oil, grease or ballpoint ink.

¹ Alcantara is the registered trademark of Alcantara SPA, Italy and used with permission

Powertrain Specifications

Engine

48 valve naturally aspirated V12 hybrid engine featuring:

- Gear driven quad-variable camshaft timing.
- Dry sump lubrication system.
- Auxiliary E-Motor

Engine Capacity

6500 cc (397 CID).

98 mm (3.85 inch) Bore.

71.8 mm (2.83 inch) Stroke.

Compression Ratio

13.5:1.

Firing Order

1-7-2-8-3-9-6-12-5-11-4-10.

Fuel delivery

Twin port multi-point sequential fuel injection.

Idle Speed

1200 rpm.

Ignition

'Coil on Plug' Ignition System.

Lubrication

Dry sump pressurised system with external oil tank.

Transmission

Twin barrel seven-speed transmission with E-synchronisation and electric reverse.

Direct mount to engine as stressed member.

Gear Ratios

1st	2.850
2nd	2.080
3rd	1.571
4th	1.242
5th	1.024
6th	0.884
7th	0.796
Reverse	2.850
Final	2.909

Performance

Maximum Power (Engine)	746 kW 1001 Bhp at 10,600 rpm
Maximum Power (E-Motor)	125 kW 168 Bhp
Maximum Engine Speed	11,100 rpm
Maximum Torque (Engine)	780 Nm 575 Lb.ft at 7000 rpm
Maximum Torque (E-Motor)	280 Nm 206 Lb.ft
Maximum Speed - limited (Where Permitted)	220 mph 355 km/h

Dimensions

Vehicle Weights

Unladen Mass	1355 kg / 2987 lbs
Gross Vehicle Weight (GVW)	1545 kg / 3406 lbs
Towing Capacity	Not Applicable

Towing

This vehicle is not engineered to tow any form of caravan, boat or trailer. No towing devices are approved to install to this vehicle, other than front and rear towing eyes to aid recovery of loading of this vehicle onto a transporter. The towing eyes are for recovery of this vehicle only and this vehicle must not be used to tow other vehicles.

External Dimensions

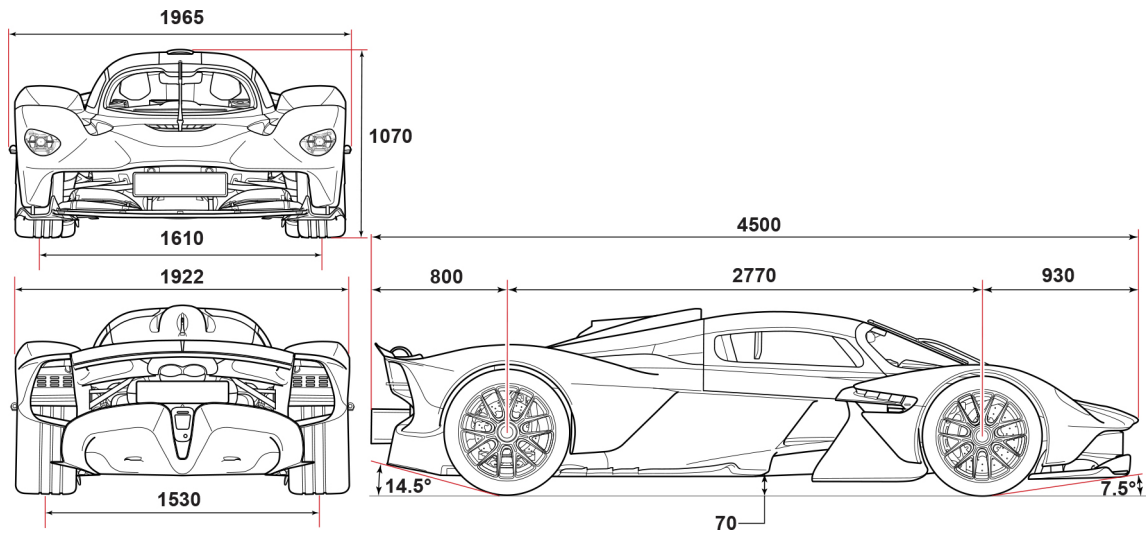

All dimensions shown in mm.

Emergency and Breakdown

Emergency Items

The following emergency items are stored in the front stowage compartment for emergency use:

- Tyre repair kit
- Fuel filler funnel
- Towing eye
- M5 hex drive key (for front license plate and plinth)

A first aid kit is also stored behind the front license plate.

Front License Plate Plinth Removal

For the vehicle to be lifted at the front or for the front eye to be installed, the plinth for the front license plate must be removed.

1. Remove the two screws that attach the front license plate.



2. Remove the ten screws that attach the front number plate plinth.

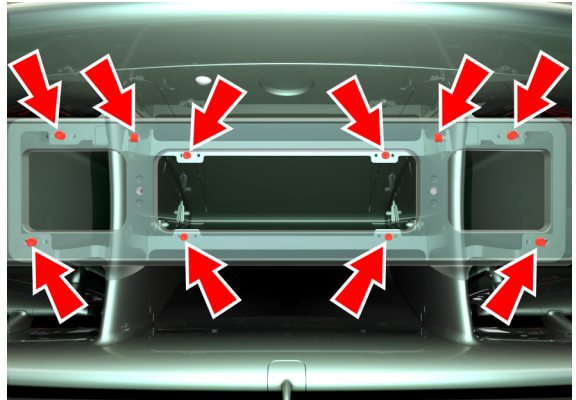

Vehicle Recovery

⚠ Caution: *When the vehicle is moved by transporter make sure that the vehicle is not strapped down by the suspension control arms. Strap the wheel down between the spokes of the wheel.*

⚠ Caution: *Power steering is not available with the engine off. Substantially higher steering effort will be required.*

⚠ Caution: *Do not tow this vehicle for distances of more 500m (165 ft) and more than 20 km/h (12 mph). Do not tow the vehicle at all if the transmission is stuck in gear. Doing so will cause significant damage to the transmission, hybrid components and engine.*

⚠ Caution: *The towing eyes are for recovery of this vehicle only and this vehicle must not be used to tow other vehicles.*

If the park brake was applied and the vehicle has lost power, the park brake will not release. Call Aston Martin Assistance or your local Aston Martin Dealer.

Your vehicle should always be recovered on a vehicle transporter and should only be towed for **short distances** of up to 500 m (0.3 mile). For example, if the vehicle is causing an obstruction or if requires winching onto a transporter.

⚠ Caution: *The transmission must be in Neutral (N) for this vehicle to be towed. If the vehicle has stalled in gear, press the N button on the steering wheel immediately after the vehicle stalls. If this fails and the transmission cannot be set to neutral, then wheel skates must be used to move the vehicle. If the vehicle is moved whilst in gear, serious damage can occur to the transmission, hybrid components and engine.*

If moving the vehicle in such a situation:

1. (Front only) Remove the plinth for the front license plate (Refer to 'Front License Plate Plinth Removal', page 6.34).
2. Remove the front (A) or rear (B) tow eye cover and install the tow eye.

 *The tow eye has a left hand thread.*

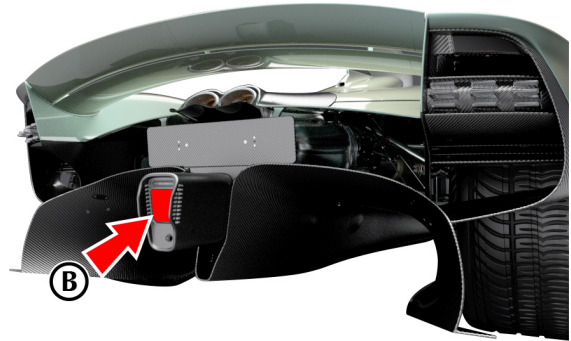
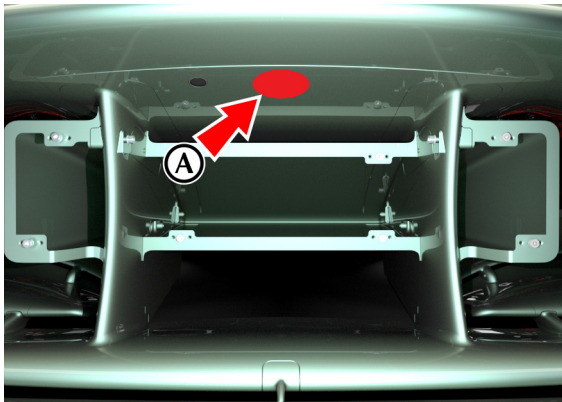

3. When being towed, use the footbrake very gently when required, to prevent excessive slack in the tow rope.

Vehicle Push Points

⚠ Caution: Do not push the vehicle by the rear spoiler, rear bumper, rear towing eye or rear of the front fenders. These panels are not designed to take the force required to push the vehicle.

If the vehicle must be pushed to move it, open the doors and push using the A-pillars, side pods or rear quarter panels as shown below. If pushing backwards you may also push in the centre of the front clamshell or above the headlamps.

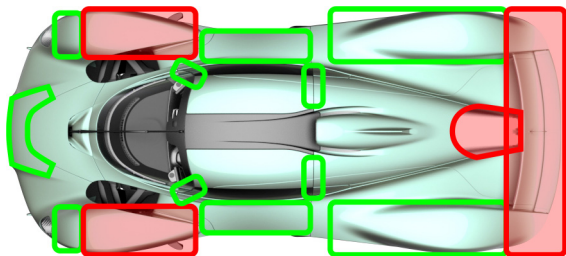

Vehicle Lifting

⚠ Warning: Make sure that no persons are in the vehicle before the vehicle is lifted.

⚠ Warning: Make sure that the park brake is applied and that the vehicle is parked on firm and level ground to give a secure base for the lifting equipment.

⚠ Warning: Do not lift the vehicle by placing a jack or other lifting equipment under the suspension arms, body or any other points than the lifting points shown.

⚠ Warning: The pin insert must be installed into the front jacking point, and the rear lifting cradle must be installed before lifting. If you do not, there is a risk that the vehicle may slip off the jack.

 The plinth for the front license plate must be removed before installing the pin insert (Refer to 'Front License Plate Plinth Removal', page 6.34).

If this vehicle is to be raised, make sure that the below front (A) and rear (B) jacking points are used and only with the correct supplied lifting equipment.

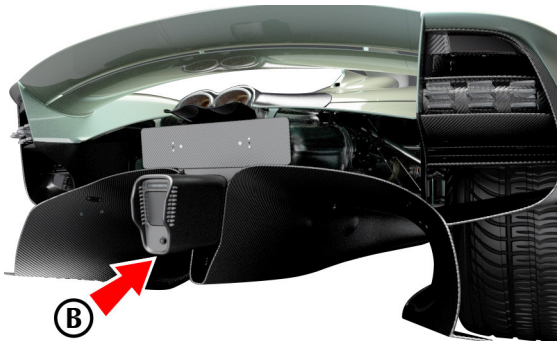
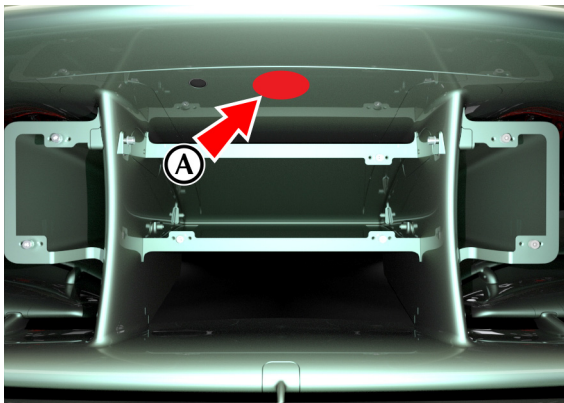

Centre Lock Wheels

These wheels require specialist tools and should only be removed by an Aston Martin technician.

⚠ Warning: *The centre lock wheel nut and cone should be inspected for damage whenever the wheel is removed. If either component show signs of damage, the must not be used. There is a risk that they will not be able to securely hold the wheel on and may fail. Regardless of any visible damage, both the wheel nut and cone must be replaced at 25,000 km (15,500 miles) or after they have been removed and installed 5 times.*

⚠ Warning: *Wheels should be installed when cold. If the wheels are installed while the wheel and hub are hot, then the torque applied to the wheel can change as they cool down.*

⚠ Warning: *If the vehicle is used for continuous fast driving (such as on a track), check the wheel torque before returning to normal road driving.*

⚠ Warning: *You must not drive the vehicle without the security cap for the centre lock nut installed.*

⚠ Caution: *Before removing the wheel, make sure you have a torque wrench able to torque the wheel nut to 1000 Nm (740 ftlb) and a replacement thrust washer available. If you do not, the wheel must not be removed as you will not be able to safely install the wheel back onto the car.*

⚠ Caution: *Due to the high torque required to release the centre lock nut, all wheels not being removed must be secured to prevent the vehicle moving.*

⚠ Caution: *Do not let the wheel tilt or sit on the thread for the centre lock hub. Doing so can damage the thread for the wheel nut.*

 *Keep the centre lock nut clean when removed from the wheel hub. Replace any grease that has been lost to protect the thread for the centre lock nut.*

To remove the wheel:

1. Apply the park brake.
2. Use the security cap tool to remove the centre cap.
3. Use the security cap tool (A) to release the spring clip (B).
Remove the security cap from the wheel nut with the security cap tool still installed.

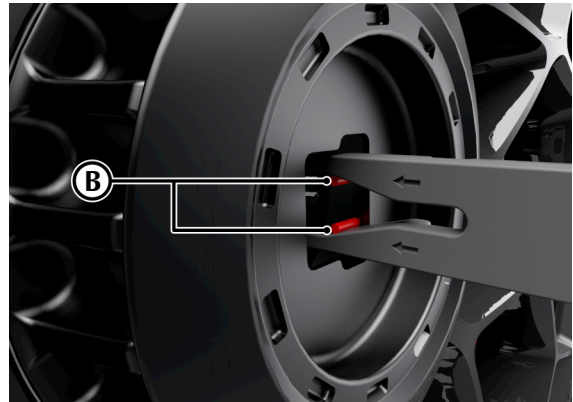
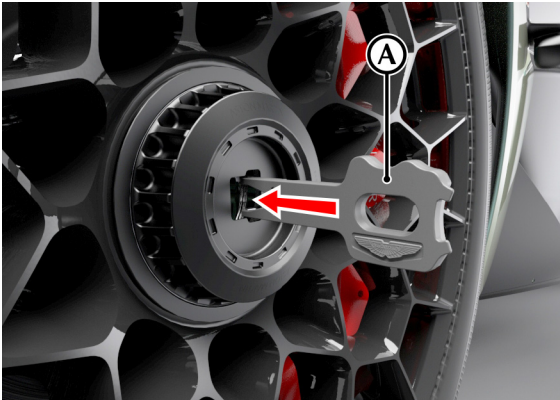

4. Use the centre lock nut socket and a suitable tool to release, but do not remove, the centre lock nut.

 A second person will be required to sit in the driver seat and apply the vehicle brakes.

5. Raise the vehicle so that the wheel lifts off the ground.
6. Remove the centre lock nut and discard the thrust washer.
7. Carefully remove the wheel.

To install the wheel:

 A second person will be required to sit in the driver seat and apply the vehicle brakes when the centre lock nut is tightened.

1. Install a new thrust washer to the centre lock nut.

 Apply grease to the mating surfaces of the thrust washer.

2. Carefully fit the wheel to the drive pegs on the wheel hub.

3. Install, but do not fully torque, the centre lock nut. Make sure the wheel is correctly seated against the wheel hub before the nut is tightened.

4. Lower the vehicle.

5. Using the centre lock nut socket and a suitable torque wrench, torque the centre lock nut to 1000 Nm (740 ftlb).

6. Loosen the wheel to 0 Nm (0 lbft).

7. Torque the centre lock nut to 1000 Nm (740 ftlb) a second time.

8. Loosen the wheel to 0 Nm (0 lbft).

9. Torque the centre lock nut to a final 1000 Nm (740 lbft).

10. Align the security cap the centre lock nut.

 The centre cap tool should still be installed holding the spring clip.

11. Fully install the security cap until it sits flush with the centre lock nut.

12. Remove the security cap tool to engage the spring clip.

 **You must not drive the vehicle without the security cap for the centre lock nut installed.**

13. Install the wheel centre cap.

Tyre Repair Kit

 **Warning: Do not use the system to seal a tyre that was damaged while driving with insufficient air pressure (e.g. tyre cuts, cracks, bumps or similar damage). Do not use the system to seal tyres with side wall damage. Only punctures in the tread area of tyres may be sealed.**

 **Warning: Do not stand directly beside the tyre while the compressor is pumping. Watch the side wall of the tyre. If there are any cracks, bumps or similar damage set the compressor to off. The journey should not be continued. Contact your Aston Martin Dealer.**

 **Warning: If a tyre pressure of 1.8 bar (26 Psi) cannot be reached then the tyre can not be sealed. Do not attempt to re-inflate the tyre. Contact your Aston Martin Dealer.**

 **Warning: If the pressure in the tyre after driving for 3 km is below 1.3 bar (19 Psi) the tyre has not been effectively sealed. The journey should not be continued. Contact your nearest Aston Martin Dealer.**

 **Warning: After a longer period of rest, the tyre pressure should be rechecked.**

 **Caution: The tyre sealant kit only provides temporary mobility. Always refer to local laws and regulations on the use and repair of tyres that have been treated with any form of temporary mobility aid. Consult a tyre specialist for advice.**

 Inform the tyre specialist that the tyre contains sealant.

 Remains of liquid sealant must be handed over to your dealer or disposed of in compliance with local waste disposal regulations. Dispose of empty sealant bottles together with normal household waste.

Operation

Remove the tyre sealant kit from its location in the front stowage compartment. Follow the instructions detailed on the lid.

Read the following instructions and warnings carefully before using the tyre sealant kit. Compliance with these instructions is vital to make sure of vehicle and user safety. Non-compliance with these instructions means risking severe tyre damage and hazardous vehicle behaviour which can lead to a road accident involving damage to property or injury to persons.

- Make sure that the vehicle is parked far enough from traffic so that there is no danger from passing vehicles and so that you do not disrupt the traffic.
Warn other vehicles using the warning triangle.
- A maximum speed of 80 km/h (50 mph) may not be exceeded at any time after sealing the tyre with the system.
- The system provides only a temporary emergency repair for continuing the journey up to 200 km (125 miles) or to the nearest Aston Martin Dealer.
- If the nearest Aston Martin Dealer is over 200 km (125 miles) away, arrange for collection with Aston Martin Assistance.

- The system will effectively seal a tyre that was punctured by an object with a diameter of up to 6 mm. It is possible that a tyre, especially with greater damage, will not be sealed. Do not remove objects that punctured the tyre if they are still lodged in the tyre.
- The sealant bottle needs to be exchanged before it expires. Do not use the system after the expiry date on the sealant bottle or casing has been reached. Contact your nearest Aston Martin Dealer.
- Do not attempt to inflate other objects without using a system adapter and do not inflate objects with a volume greater than 50 litre (air mattresses, rubber boats, etc.). Do not let the system pump air for more than 10 minutes without stopping it and allowing it to cool down.

Both the hose and the bottle of sealant need to be replaced after using the system. Sealant deposits in a used hose may cause the system to operate incorrectly. New bottles of sealant can be purchased from an Aston Martin Dealer.

Fuel

Fuel Filling

 The fuel tank filler neck has a restricted opening which will only accept the fuel supply nozzle of unleaded fuel pumps.

Open the fuel flap by pressing down on the forward bottom edge of the fuel flap.

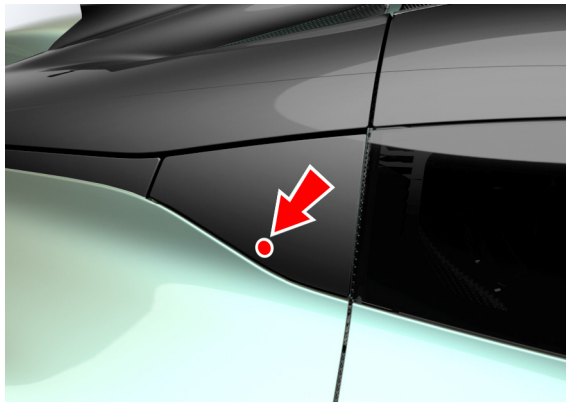

The fuel system will not let the fuel tank overfill but there will be times when the fuel nozzle will shut off prematurely. If this happens only try to fill the fuel tank one more time, continued attempts will result in fuel spillage. Wait 10 seconds before removing the refuelling nozzle.

Fuel Filler Bowl

To stop water gathering in the fuel filler bowl and flowing into the fuel tank, the fuel filler bowl has a pipe to let the water drain from the bowl. During fuel filling, check and make sure that any debris which may block the pipe is removed.

Fuel Cut-Off

In the event of a vehicle accident the vehicle electronics will enter crash mode. Power to the fuel pumps will stop, thereby reducing fire risk.



ASTON MARTIN

Service

Aston Martin Facilities	A.2
Vehicle Provenance.....	A.3
Servicing	A.5
Service Record	A.8
Brake Disc Check.....	A.30
Field Service Actions	A.33
Service Action Recalls.....	A.34

Aston Martin Facilities

A full list of Aston Martin Dealers worldwide can be found at:

www.astonmartin.com

Every effort is made to make sure that the information given in the dealer list is accurate and up-to-date. However changes amongst holders of the Aston Martin franchise can occur. Neither Aston Martin nor any listed Importer or Dealer shall in any circumstances be held liable for any inaccuracy, or the consequences thereof.

Valkyrie Service Centres

Aston Martin Valkyrie requires specialist technicians, specialist equipment and bespoke tooling to perform servicing and maintenance. Most mechanical tasks will not be possible at an Aston Martin dealer. In collaboration with Aston Martin Lagonda Ltd, your Aston Martin Dealer will arrange for your vehicle to be transported to a Valkyrie Service Centre for maintenance to be performed.

All Aston Martin Dealers are independent traders. They are not the Company's Agents, and therefore have no authority to bind the Company or to enter into any financial or other commitments on the Company's behalf.

Only Aston Martin Dealers and Valkyrie Service Centres are authorised to complete warranty work on this vehicle.

Vehicle Provenance

Model:

Vehicle Identification Number:

As on the VIN plate

Body Colour:

First Owner

Selling Dealer

Delivery Date

Second Owner

Selling Dealer

Delivery Date

Third Owner

Selling Dealer

Delivery Date

Fifth Owner

Selling Dealer

Delivery Date

Fourth Owner

Selling Dealer

Delivery Date

Sixth Owner

Selling Dealer

Delivery Date

Servicing

Service Periods

Each item in the service schedules must be performed on time as failure to do so may void the new vehicle warranty or other warranties. It is the owner's responsibility to see that the vehicle is maintained correctly and in accordance with the manufacturer's service schedules.

Due to the nature of this vehicle an initial service is required 1,000 km (600 miles) after delivery. Vehicle servicing is then every 5,000 km, 3,100 miles or 12 months, which ever occurs first.

- 1,000 km / 600 miles Initial service
- 5,000 km / 3,100 miles or 12 months
- 10,000 km / 6,200 miles or 24 months
- 15,000 km / 9,300 miles or 36 months

Service Tables

The following service schedules are recommended for this vehicle. The schedules may be modified if necessary. Please consult your Aston Martin Dealer for details of any service schedule updates.

Item

Annual Service Inspections

Examine the condition, operation, adjustment and attachment of the below items:

Check engine and transmission for leaks and wear (including swelling of oil hoses).

HV Battery. Examine for leaks in battery coolant and ERS coolant.

Fuel system. Examine for leaks and wear.

Cooling system. Examine for leaks.

Air conditioning.

Drive shafts.

Hydraulic system. Check for leaks

Suspension and steering system. Examine for leaks and wear.

Brake system including park brake. Examine for leaks and wear.

Wheels, tyres and tyre pressure monitoring system. Check tyre pressures and adjust as necessary.

Item

Annual Service Inspections

Exhaust system, heat shields and bypass valves. Check for leaks.

Active aero body components.

Lamp units and the vehicle horn.

Windscreen wiper blades and wash system including fluid levels and adjust accordingly. Examine for leaks and wear.

Occupant restraints.

Fire suppression system.

Locks, latches and hinges. Lubricate any joints as necessary.

Instrument cluster and warning symbols.

Camera system.

Inspect and clear body drainage holes.

Service Intervals

⚠ Caution: Use of this vehicle in a track environment can drastically reduce the life of some of the below components. Always contact your Aston Martin Dealer before this vehicle is used on track.

Item

Replace the oil and oil filter for the engine.	Initial: 1,000 km / 600 miles Regular: 5,000 km / 3,100 miles / 12 months
Replace the spark plugs.	25,000 km / 15,500 miles
Replace the air filters.	5,000 km / 3,100 miles / 12 months
Replace the pollen filters.	5,000 km / 3,100 miles / 12 months
Replace the AC gas	12 Months
Replace the oil, oil filter and drain plug for the transmission.	Initial: 1,000 km / 600 miles Regular: 10,000 km / 6,200 miles
Rebuild the transmission.	50,000 km / 31,000 miles
Inspect the clutch slave cylinder.	10,000 km / 6,200 miles
Inspect the clutch.	15,000 km / 9,300 miles
Replace the oil and oil filter for the hydraulic system.	10,000 km / 6,000 miles / 48 months
Replace the pump shaft for the hydraulic system.	25,000 km / 15,500 miles
Replace engine coolant..	12 months
Replace the ERS coolant.	10,000 km / 6,200 miles / 36 months
Replace the HV battery coolant.	10,000 km / 6,200 miles / 36 months
Replace the brake fluid.	12 Months
Fire suppression canister.	24 months
Replace the rear half-shafts.	100,000 km / 62,000 miles
Replace the fuel drive unit.	50,000 km / 31,000 miles
Replace the alignment straps for the seat harnesses.	12 Months
Replace the seat harnesses.	5 Years
Replace the centre lock wheel nuts and cones.	10,000 km / 6,000 miles or every 5 wheel changes

Service Record

The following service records cover the initial service and regular services at 5,000 km (3,100 miles) or 12 months intervals, whichever occurs first. Make sure that at each service the appropriate entry is stamped and signed as completed.

Vehicle Model:

Registration Number:

Vehicle Identification Number (VIN):

Delivery Date:

Free Pre-delivery Inspection

Service Actions Checked: Yes / No

Open Service Actions Completed: Yes / No

Signature:

Date:

Initial Service Stamp

Odometer:

Service Advisor Name:

Service Advisor Signature:

Service Information

Odometer:

Technician Name:

Date:

Next Service Due:

Authorised Dealer Stamp

Service Advisor Name:

Service Advisor Signature:

Service Details

Service Actions Checked: Yes / No

Air Filter Changed: Yes / No

Pollen Filter Changed: Yes / No

Spark Plugs Changed: Yes / No

Fire Suppression Fluid Replaced: Yes / No

Fluids Changed:

Additional Service Information

Service Information

Odometer:

Technician Name:

Date:

Next Service Due:

Authorised Dealer Stamp

Service Advisor Name:

Service Advisor Signature:

Service Details

Service Actions Checked: Yes / No

Air Filter Changed: Yes / No

Pollen Filter Changed: Yes / No

Spark Plugs Changed: Yes / No

Fire Suppression Fluid Replaced: Yes / No

Fluids Changed:

Additional Service Information

Service Information

Odometer:

Technician Name:

Date:

Next Service Due:

Authorised Dealer Stamp

Service Advisor Name:

Service Advisor Signature:

Service Details

Service Actions Checked: Yes / No

Air Filter Changed: Yes / No

Pollen Filter Changed: Yes / No

Spark Plugs Changed: Yes / No

Fire Suppression Fluid Replaced: Yes / No

Fluids Changed:

Additional Service Information

Service Information

Odometer:

Technician Name:

Date:

Next Service Due:

Authorised Dealer Stamp

Service Advisor Name:

Service Advisor Signature:

Service Details

Service Actions Checked: Yes / No

Air Filter Changed: Yes / No

Pollen Filter Changed: Yes / No

Spark Plugs Changed: Yes / No

Fire Suppression Fluid Replaced: Yes / No

Fluids Changed:

Additional Service Information

Service Information

Odometer:

Technician Name:

Date:

Next Service Due:

Authorised Dealer Stamp

Service Advisor Name:

Service Advisor Signature:

Service Details

Service Actions Checked: Yes / No

Air Filter Changed: Yes / No

Pollen Filter Changed: Yes / No

Spark Plugs Changed: Yes / No

Fire Suppression Fluid Replaced: Yes / No

Fluids Changed:

Additional Service Information

Service Information

Odometer:

Technician Name:

Date:

Next Service Due:

Authorised Dealer Stamp

Service Advisor Name:

Service Advisor Signature:

Service Details

Service Actions Checked: Yes / No

Air Filter Changed: Yes / No

Pollen Filter Changed: Yes / No

Spark Plugs Changed: Yes / No

Fire Suppression Fluid Replaced: Yes / No

Fluids Changed:

Additional Service Information

Service Information

Odometer:

Technician Name:

Date:

Next Service Due:

Authorised Dealer Stamp

Service Advisor Name:

Service Advisor Signature:

Service Details

Service Actions Checked: Yes / No

Air Filter Changed: Yes / No

Pollen Filter Changed: Yes / No

Spark Plugs Changed: Yes / No

Fire Suppression Fluid Replaced: Yes / No

Fluids Changed:

Additional Service Information

Service Information

Odometer:

Technician Name:

Date:

Next Service Due:

Authorised Dealer Stamp

Service Advisor Name:

Service Advisor Signature:

Service Details

Service Actions Checked: Yes / No

Air Filter Changed: Yes / No

Pollen Filter Changed: Yes / No

Spark Plugs Changed: Yes / No

Fire Suppression Fluid Replaced: Yes / No

Fluids Changed:

Additional Service Information

Service Information

Odometer:

Technician Name:

Date:

Next Service Due:

Authorised Dealer Stamp

Service Advisor Name:

Service Advisor Signature:

Service Details

Service Actions Checked: Yes / No

Air Filter Changed: Yes / No

Pollen Filter Changed: Yes / No

Spark Plugs Changed: Yes / No

Fire Suppression Fluid Replaced: Yes / No

Fluids Changed:

Additional Service Information

Service Information

Odometer:

Technician Name:

Date:

Next Service Due:

Authorised Dealer Stamp

Service Advisor Name:

Service Advisor Signature:

Service Details

Service Actions Checked: Yes / No

Air Filter Changed: Yes / No

Pollen Filter Changed: Yes / No

Spark Plugs Changed: Yes / No

Fire Suppression Fluid Replaced: Yes / No

Fluids Changed:

Additional Service Information

Service Information

Odometer:

Technician Name:

Date:

Next Service Due:

Authorised Dealer Stamp

Service Advisor Name:

Service Advisor Signature:

Service Details

Service Actions Checked: Yes / No

Air Filter Changed: Yes / No

Pollen Filter Changed: Yes / No

Spark Plugs Changed: Yes / No

Fire Suppression Fluid Replaced: Yes / No

Fluids Changed:

Additional Service Information

Service Information

Odometer:

Technician Name:

Date:

Next Service Due:

Authorised Dealer Stamp

Service Advisor Name:

Service Advisor Signature:

Service Details

Service Actions Checked: Yes / No

Air Filter Changed: Yes / No

Pollen Filter Changed: Yes / No

Spark Plugs Changed: Yes / No

Fire Suppression Fluid Replaced: Yes / No

Fluids Changed:

Additional Service Information

Service Information

Odometer:

Technician Name:

Date:

Next Service Due:

Authorised Dealer Stamp

Service Advisor Name:

Service Advisor Signature:

Service Details

Service Actions Checked: Yes / No

Air Filter Changed: Yes / No

Pollen Filter Changed: Yes / No

Spark Plugs Changed: Yes / No

Fire Suppression Fluid Replaced: Yes / No

Fluids Changed:

Additional Service Information

Service Information

Odometer:

Technician Name:

Date:

Next Service Due:

Authorised Dealer Stamp

Service Advisor Name:

Service Advisor Signature:

Service Details

Service Actions Checked: Yes / No

Air Filter Changed: Yes / No

Pollen Filter Changed: Yes / No

Spark Plugs Changed: Yes / No

Fire Suppression Fluid Replaced: Yes / No

Fluids Changed:

Additional Service Information

Service Information

Odometer:

Technician Name:

Date:

Next Service Due:

Authorised Dealer Stamp

Service Advisor Name:

Service Advisor Signature:

Service Details

Service Actions Checked: Yes / No

Air Filter Changed: Yes / No

Pollen Filter Changed: Yes / No

Spark Plugs Changed: Yes / No

Fire Suppression Fluid Replaced: Yes / No

Fluids Changed:

Additional Service Information

Service Information

Odometer:

Technician Name:

Date:

Next Service Due:

Authorised Dealer Stamp

Service Advisor Name:

Service Advisor Signature:

Service Details

Service Actions Checked: Yes / No

Air Filter Changed: Yes / No

Pollen Filter Changed: Yes / No

Spark Plugs Changed: Yes / No

Fire Suppression Fluid Replaced: Yes / No

Fluids Changed:

Additional Service Information

Service Information

Odometer:

Technician Name:

Date:

Next Service Due:

Authorised Dealer Stamp

Service Advisor Name:

Service Advisor Signature:

Service Details

Service Actions Checked: Yes / No

Air Filter Changed: Yes / No

Pollen Filter Changed: Yes / No

Spark Plugs Changed: Yes / No

Fire Suppression Fluid Replaced: Yes / No

Fluids Changed:

Additional Service Information

Service Information

Odometer:

Technician Name:

Date:

Next Service Due:

Authorised Dealer Stamp

Service Advisor Name:

Service Advisor Signature:

Service Details

Service Actions Checked: Yes / No

Air Filter Changed: Yes / No

Pollen Filter Changed: Yes / No

Spark Plugs Changed: Yes / No

Fire Suppression Fluid Replaced: Yes / No

Fluids Changed:

Additional Service Information

Service Information

Odometer:

Technician Name:

Date:

Next Service Due:

Authorised Dealer Stamp

Service Advisor Name:

Service Advisor Signature:

Service Details

Service Actions Checked: Yes / No

Air Filter Changed: Yes / No

Pollen Filter Changed: Yes / No

Spark Plugs Changed: Yes / No

Fire Suppression Fluid Replaced: Yes / No

Fluids Changed:

Additional Service Information

Service Information

Odometer:

Technician Name:

Date:

Next Service Due:

Authorised Dealer Stamp

Service Advisor Name:

Service Advisor Signature:

Service Details

Service Actions Checked: Yes / No

Air Filter Changed: Yes / No

Pollen Filter Changed: Yes / No

Spark Plugs Changed: Yes / No

Fire Suppression Fluid Replaced: Yes / No

Fluids Changed:

Additional Service Information

Service Information

Odometer:

Technician Name:

Date:

Next Service Due:

Authorised Dealer Stamp

Service Advisor Name:

Service Advisor Signature:

Service Details

Service Actions Checked: Yes / No

Air Filter Changed: Yes / No

Pollen Filter Changed: Yes / No

Spark Plugs Changed: Yes / No

Fire Suppression Fluid Replaced: Yes / No

Fluids Changed:

Additional Service Information

Brake Disc Check

At each brake pad change (per axle), the ceramic brake discs are required to be cleaned, dried and weighed. Record the date of each brake pad change and disc weight.

Brake Pads Changed - Brake Discs Checked

Disc Weight (Front Axle):	kg	kg
---------------------------	----	----

Disc Weight (Rear Axle):	kg	kg
--------------------------	----	----

Odometer:

Signature:	Date:
------------	-------

Brake Pads Changed - Brake Discs Checked

Disc Weight (Front Axle):	kg	kg
---------------------------	----	----

Disc Weight (Rear Axle):	kg	kg
--------------------------	----	----

Odometer:

Signature:	Date:
------------	-------

Brake Pads Changed - Brake Discs Checked

Disc Weight (Front Axle): kg kg

Disc Weight (Rear Axle): kg kg

Odometer:

Signature: Date:

Brake Pads Changed - Brake Discs Checked

Disc Weight (Front Axle): kg kg

Disc Weight (Rear Axle): kg kg

Odometer:

Signature: Date:

Brake Pads Changed - Brake Discs Checked

Disc Weight (Front Axle): kg kg

Disc Weight (Rear Axle): kg kg

Odometer:

Signature: Date:

Brake Pads Changed - Brake Discs Checked

Disc Weight (Front Axle): kg kg

Disc Weight (Rear Axle): kg kg

Odometer:

Signature: Date:

Brake Pads Changed - Brake Discs Checked

Disc Weight (Front Axle): kg kg

Disc Weight (Rear Axle): kg kg

Odometer:

Signature: Date:

Brake Pads Changed - Brake Discs Checked

Disc Weight (Front Axle): kg kg

Disc Weight (Rear Axle): kg kg

Odometer:

Signature: Date:

Brake Pads Changed - Brake Discs Checked

Disc Weight (Front Axle): kg kg

Disc Weight (Rear Axle): kg kg

Odometer:

Signature: Date:

Brake Pads Changed - Brake Discs Checked

Disc Weight (Front Axle): kg kg

Disc Weight (Rear Axle): kg kg

Odometer:

Signature: Date:

Field Service Actions

Action No.	Date	Dealer

Action No.	Date	Dealer

Service Action Recalls

Action No.	Date	Dealer	Recall No.	Date	Dealer

Aston Martin Warranty

1 Valkyrie Warranty.....	B.2
2 Anti Perforation Corrosion Protection Warranty	B.4
3 Warranty Period.....	B.5
4 Who May Repair the Vehicle.....	B.5
5 Wear and Tear Items	B.6
6 What is Not Covered	B.7
7 Customer Responsibility	B.10
Warranty Coverage when Touring	B.11
Consumer Law	B.11
Owner And Vehicle Details	B.12

1 Valkyrie Warranty

Aston Martin gives a Warranty for each new Valkyrie vehicle and each replacement vehicle or assembly manufactured or supplied by the Company to be free from defects in material and workmanship under normal use and service for the applicable Warranty period.

The warranties provided herein are for the benefit of the original purchaser and any subsequent owner during the relevant Warranty Period (defined below) in the Serviced Countries (defined below).

An Aston Martin vehicle is built and homologated to support the Region for which it is manufactured and is compliant with the local regulatory requirements of that Region. As a result, the warranties cover Aston Martin vehicles that are built for and supplied to the Region.

 *Warranty is only valid for region the vehicle is built for. If the vehicle is imported or exported to another region the warranty will no longer be valid.*

For the purposes of this Owner's Guide, Region means one of the following territories:

- The Americas; or
- United Kingdom, Europe, Russia, Ukraine and South Africa; or
- Middle East, North Africa, and Turkey; or
- Asia Pacific; or
- China; or
- Any other market that does not have an authorised Aston Martin Dealer

'Serviced Countries' means either: (a) any country in the Region from which your Aston Martin vehicle was purchased, where there is an authorised Aston Martin Dealer; or (b) any country agreed in writing with Aston Martin.

 *Tyres are covered separately by the tyre manufacturer. Dealers are expected to offer assistance to the customer in pursuing a claim against the tyre manufacturer.*

1.1 Warranty limitations

The Warranty is the only express Warranty applicable to your Vehicle. Aston Martin neither assumes, nor authorizes anyone to assume for it, any other obligation or liability in connection with the Warranty. No person, including Aston Martin employees or Valkyrie Service Centres, may modify or waive any part of the Warranty.

1 a) Limitation of Remedies

Under the Warranty, it is agreed that the sole exclusive remedy against Aston Martin and its authorised Dealers shall be for the repair or replacement of defective parts as provided herein. The sole purpose of this exclusive remedy shall be to provide for the free repair and replacement of defective parts in the manner prescribed in this Warranty.

This exclusive remedy shall not be deemed to have failed its essential purpose so long as Aston Martin, through its authorised Dealers, is willing and able to repair or replace defective parts in the prescribed manner.

Aston Martin and its authorised Dealers are not responsible to the Owner for any losses, damages, costs or charges arising directly or indirectly from: (i) any inconvenience or delay of work carried out under the Warranty; (ii) any loss of transportation or use of the Vehicle; (iii) the use of rental vehicles, fuel, telephone, travel, meals or lodging; (iv) any loss of personal or commercial property; (v) any loss of revenue; and/ or (vi) any other incidental or consequential damages that may be incurred or suffered.

Punitive, exemplary, or multiple damages may not be recovered unless applicable law prohibits their disclaimer. The Owner shall not bring any warranty-related claim as a class representative, a private attorney general, a member of a class of claimants or in any other representative capacity. Aston Martin shall not be liable for any damages caused by delay in delivery or furnishing of any products and/or services.

1 b) Implied Warranties and Consequential Damages

Under the law of some jurisdictions, the Owner may be entitled to the benefit of the implied warranties of merchantability or fitness for intended purpose. These implied warranties are limited to the extent allowed by law to the time period covered by the written warranties, or the applicable time period provided by law, whichever period is shorter.

Some jurisdictions do not permit a limitation on how long an implied warranty will last, or on the exclusion or limitation of incidental or consequential damages, so the above limitation may not apply. The Warranty gives owners specific legal rights, and they may also have other rights that vary between jurisdictions.

2 Anti Perforation Corrosion Protection Warranty

1.2 Warranty Statement

Aston Martin warrants that during the Warranty period, if a Vehicle is properly operated and maintained by the user in accordance with the Maintenance section of the Owner's Guide, repairs required to correct defects in materials or workmanship will be performed without charge; any component covered by the Warranty found to be defective in materials or workmanship will be repaired, or replaced, without charge. Aston Martin Dealers will repair the Vehicle with genuine approved Aston Martin parts.

1.3 Warranty Coverage

The Warranty covers any original or OEM component of the Vehicle that is defective during the basic Warranty period, with the exception of tyres, the items listed under paragraph 6.4, normal maintenance items and regularly scheduled maintenance parts and labour. The Warranty includes any part scheduled for routine replacement during the Warranty period only if it is defective. If a part fails at the same time it is due for replacement it is not covered by the Warranty.

1.4 Exchange Parts Under Warranty

New parts will only be used for repairs at PDI and during the first month or 1000 Km (600 miles) (which ever occurs first) from the date the vehicle is handed over to the first retail customer. Thereafter exchange parts must be used where available under Aston Martin's exchange plan. The Valkyrie Service Centre or nominated dealer carrying out the warranty repairs will be familiar with such plan.

The Vehicle's bodywork is protected by an Anti Perforation Corrosion Warranty. Should any part of the bodywork of the Vehicle suffer from anti- perforation corrosion during the applicable warranty period, the panel(s) affected by the perforation will be repaired or replaced.

The term 'perforation' means a hole that is caused by corrosion that penetrates from the inner surface of a body panel or box section outwards.

3 Warranty Period

The period of cover for all types of warranty commences on the day the vehicle is handed over to the first registered keeper of the car.

The Vehicle Warranty period of cover is three years with unlimited mileage.

The Anti-Perforation Corrosion Warranty period of cover is ten years with unlimited mileage.

4 Who May Repair the Vehicle

Specialist Valkyrie Service Centres will be appointed by and receive full technical support from Aston Martin. The Valkyrie Service Centres will provide support and facilities for the servicing and repair of the Vehicle. Only these specialist Valkyrie Service Centres will, under the terms of this Warranty, repair or replace, free of charge to the Owner, any part or assembly proved to Aston Martin's satisfaction to show a defect in materials or workmanship within the applicable period. Additionally, nominated Aston Martin Dealers may be appointed by Aston Martin to supplement the Valkyrie Service Centre network.

5 Wear and Tear Items

Items that are subject to wear and tear are generally divided into two categories, namely those specified for replacement or adjustment during scheduled maintenance and those that require replacement or adjustment dependent upon conditions of use.

5.1 Scheduled Maintenance Items

The items listed below are covered by the Vehicle Warranty up to the first scheduled change point that replacement or adjustment is required during scheduled maintenance operations. The service chapter sets out such scheduled maintenance operations (Refer to 'Servicing', page A.5).

- Spark plugs
- Oil, air, pollen and fuel filters.

 *The period of warranty cover for any item may not exceed the time and distance limitation of the vehicle warranty.*

5.2 Wear and Tear Items

The items listed below are recognised as having a limited service life or are subject to wear or damage. However, these items are covered by the vehicle warranty for up to one year or 5,000 km (3,100 miles), which ever occurs first.

- Wiper blades.
- Wheel alignment and balancing.
- Under vehicle body panels.
- Adjustments, including but not limited to: headlamp and hinged panel adjustments, suspension tightening, steering geometry adjustments, emission and fuel systems checks.
- Vehicle key batteries.

 *Brake pads, brake discs and other friction related components are not covered when replacement is due to wear and tear, but they are covered against manufacturing defects (whether in material or workmanship) for the duration of the Vehicle Warranty.*

5.3 Consumables

Replacement or top up of consumable fluids, e.g. oils, antifreeze, brake fluid, windscreen wash solution and refrigerant, will only be covered when they are used as part of a warranty repair.

6 What is Not Covered

Aston Martin is **not** responsible for any repair or replacement that is required as a direct result of:

- Normal wear and tear.
- Friction related components, e.g. brake pads and brake discs.
- Failure to properly maintain the vehicle in accordance with Aston Martin's maintenance schedules and service instructions.
- Failure to use Aston Martin specified parts or fluids during a warranty repair (or parts of equivalent quality during a retail repair).
- Damage resulting from neglect, accident, flooding or improper use.

6.1 Damage Caused by Accident, Alteration or Misuse

The warranty does not cover:

- Damage caused by collision, fire, flood, theft, freezing, vandalism, riot, explosion, or objects striking the Vehicle .
- Misuse of the Vehicle, such as driving over curbs, overloading, or using the Vehicle as a stationary power source.
- Defects caused as a result of the vehicle being used in motor sport or track events (other than events organised by Aston Martin) or for any other purpose other than normal private use.
- Any modification of the vehicle or parts which is not authorised by Aston Martin, including any engine performance enhancement modifications.
- Any vehicle that has had its vehicle identification number altered or removed, or on which the odometer reading has been unlawfully altered.
- Use of contaminated or improper fuel or fluids or application of unauthorized chemicals by the customer.

6.2 Damage Caused by Use or The Environment

Surface rust, deterioration and damage of paint, trim, upholstery and other appearance items that result from use and/or exposure to the elements are not covered under the Warranty.

The Warranty does not cover:

- Stone chips, scratches.
- Lightning, hail damage.
- Dints or dents.
- Windstorm damage.
- Road salt, tree sap.
- Earthquake damage.
- Bird and insect droppings.
- Freezing, water or flood damage.
- Cuts, burns, punctures or tears.
- Windshield stress cracks.
- Rodent damage.
- Improper polishing of paint surface.

6.3 Damage Cause by Failure to Maintain or Improper Maintenance

Damage caused by failure to maintain the Vehicle, improper maintenance of the Vehicle, or using the wrong fuel, oil, lubricants, or fluids is not covered under the Warranty. Please refer to the Maintenance section of the Owner's Guide for correct fluid levels, and for information on the proper ways to maintain the Vehicle.

Examples of important maintenance procedures that must be carried out correctly are:

- Oil changes.
- Cleaning and polishing.
- Oils, lubricants and other fluids.
- Engine tune-up.
- Oil and air filters.
- Wiper blades.
- Brake pads and lining.
- Tyre rotation / inflation.
- Clutch linings.
- Wheel alignments and tyre balancing.
- Refilling or topping up with incorrect fuel, e.g. diesel instead of petrol.
- Use of bio ethanol alternative fuels.
- Use of a fuel not approved or recommended by Aston Martin in the Owner's Guide is considered mis-fuelling, and that any damage resulting from mis-fuelling is not covered by the vehicle warranty.

6.4 Other Items and Conditions Not Covered by the Warranty

The Warranty does not cover:

- Any component designated as part of the Valkyrie Track Pack.
 - The installation or use of a non-Aston Martin part (other than a certified emissions part) or any part (Aston Martin or non-Aston Martin) designed for off-road use only installed after the vehicle leaves the control of Aston Martin, if the installed part fails or causes an Aston Martin part to fail.
 - Damage to, or caused by, non-approved snow traction devices or towing devices.
 - Damage caused by failure to maintain adequate levels of fuel in your vehicle.
 - Vehicles that have been labelled or branded as being 'dismantled', 'fire', 'flood', 'junk', 'rebuilt', 'reconstructed', 'salvaged' – this will void the Warranties.
 - Vehicles that have been determined as a 'total loss' by an insurance company, or other official body –this will void the Warranties.
 - Service adjustments, wear items and alignments after one (1) year or 5,000 km (3,100 miles), whichever occurs first.
 - Use of alternative fuels: Aston Martin does not recommend or approve of the use of Liquid Petroleum gas or Compressed Natural gas. Damage caused by the use of alternative fuels or fuel additives is not covered by the vehicle Warranty.
- Normal wear or worn out tyres. Tyres will not be replaced (unless required by a warranty repair) for wear or damage including a) tyre damage from road hazard such as cuts, snags, bruises, bulges, puncture, and impact breaks; and b) tyre damage due to under or over inflation, tyre chain use, racing, spinning (including when stuck in snow or mud), improper mounting or dismounting, or tyre repair.
 - Vehicles that have had the odometer disconnected, altered, or inoperative for an extended period of time with the result that the actual mileage cannot be determined.

6.5 Paint Surface and Corrosion Protection

Aston Martin is not responsible for any repair or replacement that is required as a direct result of the following:

- Failure to properly maintain paint and bodywork by regular cleaning in accordance with Aston Martin instructions.
- Factors beyond Aston Martin's control, such as environmental hazards (including industrial fallout, storm damage, acid rain) and damage (including stone chips, scratches and use of unsuitable cleaning agents).
- Accident repairs using materials or methods of repair that have not been approved by Aston Martin.
- Alterations of the vehicle from Aston Martin's original specification.
- Failure to rectify on a timely basis any paint or corrosion damage as recorded in the vehicle documentation by the Valkyrie service centre at the time of the annual inspection.

6.6 Other Exclusions

The Aston Martin warranty excludes liability for any lost time, inconvenience, loss of transportation, or any other incidental or consequential damage you (or anyone else) may incur as a result of a defect covered by this warranty.

This handbook describes the proper care and use of the vehicle. Proper maintenance and use guard against major repair expenses resulting from misuse, neglect or inadequate maintenance, and may help increase the value that the customer may receive when selling the vehicle.

The Customer is responsible to:

- Make sure that the vehicle is maintained in accordance with the vehicle service and maintenance guide published in the customer literature.
Failure to perform maintenance promptly and in accordance with Aston Martin's specified service intervals will invalidate warranty coverage on the parts affected.
- The customer is required to take the vehicle to an Aston Martin Dealer or Valkyrie Service Centre for any warranty repairs as soon as practicable after a defect is detected.
- Make sure that the Service and Maintenance schedule has been stamped by the servicing dealer after the completion of a scheduled service operation.
- Make sure that paint and bodywork is maintained by regular cleaning in accordance with the vehicle manufacturer's instructions.
- Make sure that the body panels are examined annually by an authorised Aston Martin Dealer and that this inspection is recorded in the Owner's Handbook.

Warranty Coverage when Touring

Aston Martin has a comprehensive service network in most parts of the world. An Aston Martin Dealer will carry out repairs under the terms of the vehicle warranty where possible, but due to the complex nature of this vehicle, work may need to be completed at a dedicated Valkyrie Service Centre. If such work is required your Aston Martin Dealer will arrange for your vehicle to be transported to a Valkyrie Service Centre, providing the vehicle is in the Region of original sale. Under normal circumstances, the customer should not be required to pay for any warranty work performed by an Aston Martin Dealer or Valkyrie Service Centre. It is the customer's responsibility to produce the warranty documentation issued with the new vehicle. This establishes the customer's right to warranty coverage and the relevant maintenance and service records. If the customer is unable to do so, the Dealer should seek advice from Aston Martin.

Consumer Law

The Warranty is a manufacturer's warranty that supplements and does not affect the Owner's legal rights under the vehicle purchase agreement or under applicable national legislation governing the sale of consumer goods.

Owner And Vehicle Details

Name:

Registration Plate No.:

Address:

VIN No.:

:

Engine No.:

:

Warranty Start Date:

:

Post Code:

If the vehicle is sold, the benefits of any un-expired portion of the warranties can be transferred to the new owner.

The new owner should complete a 'tear off' sheet (next page) and send the new details to:

Aston Martin Warranty Department

Aston Martin Lagonda Limited

Banbury Road

Gaydon

Warwick

CV35 0DB

England

Signature:

Date:

Dealer Stamp

Owner Warranty Transfer (2)

VIN No.:

Odometer:

Date of Purchase:

Name:

Address:

:

:

Post Code:

Telephone No.:

Email Address:

Signature:

Date:

Owner Warranty Transfer (1)

VIN No.:

Odometer:

Date of Purchase:

Name:

Address:

:

:

Post Code:

Telephone No.:

Email Address:

Signature:

Date:



ASTON MARTIN



ASTON MARTIN

Owner Warranty Transfer (4)

VIN No.:

Odometer:

Date of Purchase:

Name:

Address:

:

:

Post Code:

Telephone No.:

Email Address:

Signature:

Date:

Owner Warranty Transfer (3)

VIN No.:

Odometer:

Date of Purchase:

Name:

Address:

:

:

Post Code:

Telephone No.:

Email Address:

Signature:

Date:



ASTON MARTIN



ASTON MARTIN

Owner Warranty Transfer (6)

VIN No.:

Odometer:

Date of Purchase:

Name:

Address:

:

:

Post Code:

Telephone No.:

Email Address:

Signature:

Date:

Owner Warranty Transfer (5)

VIN No.:

Odometer:

Date of Purchase:

Name:

Address:

:

:

Post Code:

Telephone No.:

Email Address:

Signature:

Date:



ASTON MARTIN



ASTON MARTIN

Aston Martin Assistance

Emergency Assistance	C.2
Benefits	C.3
Alternative Travel Arrangements	C.5
What To Do In An Emergency	C.7
European Autoroute Restrictions.....	C.8
What is not Covered	C.9
Schedule - Eligible Vehicles	C.13

Emergency Assistance

As the owner of an Aston Martin vehicle you should enjoy a high standard of trouble free motoring. However, should the unexpected occur, our worldwide Dealer network is there to help you. Details and contact telephone numbers are shown in the Dealer Directory. In the UK and specific countries within Europe, a special additional emergency service, known as '**Aston Martin Emergency Assistance**', has been designed to provide you and your passengers with the help you need quickly and efficiently should your vehicle suffer a Breakdown Incident ¹.

Vehicles Covered

The benefits of Aston Martin Emergency Assistance are applicable to new and approved pre-owned Aston Martin vehicles purchased from an authorised Aston Martin Dealer. Refer to www.astonmartin.com for a list of all authorised Aston Martin Dealers.

At completion of your purchase, your Aston Martin Dealer will register your vehicle for Aston Martin Emergency Assistance. From registration, your vehicle will be entitled to Aston Martin Emergency Assistance (the '**Vehicle**'). For more details of what constitutes an eligible Vehicle, and term of cover, please refer to the Schedule.

Owners of eligible Vehicles can also obtain Aston Martin Emergency Assistance when travelling temporarily outside their Country ², within Europe.

¹. A **Breakdown Incident** means an event where an eligible Vehicle is immobilised due to a breakdown in circumstances where it qualifies for Aston Martin Emergency Assistance, including home-starts or broken glass. Furthermore, Aston Martin Emergency Assistance covers you in the event of safety-related defects, which render the Vehicle illegal to drive. These defects relate to, for example, failure of the seat belts, windscreen wipers, direction indicators, front and rear lamps.

². '**Country**' means the country in which your Vehicle is registered.

Benefits

Europe is defined as:

Andorra, Austria, Belgium, Bosnia- Herzegovina, Bulgaria, Crete, Croatia, Czech Republic, Denmark, Estonia, Finland, France, Germany, Gibraltar, Greece, Hungary, Italy, Latvia, Liechtenstein, Lithuania, Luxembourg, Malta, Monaco, Morocco, Netherlands, Norway, Poland, Portugal (not Madeira), Republic of Ireland, Romania, Russia, San Marino, Slovakia, Slovenia, Spain (including the Balearic and Canary Islands), Sweden, Switzerland, Turkey (European part), Ukraine, and Vatican City (Rome);.

United Kingdom (UK) is defined as:

England, Scotland, Wales, Northern Ireland, Channel Islands and Isle of Man.

The service provider, appointed by Aston Martin to provide the Aston Martin Emergency Assistance services (the 'Service Provider') will provide the following benefits dependent on requirements to entitled Vehicles in both the home Country and Europe as defined.

Roadside Assistance

The Service Provider's Agent vehicle should promptly arrive with you after your call has been placed. You may also book an appointment for a convenient time.

Aston Martin Emergency Assistance shall provide you with updates on its estimated time of arrival via your preferred communication method.

If following a Breakdown Incident in an area of coverage, your journey cannot be completed, and where the Vehicle cannot be repaired at the roadside, Aston Martin Emergency Assistance shall organise recovery of the Vehicle, including any luggage contained in the Vehicle at the time. Your Vehicle and luggage shall be transported to the nearest Aston Martin Dealer, without distance or financial limitation.

If the Vehicle cannot be repaired at the roadside or at your home address within a reasonable time period (45 minutes), the Service Provider will take you, the Vehicle and your passengers to the nearest Aston Martin Dealer. In the event that you (or your passengers) need to keep an important appointment, you will be taken there before the disabled Vehicle is transported to its required destination.

The Aston Martin Valkyrie is a high performance vehicle orientated towards track usage. As such it has very limited ground clearance, and may require transportation by a specialist recovery vehicle. In the event that such a recovery vehicle is not available in an acceptable time frame, Aston Martin Emergency Assistance will wait with your vehicle, while you and your passengers take alternative onward transport. See Alternative Travel Arrangements.

Should the Breakdown Incident occur outside of workshop hours, Aston Martin Emergency Assistance shall arrange for secure storage of the Vehicle until the next working day. The Vehicle shall arrive at the Dealer by midday on the next day. If the nearest Dealer, to where the eligible Vehicle has been towed, is able to carry out the repairs at its premises, then the Vehicle will be repaired there.

Once the Vehicle is at a Dealership for repair, Aston Martin Emergency Assistance will keep in contact with the Dealer to follow the progress of the repair, and if necessary, arrange any extension of a replacement vehicle with Aston Martin Customer Service.

Home Start

Aston Martin Emergency Assistance will provide all the benefits of Roadside Assistance at the Vehicle's registered address.

Recovery

If Aston Martin Emergency Assistance cannot repair your Vehicle at the roadside, the Service Provider will arrange recovery of you and your Vehicle to the nearest Aston Martin Dealer.

If your Vehicle has been involved in an accident or has gone off the road and needs to be salvaged before towing, Aston Martin Emergency Assistance will charge you for services on a 'Pay for Use' basis and you may be able to claim these back from your insurance company.

You will be covered for costs of recovery and towing (including any handling fee) but you may be charged for any costs incurred if the Vehicle is, for example, disabled by floods or snow-affected roads, is embedded in sand or mud, or is not easily accessible.

If your Vehicle cannot be repaired and / or recovery is initiated to an Aston Martin Dealer, the Service Provider will provide alternative travel options for you. You will be entitled to receive one of the following additional services:

- An alternative replacement vehicle for up to two working days in your Country, or 14 days if the Breakdown Incident occurs outside your Country (a collection and delivery service, or equivalent, is available from chosen suppliers subject to availability and supplier's terms and conditions);
- Onward transportation;
- Overnight accommodation.

Vehicle Collection Following Repair

Following repairs organised by Aston Martin, the cost of a first class rail ticket or (if rail transport would normally exceed six hours) a business class air ticket will be met to permit you or a person you designate to collect the repaired Vehicle. Alternatively, arrangements can be made for your Vehicle to be returned to your home or business address, whichever is the nearest to the repairing Dealer. Alternative addresses closer to the repairing Dealer may also be considered.

Alternative Travel Arrangements

If the Service Provider estimates that the repairs to your Vehicle will take more than eight hours, the Aston Martin Emergency Assistance will cover your reasonable costs for alternative necessary travel, including for members of your party.

Reasonable additional expenses shall be covered for one or a combination of the following:

- Alternative replacement vehicle costs to a maximum of two working days in your Country and up to 14 days outside your Country.
- Air fares (business class ticket).
- Rail fares (first class ticket).
- Local taxi fares.
- Any other transport equivalent to first class rail fares.

Onward or Home Journey

If following a Breakdown Incident that occurs more than 80 km (50 miles) from your place of residence, your Vehicle cannot be repaired at the roadside on the same day of the Breakdown Incident, Aston Martin Emergency Assistance will cover:

- The costs of the journey from the place of the Breakdown Incident to the nearest Dealer.
- The costs of a replacement vehicle as outlined above.
- Where necessary, taxi costs for one journey to the nearest accessible train station or airport, for you and your passenger(s).
- Where necessary, the costs of a first class train journey for you and your passenger(s). If the train journey exceeds six hours, the cost of a scheduled flight (Business Class) for you and your passenger(s).

Aston Martin Emergency Assistance will reimburse you for reasonable costs incurred relating to the above, upon receipt of a claim letter from you, detailing the circumstances of the claim, along with receipts for all transport costs claimed. All claim letters must be directed to Aston Martin Emergency Assistance at Aston Martin Customer Service, Aston Martin Lagonda Limited, Banbury Road, Gaydon, Warwick, CV35 0DB. Only costs directly connected with the Breakdown Incident will be covered.

The refund process to you shall be managed by Aston Martin Emergency Assistance.

Repaired Vehicle Re-delivery

Aston Martin will attempt to contact you within 24 hours of successful repair at the Dealer in order to arrange re-delivery of the repaired Vehicle to either your home or place of work, as you request. Alternative addresses closer to the Repairing Dealer may also be considered.

Hotel

If following a Breakdown Incident that occurs more than 80 km/ 50 miles from your place of residence, and your Vehicle cannot be repaired at the roadside on the day of the Breakdown Incident, accommodation costs for you and your passenger(s) shall be covered for the duration of the repair, for up to a maximum of two nights if the Breakdown Incident occurs in your Country, or seven nights if the Breakdown Incident occurs outside your Country. You shall be responsible for any excess costs.

What To Do In An Emergency

Repatriation of Un-repaired Vehicle from Abroad

If the Vehicle cannot be repaired by Aston Martin within an agreed time schedule (three working days), the costs for transporting the Vehicle and its contents from the Dealer to the home Country Dealer, will be covered by Aston Martin.

Aston Martin shall arrange the safe repatriation of the Vehicle at the least cost, while respecting the need to deliver the Vehicle to the home Dealer within 14 consecutive days.

Aston Martin will cover the costs for parking the Vehicle, pending repatriation or import.

Should assistance be required in the unlikely event of a Breakdown Incident, simply contact Aston Martin Emergency Assistance using the relevant telephone number listed below.

 *It may be helpful to have the relevant telephone numbers entered into your mobile phone 'phone book'.*

00 800 28 86 28 86 ¹

+44 208 603 9875

When connected, enter the 2 digit number as prompted for your home country. Please do not make your own arrangements as Aston Martin Emergency Assistance will be not be able to reimburse you. If you are in a remote location and need assistance, the time taken to receive the assistance may be longer because of distance and local restrictions.

¹. Calls from landlines shall be free. Calls from mobile phones will be charged at standard mobile network rates.

European Autoroute Restrictions

Vehicle Identification and Location

To minimise delay, please have the following information available:

- Your name.
- Aston Martin model.
- The Vehicle Identification Number (VIN). The last six digits from the VIN label in the corner of the windscreen.
- The location of the vehicle.
- Vehicle registration number and colour.
- Telephone number where you can be contacted.
- Description of the concern experienced.

If assistance is required on a French Autoroute or on certain Autoroutes in other European countries, you must use the official SOS boxes at the side of the road in order to arrange initial assistance or recovery. You will be connected to the authorised Autoroute Assistance Service because these roads are privatised. Neither Aston Martin Emergency Assistance nor any other assistance organisations are allowed to assist on these roads.

Once your Aston Martin has been recovered from the Autoroute, you should contact Aston Martin Emergency Assistance at the earliest opportunity to make sure that any further assistance arrangements you require can be made on your behalf.

Aston Martin Emergency Assistance will advise you how to reclaim costs incurred for recovery from the Autoroute.

What is not Covered

Aston Martin Emergency Assistance is thorough and comprehensive; however, claims cannot be met as a result of any of the following:

1. Where you, or anyone else acting on your behalf, make repair or service arrangements without authorisation (and a file number) from Aston Martin Emergency Assistance.
2. Where any loss, theft, damage, death, bodily injury, cost or expense that is not directly associated with the incident that caused you to claim, unless expressly stated in this policy.
3. If the Breakdown Incident is due to fire, theft, accident or vandalism, your costs will not be covered by Aston Martin Emergency Assistance but should be met by third party insurance covering the incident.
4. Damage or injury intentionally caused by you or resulting from your participation in a criminal offence.
5. If your Vehicle is kept in an un-roadworthy condition or has not been serviced in accordance with the Manufacturer's recommendations.
6. Any costs that would have been payable by you, such as petrol, toll charges, parking fees, cost of meals, drinks, telephone calls and/ or newspapers or any other costs not specifically stated as being covered by Aston Martin Emergency Assistance, which may be incurred by you and/ or the other member(s) of your party as a result of and/ or in connection with the Breakdown Incident.
7. Release fees: Should your Vehicle be stolen and subsequently recovered by the police, you may be asked to pay a release fee before we can remove your Vehicle to an authorised Aston Martin Dealer.
8. Specialist charges: In the event that the use of specialist equipment is required to give assistance when your Vehicle has, for example, gone off the road, is in a ditch, is standing on soft ground, sand, shingle, stuck in water or snow or has been immobilised by the removal of its wheels, we will arrange recovery but you will be responsible for the costs of any specialist equipment required. The costs may be refundable under the terms of your motor insurance policy.
9. Adverse weather conditions: On those occasions when we experience adverse weather conditions, such as high winds, snow, floods, etc., external resources may be stretched and some operations become physically impossible until the weather improves. At such times, our priority is to make sure that you and your passengers are taken to a place of safety and so the recovery of your Vehicle may not be possible until weather conditions permit.

10. Customer induced breakdown incidents are not covered under Aston Martin Emergency Assistance. However, Aston Martin and the Service Provider will, at their sole discretion, assist you if you request it. However we are not obligated to provide assistance and you shall be responsible for any charges resulting from any assistance given caused by a customer induced fault. In such circumstances, a swipe card deposit may be taken by the Service Provider. Assistance in such circumstances will not include additional benefits (replacement vehicle, onward journey, hotel accommodation).

Customer induced faults may include, for example, the following:

- Lock-outs / lost keys
- Broken keys
- Discharged battery
- Running out or loss of fuel
- Use of wrong fuel (no replacement at the location of breakdown, only towing)
- Tyre damage
- Road traffic accidents.

11. Lockout / lost keys: Whilst we will always try to provide assistance by the most practical method, should you be unable to gain entry to your Vehicle, modern security systems make it extremely difficult for this to be done should spare keys not be available. If a forced entry is required, you will be asked to sign a declaration stating that you have given permission for this to take place and that any costs for resultant damage will be your sole responsibility.

12. Aston Martin Emergency Assistance shall not be required to provide services in the following circumstances:

- 12.1 In respect of eligible Vehicles situated on private property (for example garage premises) unless you can establish to the reasonable satisfaction of Aston Martin Emergency Assistance that permission has been given by the relevant owner or occupier.
- 12.2 Vehicle servicing or re-assembly where this is required as a result of neglect or unsuccessful work on the Vehicle other than on the part of the Service Provider or its agents.
- 12.3 The recovery of any Vehicles bearing trade plates or which Aston Martin Emergency Assistance has reason to believe have just been imported or purchased at auction.
- 12.4 The transportation of immobilised Vehicles where Aston Martin Emergency Assistance considers this to be part of a commercial activity.

-
- 12.5 Assistance for Vehicles broken down as a result of taking part in any 'Motor Sport Event', including, without limitation, motor racing, rallying, speed or duration tests or practice thereof, trials or time-trials, auto test (other than auto tests performed by the Client using roadworthy, road legal cars on public roads), but excluding 'Concours d'elegance' events, track test days for road-legal Vehicles or rallies held exclusively on open public roads where participants are required to comply with the normal rules of the road (save for Aston Martin organised and controlled track day events).
- 12.6 Where the police, highways agency and / or other emergency service require that your Vehicle be recovered by a third party.
- 12.7 Where your entitlement to Aston Martin Emergency Assistance lapses or if your Vehicle is no longer considered eligible for Aston Martin Roadside Assistance, the Service Provider may charge you directly for the Services provided. Any such charges will be charged on a 'pay for use' basis and will constitute a direct contract between you and the Service Provider. If it is determined that Aston Martin is at fault for the Vehicle not being recorded as an eligible Vehicle, then Aston Martin shall pay the relevant charges.
- 12.8 Assistance for routine maintenance and running repairs of the Vehicle such as fixing faulty radios and heated rear windows.
- 12.9 For transit risk insurance, which Aston Martin Emergency Assistance recommends you take out where a Vehicle is to be repatriated.
- 12.10 Where locksmiths, body-glass or tyre specialists are required. Aston Martin Emergency Assistance will endeavour to arrange for their assistance on your behalf, however, you will be responsible for the costs of their services. Further, if use of a locksmith or other specialist would, in Aston Martin Emergency Assistance's opinion, mobilise the vehicle, no further service will be given for the breakdown in question.
- 12.11 The transportation of any animal or pets shall be at the sole discretion of the Service Provider.

13. The Service Provider may charge you directly for:

- Any replacement component, lubricant and / or fuel (the 'Parts') or consumable items supplied (except where Aston Martin has provided or paid for such Parts)
- Any extension of the Services which you are entitled to receive in connection with this Agreement (which shall be performed by the Service Provider (in its absolute discretion) at your request.
- The use of any specialist lifting or towing assistance needed to recover your Vehicle if your Vehicle has gone off the road, is in a ditch, sunk in soft ground, sand or shingle or when it is stuck in snow or flood water.
- Any additional charges resulting from the failure to carry legal and serviceable spare wheel(s) or tyre(s) in the Vehicle. Aston Martin Emergency Assistance will endeavour to arrange assistance from a third party on your behalf but you will be responsible for the costs of the call out and/ or for any repair.
- The cost of garage or other labour required to repair the Vehicle, other than that provided by Aston Martin Emergency Assistance at the scene of the Breakdown Incident.
- Any costs of draining or removing fuel, lubricants or other fluids as a result of the introduction of an inappropriate substance.

- Transportation of personal effects, goods, vehicles, boats or other waterborne craft on or in the Vehicle and any trailer or caravan. Aston Martin Emergency Assistance will not consider any claim for loss resulting from damage to / loss of use of these items. Such items remain your responsibility at all times.

14. If following a Breakdown Incident, the Service Provider, its third party garage agent or subcontractor makes a temporary repair to your Vehicle (for these purposes, a temporary repair shall mean temporary repairs of the Vehicle where the underlying cause of the Vehicle's failure is not resolved), then the Service Provider, its third party garage agent or subcontractor shall recommend you to have such temporary repair made good by a Dealer.

Schedule - Eligible Vehicles

New Vehicles - 36 Months Cover

Any Aston Martin vehicle which is sold directly by Aston Martin or a Dealer in the UK or European Territories and which is first registered in the UK or European Territories (Refer to 'Emergency Assistance', page C.2).

Used Vehicles

(Cover may vary - consult with the selling Dealer)

Those used vehicles registered in the UK or the European Territories in respect of which an Extended Warranty has been started.

In All Cases

- Maximum Gross Vehicle Weight (including any caravans or trailers being towed at the time of the Breakdown Incident): 3500 Kg
- Maximum Vehicle Length: 5.5 m
- Maximum Vehicle Width: 2.3 m
- Maximum Vehicle Height: 3 m

The dimensions detailed above will be calculated taking into account anything attached to the relevant eligible Vehicle at the time of the relevant Breakdown Incident and any trailer or caravan, including but not limited to towing equipment, any carriers or racks (e.g. bike or luggage), or anything else attached to the Vehicle or the carriers / racks.

Vehicles must be built to manufacturer's specifications and, where applicable, hold a certificate of roadworthiness.



ASTON MARTIN



ASTON MARTIN

Alphabetical Index

A

Adjustment	
Pedals	1.7
Steering Column	1.6
Aston Martin Assistance	C.1
Aston Martin Facilities	A.2
Aston Martin Warranty	B.1

B

Battery Conditioner	6.25
Bluetooth	4.3
Bonnet Release	6.7
Brake Disc Check	A.30
Brakes	3.13
Brake Warnings	3.15
Footbrake	3.13
Park Brake	3.16

C

Cabin Features	1.6
Camera Monitoring System	1.7
Centre Controls	2.6
Centre Lock Wheels	6.39
Child Safety	1.18
Climate Control	
Automatic Climate Control	5.3
Manual Climate Control	5.4
Climate Controls	5.2
Coolant Levels	6.10

D

Data Telematics	E.3
Defrosting and Demisting	
Automatic	5.4
Doors	1.4
Drainage Holes	3.4
Driving Information	3.2

E

Ear Protection	1.16
Engine Oil Level	6.9
Engine Start	3.5
ERS Boost	3.18
ESP (Electronic Stability Program)	3.9
ESP Modes	3.10
Sport	3.10
Track	3.11
Urban	3.10

F

Fire Suppression System	1.17
Fluid Capacities	6.13
Fluid Specifications	6.12
Fluids and Capacities	6.8
Front License Plate Plinth	6.34
Fuel	6.43
Fuses	6.18
Cabin Fuse Box	6.21
Engine Fuse Box	6.19

H

Handling Modes	3.8
Sport	3.8
Track	3.9
Urban	3.8
Harness Replacement	6.3
Hazard Lamps	2.8
Headsets	4.15
High Voltage Systems	1.11
HVIL	1.14
Safety	1.12

I

Infotainment Menu	4.2
Instrument Cluster	
Display	2.3
Warning Symbols	2.4

K

Key Battery Replacement	1.2
-------------------------------	-----

L

Lamps	6.26
Launch Control	3.18
Lighting	2.6
Exterior	2.6

M

Multimedia	4.5
------------------	-----

N

Navigation	4.9
------------------	-----

D.2 Alphabetical Index

O

Owner Maintenance Checks	6.5
--------------------------------	-----

P

Performance	6.32
Phone	4.11
Messages	4.12

S

Safety Harnesses	1.14
Safety Systems	1.14
Service Record	A.8
Servicing	A.5
Servicing Precautions	6.3
Settings Menu	4.14
Specifications	6.31
Body	6.13
Brakes	6.14
Engine	6.31
Steering	6.13
Suspension	6.13
Transmission	6.31
Steering Wheel	
Controls	2.2
Installation	1.6
Lamp Controls	2.7
Suspension Sweep	6.6

T

Track Days	3.3
Traction Control	3.12
Transmission Controls	3.7

Tyre Pressure Monitoring System (TPMS)	3.20
Tyre Repair Kit	6.41
Tyres	
Summer Tyres	6.17
Tyre Pressures	6.15
Winter Tyres	6.18

U

Unlocking and Opening	1.3
-----------------------------	-----

V

Vehicle Key	1.2
Battery	1.2
Vehicle Lifting	6.37
Vehicle Menu	4.13
Vehicle Provenance	A.3
Vehicle Push Points	6.37
Vehicle Recovery	6.35



ASTON MARTIN



ASTON MARTIN