



11/7/2023

Mr. Tristin Rojeck
Vehicle Programs and Compliance Division
Environmental Protection Agency
2000 Traverwood,
Ann Arbor, MI 48105

Subject: Request for issuance of a new Certificate of Conformity - initial application

Tesla, Inc. requests that the EPA issue a Certificate of Conformity for the subject test group.

Attached to this request is the Part 1 Application. Tesla believes that the test group complies with all applicable regulations contained within Title 40 of the CFR, California Amendments to Subparts B, C, and S, Part 86 and Part 88, Title 40 of the CFR and Title 13 of the California Code of Regulations

Vehicle Category:	Heavy Duty Vehicle (> 8500 lbs. GVW)
Durability Group:	RTSLEEVNNL3C
Test Group:	RTSLD00.0L3C
Summary Sheet No:	NA
Durability Group Description:	NA
Durability Vehicle:	NA
OBD Group:	NA
Test Group Description:	Tesla differentiates test groups based on: 1) battery type, 2) number of drive motors, and 3) vehicle line. L - Lithium Ion Battery 3 - Tri motors – performance version (front/rear (×2)) C - Cybertruck Line of vehicles
Applicable Standards:	FEDERAL Tier 3 BIN 0 & CALIFORNIA ZEV
Carlines Covered by this certificate:	Cybertruck Beast

Your early review and issuance of the certificate will be greatly appreciated. If you have any questions, please contact me at our office at (510) 249-3755

Sincerely,
Suraj Nagaraj

Sr. Director - Vehicle Homologation

Contents

01.00.00

01.01.00

01.01.01

01.01.02

03.00.00

03.01.00

03.02.00

03.03.00

03.04.00

04.00.00

05.00.00

06.00.00

06.01.00

06.02.00

06.03.00

07.00.00

07.01.00

07.02.00

07.03.00

07.04.00

08.00.00

08.01.00

08.02.00

08.03.00

08.03.01

08.03.02

08.03.03

08.03.04

08.03.05

08.04.00

08.05.00

08.06.00

08.06.01

08.06.02

08.06.03

08.06.04

08.07.00

08.07.01

08.07.02

08.08.00

08.08.01

08.08.02

08.09.00

08.10.00

08.11.00

08.11.01

08.12.00

08.13.00

09.00.00

10.00.00

11.00.00

Communications

Mailing information

Certification information

Responsible official

Facilities, Equipment and Test Procedures

Procedure to determine mass emissions of the fuel fired heater

Battery pre-conditioning procedures

Vehicle Configuration and sub-configurations

Test Procedures

Statement of Compliance

Reserved

Maintenance

Test vehicle scheduled maintenance

recommended customer maintenance schedule

Lubricants and heater fuels

Labels

Label locations

Sample emission control information label

California Environmental Performance Index label: 2015 and later model years

Projected sales information

General Technical Description

Description of propulsion system

Description of motor(s)

Description of batteries

Battery charging capacity

Self-discharge information

Description of thermal management system

Definition of end-of-life

Description of battery disposal plan

Description of controller / inverter

Description of transmission

Description of climate control system

Electric heat pump

Fuel-fired heater

Climate control system logic

Tamper resistance of climate control system that includes a fuel-fired heater

Description of regenerative braking system

Control logic

Percentage of braking performed on road by each axle

Description of charger

Proper recharging procedures

Power requirements necessary to recharge vehicle

Accessories which draw energy from the batteries

Other unique features (solar panels)

Description of warning system(s) for maintenance / malfunction

Cut-off terminal voltages for prevention of battery damage

Description of dyno mode

Description of coastdown mode

Reserved

Reserved

Starting and shifting schedules

11.01.00	Starting
11.02.00	Shifting
12.00.00	Reserved
13.00.00	Reserved
14.00.00	Reserved
15.00.00	Reserved
16.00.00	Reserved
17.00.00	California Requirements
17.01.00	Statement of compliance
17.01.01	General statement
17.01.02	Driveability statement
17.02.00	Supplemental data and certification review sheets
	Engineering evaluation of zero evaporative emissions under any and all operating conditions (for vehicles equipped with fuel-fired heater only)
17.03.00	
17.04.00	Credits
17.04.01	Description of multi-manufacturer agreements
17.05.00	Vehicle safety
17.05.01	All information on safe handling of vehicle
17.05.02	Information on safe handling of battery system
17.05.03	Description of emergency procedures
17.06.00	Description of fuel-fired heater / fuel tank evaporative system

1 COMMUNICATIONS

1.01 Mailing information

01.01.01 Certification information

Tesla, Inc
3500 Deer Creek Road
Palo Alto, CA 94304

01.01.02 Responsible officials

01.01.03 - Primary Contact

Mr. Suraj Nagaraj, Sr Director- Vehicle Homologation
Telephone 510-249-8749

01.01.04 - Secondary Contact

Mr. Sandeep Pannu / Mr. Derek Yam - Vehicle Homologation
Telephone 341-345-5043 / 650-793-0327

3 FACILITIES, EQUIPMENT AND TEST PROCEDURES

Internal range test data are on file at Tesla

3.01 Procedure to determine mass emissions of the fuel-fired heater

Not applicable; vehicle not equipped with a fuel fired heater.

3.02 Battery pre-conditioning procedures

The lithium ion battery cells are cycled by the battery cell manufacturer before they are assembled into battery packs. There is no further pre-conditioning necessary.

3.03 Vehicle Configurations and sub configurations

Refer to Appendix 03.03

3.04 TEST PROCEDURES

40 CFR 86.1831-01 ©, 40 CFR 600.007, SAE J1634 (as revised 2012-10) was followed for all Range testing and SAE J2263-2008 referred by 40CFR 1066.305 was followed for Road load measurement.

SPECIAL TEST INSTRUCTIONS

See attachment

04.00 Statement of Compliance

This vehicle conforms to US EPA Federal Tier 3 Bin 0 and State of California regulations applicable to 2024 Model Year new ZEV Heavy-duty Vehicles

05.00 RESERVED

06.00 MAINTENANCE

6.01 Test vehicle scheduled maintenance

Not applicable.

6.02 Recommended customer maintenance schedule

See Owner Hand Book.

6.03 Lubricants and heater fuels

Heater fuel:

Not applicable

Transmission Lubricant:

Capacity

Factory Fill

Make

3250 mL (Front), 8000 mL (Rear)

Trade name

SK

Type

KAF I

Viscosity

Synthetic

Viscosity

29.8 cSt at 40°C

6.5 cSt at 100°C

Test Vehicle

Same as factory fill

07.00 LABELS

07.01 Label locations

VECI Emission Label

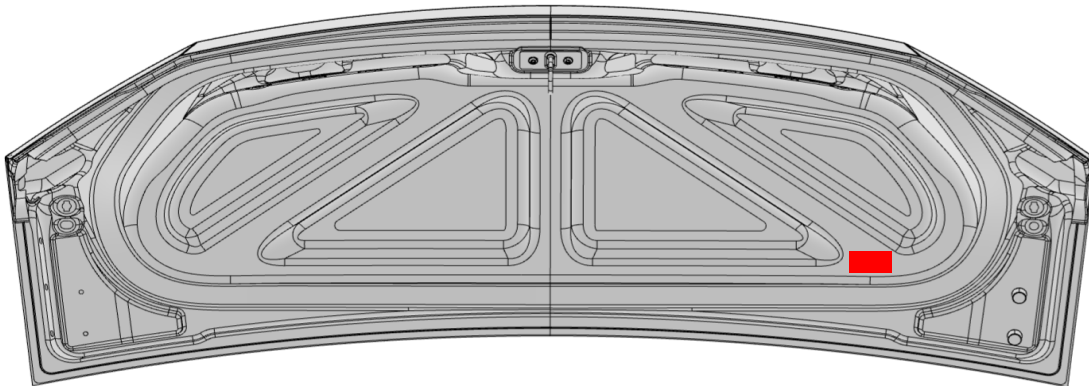

See 07.02

Monroney Label

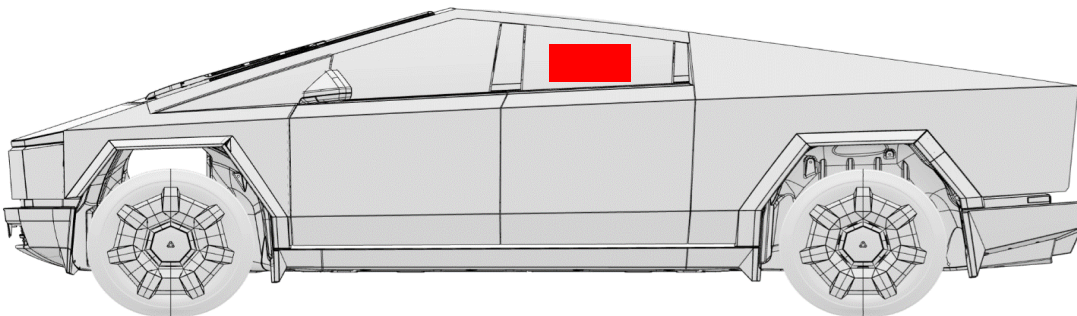

See 07.03

07.02 Emission Control Information label: 2024 Model Year

(Mandated in CFR Title 40, Part 86; §86.1807. Label format agreed with EPA)

VEHICLE EMISSION CONTROL INFORMATION

THIS VEHICLE CONFORMS TO U.S. EPA REGULATIONS APPLICABLE TO 2024 MODEL YEAR NEW TIER 3 BIN 0 HEAVY-DUTY VEHICLES AND TO CALIFORNIA REGULATIONS APPLICABLE TO ZEV MEDIUM-DUTY VEHICLES AND IS CERTIFIED FOR SALE IN CALIFORNIA.

MODEL: 2024 TESLA CYBERTRUCK
MOTOR: 3 PHASE AC
TEST GROUP: RTSLD00.0L3C
EVAPORATIVE FAMILY: RTSLR0000L3C

07.03 California Environmental Performance Index label: 2024 Model Year

(Mandated in California Environmental Performance Label Specifications for 2009 and Subsequent Model Passenger Cars, Light-Duty Trucks and Medium-Duty Passenger Cars. Label format agreed with EPA/ CARB)



Cybertruck FE Label

California Air Resources Board Electric Vehicle

Environmental Performance

These ratings are not directly comparable to the U.S. EPA/DOT light-duty vehicle label ratings.
For information on how to compare, please see www.arb.ca.gov/ep_label.

Protect the environment. Choose vehicles with **higher ratings**:

<p>Greenhouse Gas Rating (tailpipe only)</p> <p>A+</p> <p>A+  D</p> <p>Cleaner</p>	<p>Smog Rating (tailpipe only)</p> <p>A+</p> <p>A+  D</p> <p>Cleaner</p>
---	---

Does not include emissions from producing electricity.

Vehicle emissions are a primary contributor to climate change and smog. Ratings are determined by the California Air Resources Board based on this vehicle's measured emissions.

 **CALIFORNIA**
AIR RESOURCES BOARD

07.04 Projected sales information (Confidential)

08:00 GENERAL TECHNICAL DESCRIPTION

08.01 DESCRIPTION OF PROPULSION SYSTEM

Front Drive Unit:

Traction motor × 1,
Fixed ratio gearbox,
Drive inverter

Rear Drive Unit:

Traction motor × 2,
Fixed ratio gearbox,
Drive inverter

8.02 DESCRIPTION OF MOTOR(S)

Front motor:

Three phase, six pole, internal permanent magnet motors

Rear motor:

Dual independent, three phase, six pole, internal permanent magnet motors

8.03 DESCRIPTION OF BATTERIES

The battery packs used in the Tesla Cybertruck is one of the most technically advanced lithium-ion battery packs in the world. Using customized automotive grade lithium-ion cells, the Tesla battery achieves unmatched energy density and enables the long range capability of the vehicle. The low-profile flat packaging enables an efficient and functional occupant area. The battery has replaceable active short circuit protection that is accessible with the battery in the vehicle via an access panel. A set of switches inside the pack disconnect high voltage from the positive and negative terminals on the battery pack when not in use. To disable the switches from closing during vehicle service, the 12V power feed can be disconnected at the low voltage wiring connector into the battery pack. The battery control system consists of the Battery Monitoring System (BMS) which controls the switches, measures pack current and voltages, electrical isolation of the battery from chassis ground and monitors cell voltages and module temperatures from the Battery Monitor Boards (BMBs) installed on each of the modules.

08.03.01 Battery charging capacity

The fully charged battery contains a minimum amount of usable energy when new, based on the battery type/option fitted to the vehicle.

08.03.02 Self-discharge information

The self-discharge rate of the High Voltage battery is likely to be less than 0.5% per month.

08.03.03 Description of thermal management system

The Tesla battery pack contains an integrated cooling system to ensure that the individual cells are maintained at, or close to, their optimum operating temperature. Incorporated in the vehicle system is an inline heating element to raise and a chiller to lower the pack temperature, when required.

08.03.04 Definition of end-of-life

The battery pack end-of-life shall be determined by Tesla's local service centers with Proper inspection and test methods.

08.03.05 Description of battery disposal plan

Tesla's lithium ion battery packs do not contain heavy metals such as lead, Cadmium, or mercury. They are exempt from hazardous waste disposal standards in the USA under the Universal Waste Regulations. However, they do contain recyclable materials, and Tesla plans to recycle all battery packs removed from vehicles.

Tesla highly recommends that all battery packs be taken to local Tesla service facilities and recycled by Tesla or Tesla authorized agencies, so that the battery packs can be recycled in a safe and efficient manner.

If disposing independently, without return to Tesla, then the owner must assume responsibility for recycling in a safe and legal manner. If an owner does assume this responsibility, Tesla recommends consulting with the appropriate local, state or federal authorities to determine the appropriate methods for disposal and recycling. Keep in mind that disposal regulations may vary dependent on location.

For more information on the recycling of Tesla custom battery packs, please call Tesla Customer Service at 1-877-79TESLA (1-877-798-3752).

08.04 DESCRIPTION OF CONTROLLER / INVERTER

The drive inverter performs several critical functions in the Tesla Cybertruck including torque control, power and torque limit enforcement, and status monitoring. The drive inverter is an integral part of the drive unit.

08.05 DESCRIPTION OF TRANSMISSION

The transmission is a fixed ratio, mechanical, transversely mounted gearbox with integral final drive (transaxle configuration).

The shift position is available on the center screen or on the overhead selector. There are four shift positions - one reverse, one drive, one neutral, and one park position. Selecting either forward or reverse position enables drive current to the motor to generate the appropriate torque. There is no physical reverse gear needed.

In addition, the park button is used to operate the electrically-actuated park brake.

8.06 DESCRIPTION OF CLIMATE CONTROL SYSTEM

General Specifications:

The Cybertruck climate control modes include Defrost, Panel and Floor (or any combination of these three). The system consists of two panel vents, two front row floor vents, defroster vent, second row floor vents, second row console vents with positive air shut off and turning vane manual control.

08.06.01 Electric cabin heater

The heater unit incorporating a variable speed electric fan is located in the front of the chassis tub with ducting directing the blown air to defrosting, face level and floor level vents in the passenger compartment.

The heater element is of the heat pump, drawing HV electrical energy from the battery pack High Voltage.

Tesla Cybertruck's heat pump reduces the energy required by the HVAC system in both heating and cooling scenarios. The energy required to heat the cabin varies by weather and occupant comfort needs, but on-average consumes approximately 10% of the total energy available for driving. However, even moderately cold weather (0°C), consumption can increase to 25% or more. A heat pump consumes a small amount of electrical energy to thermodynamically "upgrade" low-temperature (less useful) thermal energy to higher-temperature (more useful) thermal energy, making it suitable for occupant comfort. That is, for a given electrical power input, a heat pump will return 1 to 5x in useful heating power; an electrical cabin heater provides 1:1 in heating power, and therefore is far less efficient.

Typically, this is accomplished using conventional refrigeration system components, e.g., compressors, valves, heat exchangers and so on, configured or connected together in a specific way. Tesla's heat pump uses conventional components with unconventional flexibility or cycle configuration. A heat pump must generally have a low-temperature source from which to draw energy. Tesla's system enables the heat pump source to be either the power-train coolant loop, e.g., low-temperature waste heat produced naturally by the vehicle while driving, ambient air, the battery thermal mass, the cabin thermal mass, or combinations thereof. Another advantage of this architecture is the ability to reject heat into the battery pack via a liquid-cooled condenser for a limited amount of time during cabin cooling scenarios when the temperature of the battery is modest. Therefore, for most startups with AC on, the relatively cool, well-coupled, large thermal mass serves to lower discharge pressure and therefore reduces compressor input power relative to a conventional air-cooled condenser setup.

Modern automotive heat pump systems using an HFC/HFO refrigerant suffer from low heating capacity in extremely cold ambient conditions, e.g., minus 10°C and below. Therefore, these conventional systems retain an expensive high-voltage cabin heater to cover heating deficits whenever the heat pump capacity is insufficient. Tesla's heat pump system also provides ways to remove a cabin air high voltage PTC heater completely by using the compressor as an electrical heater in specific scenarios. In fact, the electrical power draw capability of the compressor significantly exceeds a typical HV cabin PTC heater capability. This last point is accomplished via Tesla's unique architecture – the cycle is configured in such a way to provide a controlled environment for the compressor, regardless of ambient conditions, and ultimately unlocks the full electrical input power. Therefore, Tesla's thermal system can sometimes operate like a heat pump (heat efficiently) and sometimes like an electrical heater when heat pump capacity is not sufficient for comfort – using the same compressor.

08.06.02 Fuel-fired heater

Not applicable

08.06.03 Air conditioning

The Cybertruck air conditioner system is an R1234yf refrigerant consists of a high voltage electric scroll type with integrated inverter with High Voltage Interlock Loop. The compressor Oil is Poly Olefin Ester oil that is non-conducting.

08.06.04 Climate control system logic

Vehicle Controller printed circuit boards activate actuators and responds to evaporator air outlet temperature sensor, PTC heater outlet temperature sensor and air duct temperature sensors, as well as user demands from center display.

08.06.05 Tamper resistance of climate control system that includes a fuel-fired heater

Not applicable

08.07 DESCRIPTION OF REGENERATIVE BRAKING SYSTEM

Regenerative braking (RGB) occurs when the driver lifts his foot from the accelerator pedal while the vehicle is moving; the experience is analogous to engine braking on a gasoline-powered car with a conventional manual transmission. The friction braking system is independent of RGB.

The amount of RGB torque generated depends on the accelerator pedal position – largest when the accelerator pedal is fully released, decreasing as the pedal is depressed, reaching zero torque when the pedal reaches its neutral torque position (a position that is a function of vehicle speed). The max RGB deceleration also varies depending on vehicle speed. The maximum RGB profile is defined as a target total deceleration rate as a function of vehicle speed. The max RGB profile is tailored to everyday driving conditions, which typically exhibit higher deceleration rates at lower speeds.

When the battery pack is near maximum capacity, regenerative braking function will be limited to ensure the maximum capacity of the battery is not exceeded. Any RGB limiting will be ramped in gradually to allow the driver to adapt to the changing RGB performance. When the battery pack is below 0 degrees, RGB will not be allowed because the batteries are not rated to accept charge below this temperature. Any RGB limiting will be ramped in gradually to allow the driver to adapt to the changing RGB performance. The vehicle notifies the driver of any limits on the regenerative braking function.

08.08 DESCRIPTION OF VEHICLE ELECTRICAL SUPPLY EQUIPMENT (CHARGER)

The Tesla Cybertruck is capable of accepting energy either from a permanent facility installed at the owner's location or from many readily available power outlets when 'on the road'.

Optional - The dedicated High Power Connector (HPC) can be purchased separately from the vehicle and a certified electrician will confirm the capabilities of the residential supply circuit at the vehicle owner's location. Confirmation of a satisfactory residential electrical Supply will lead to the installation of a hard-wired HPC unit, this will expedite vehicle charging at the most efficient rate. The HPC can supply available current up to the maximum and incorporates electronic systems that communicate with the vehicle control systems to indicate the maximum available current so that the vehicle can determine the amount and rate of charge required.

Standard - Charging at rates lower than or equal to 32A can also be achieved via a mobile connector. The universal mobile connector is included as standard in the purchase of every Cybertruck and is an individual cable that connects the vehicle to any available domestic power outlet and can deliver current to a maximum of 32 Amps. The Mobile Connector incorporates similar electronic circuitry as the HPC to communicate with the vehicle and manage the charging process. The charging duration is 12 hrs. at the rate of 32 Amps.

The vehicle is also capable of accepting DC current from an off-board charger (Supercharger).

08.08.01 Proper recharging procedures

The charging system adjusts automatically to the available AC line voltage, frequency and current, within limits. The charging system in the vehicle works in conjunction with either of the three external charging stations; the permanently installed HPC, the permanently installed supercharger or the portable Mobile Connector.

Anytime the EV Inlet door is opened, the vehicle will prepare to enter CHARGE state. Once the user connects either supply cable to the vehicle, the charging system signals to the vehicle that it is ready to deliver the charge. The vehicle locks the cable onto the vehicle and then indicates that it is ready to accept energy and charging will commence. Failure of any of these steps will result in fault condition and lack of **full charging capability**. Vehicle could still charge on low power if handle lock is not engaged.

LED Color Chart	
LED Color	Chargeport State
Solid White	Charging cable can be removed or inserted
Solid Amber	Cable is inserted, but not properly latched
Solid Red	Either the charger, charge port, or Electric Vehicle Supply Equipment (EVSE) is not operating as expected
Flashing Green	Charging at expected current
Flashing Amber	Charging at reduced current
Solid Green	Charging is complete
Solid Blue	Pilot is present

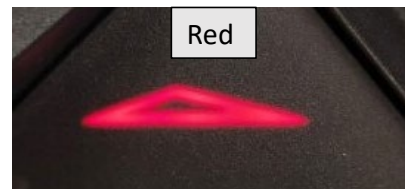
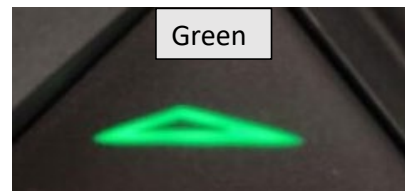
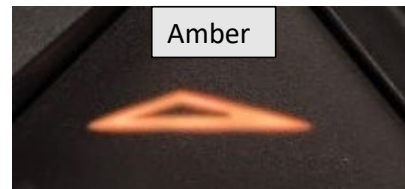

If the battery temperature is near or below freezing temperatures, normal charging will not occur. The vehicle will identify this condition and will begin heating the battery coolant and circulating the coolant to raise the battery temperature to enable charge. When the pack temperature rises to a temperature within the allowable charging range, heating will reduce or stop and charging will commence.

08.08.02 Power requirements necessary to recharge vehicle

Cybertruck comes with one on-board charger is capable of a maximum of 48A on 208V or 240V outlets and 12A on 120V outlets.

08.10 OTHER UNIQUE FEATURES (i.e. solar panels)

Not applicable; vehicle is not equipped with any such features.

08.11 DESCRIPTION OF WARNING SYSTEM(S) FOR MAINTENANCE / MALFUNCTION

The Tesla Cybertruck is equipped with a tell-tale lamp located in the center screen cluster to indicate any malfunctions through user alerts e.g. “battery failure” with battery symbol.

The tell-tale is complemented by more detailed information exhibited on the Center Display. An additional driver aid which indicates the nature of the malfunction as well as a wide range of additional vehicle data, such as when maintenance is needed.

08.11.01 Cut-off terminal voltages for prevention of battery damage

The control electronics inside of the Drive Unit and Charger are programmed not to allow the unit to drive the voltage of the battery above or below hard voltage limits. If the battery pack is unable to achieve a desired response from these systems and the voltage reaches above or below a set limit, the two switches inside the battery pack will open, disabling the entire high voltage system in the car.

8.12 DESCRIPTION OF DYNO MODE

Tesla, Inc. implemented user interface (UI) features that enable access to our “Dyno Mode” for all users. This feature is required to be enabled to maintain representative driving controls while testing on a chassis dynamometer.

In order to preserve the proper driving functionality and behavior, Dyno Mode executes the following features:

- Disable Stability Control to ensure no false interaction with the dyno.
- Disable Traction Control to ensure no false interaction with the dyno.
- Disable Active Drive Line Damping to avoid inducing oscillations in the dyno.
- Force the torque split to be as it would be under normal straight-line driving conditions
- Disable Brake Disk Wipe
- Disable vehicle movement plausibility monitor to ensure the availability of autonomous brake actuation on Dyno.

When the Stability Control and Traction Control systems become faulted, as is the case on a dynamometer where driving is detected but movement is not, regenerative braking is disabled so that unintended braking torque does not lead to loss of traction or control on low friction surfaces. Disabling Stability Control and Traction Control prevents those systems from disrupting regenerative braking behavior, maintaining the most representative driving energy consumption.

Dyno Mode can be activated by the user, according to the steps in the driver's guide.

Dyno Mode can be deactivated by the user by pressing the “Power Off” button within the Safety & Security tab of the UI.

8.13 DESCRIPTION OF COASTDOWN MODE

Tesla Does not use Coastdown mode for testing

09.00 RESERVED

10.00 RESERVED

11.00 STARTING AND SHIFTING SCHEDULES

11.01 Starting

The Cybertruck does not have a traditional starter switch and instead has a smart entry system for greater safety and customer convenience. The smart entry system comprises of an authenticated phone (using Bluetooth Low Energy or internet connectivity) or key card (using Near Field Communication), a weight sensor embedded into the driver seat, and the brake pedal.

ENTERING

An authenticated phone can be used to passively unlock the car when connected, in range and a door handle is pulled or trunk release button is pressed.

The Tesla mobile app on an authenticated phone can be used to manually unlock the vehicle.

A key card can be used to unlock the car by scanning the card on the b-pillar.

After a successful key card scan on the b-pillar or center console:

- a. Vehicle is authorized to Drive within a reasonable time period. Time period is extended based on additional user interaction which include: driver opening their door, driver sitting down, driver closing their door while seated.
- b. If time period is exceeded, upon brake press, instruct driver to rescan key card on the center console to reauthorize Drive.
- c. Accessory Mode functions will be available without the user having to rescan their key card.

LOCKING

An authenticated phone can be used to passively lock the car when the phone is disconnected or moved away from the vehicle. This passive function can be disabled in controls on the touchscreen.

The Tesla mobile app on an authenticated phone can be used to manually lock the vehicle.

A key card can be used to lock the car by scanning the card on the b-pillar. There is no passive locking with key cards (car does not auto lock).

Note: Using a key card to lock/unlock will be equivalent to an active lock/unlock—i.e., clicking on the key fob to lock and double-clicking to unlock.

STARTING

If successful interaction between authenticated phone or the key card and vehicle controller occurs, the system deactivates the immobilizer. Immobilizer deactivation only happens after 2 conditions are met below. The vehicle then enters accessory mode analogous to a “ACC” position on a conventional IC engine. In this mode, low voltage (12V) is supplied to the vehicle allowing operation of the radio and other accessories connected to the accessory rail.

High Voltage (HV) necessary to enable vehicle propulsion is enabled only by the closing of the contactors, which can only be triggered when the following conditions are both satisfied,

1. Authenticated phone or key card is authorized and key code is validated AND
2. Brake pedal is depressed.

By requiring brake pedal activation, along with the appropriate key code, this system ensures the safety of vehicle occupants by not allowing self mobility of the vehicle without the driver providing proper control inputs (i.e., service brake activation) and appropriate driver authorization (i.e., presence of the key code). If either the service brake is not activated or the key code not present, the vehicle controller will not close the contactors and self-mobility is not possible.

If the brake pedal is depressed and the proper key code present, the drive rail will activate (immobilizer deactivates) and allows the vehicle to be shifted out of Park.

11.02 SHIFTING

Not applicable – the vehicle has a single-speed transmission.

12:00 -16:00 RESERVED

17:00 CALIFORNIA REQUIREMENTS

17:01 Statement of Compliance

17.01.01 General Statement

The production vehicles which are subject to registration or sale in the State of California will be, in all material respects, substantially the same in construction as test vehicles which are certified by the California Air Research Board; and will meet all the applicable emissions standards which are promulgated by the California Air Research Board in accordance with Section 43101 of the Health and Safety Code.

Tesla attests that the vehicle emission control label complies with the label durability requirements of the "California Motor Vehicle Emission Control and Smog Index Label Specifications", Title 13, CCR, Section 1965.

17.01.02 Drivability statement

This statement is no longer included in the California Exhaust Emission Standards and Test Procedures for 2001 and Subsequent Model Passenger Cars, Light-Duty Trucks, and Medium-Duty Vehicles (as of January 01 2006); as was the case in previous versions.

17.02 Supplemental data and certification review sheets

See attached

17.03 Engineering evaluation of zero evaporative emissions under any and all operating conditions (for vehicles equipped with fuel-fired heater only)

Not applicable; vehicle is not equipped with fuel-fired heater.

17.04 Credits

17.04.01 Description of multi-manufacturer arrangements

Not applicable; Tesla has no such agreements in place.

17.05 VEHICLE SAFETY

17.05.01 All Information for safe operation of vehicle

Tesla owner's manual is available at website <https://www.tesla.com/ownersmanual>

17.05.02 Information on safe handling of battery system

HANDLING

Do not short circuit, puncture, incinerate, crush, immerse, force discharge, or expose the battery pack to temperatures outside the specified maximum storage temperature range of -20°C to 60°C.

The battery pack has a nominal operating voltage of 400 VDC. The battery pack is sealed in a rigid metal case and its exterior is isolated from high voltage. Handling the battery pack is electrically safe provided the enclosure remains closed.

The battery pack contains hermetically sealed lithium ion cells that contain a number of chemicals and materials of construction. Risk of exposure to electrode materials and Liquid electrolyte will only occur in cases of mechanical or thermal abuse of the battery Pack.

STORAGE

Do not store the battery pack in a manner that allows terminals to short circuit. Do not place near heating equipment, nor expose to direct sunlight for long periods. The battery pack should only be stored in approved packaging and stacked no more than two (2) packages high. To maintain service life, the battery pack should be stored at a state of charge (SOC) of 15 to 50%.

TRANSPORT

Lithium ion batteries are regulated as Class 9 Miscellaneous dangerous goods (also known as “hazardous materials”) pursuant to the International Civil Aviation Organization.

(ICAO) Technical Instructions for the Safe Transport of Dangerous Goods by Air, International Air Transport Association (IATA) Dangerous Goods Regulations, the International Maritime Dangerous Goods (IMDG) Code, European Agreements concerning the International Carriage of Dangerous Goods by Rail (RID) and Road (ADR), and applicable national regulations such as the USA’s hazardous materials regulations (see 49 CFR 173.185). These regulations contain very specific packaging, labelling, marking, and documentation requirements. The regulations also require that individuals involved in the preparation of dangerous goods for transport be trained on how to properly package, label, mark and prepare shipping documents.

17.05.03 Description of emergency procedures

HIGH VOLTAGE EXPOSURE

If one of the Tesla products has been visibly damaged or its enclosure compromised, then practice appropriate high voltage preventative measures until the danger has been assessed (and dissipated if necessary).

FIREFIGHTING MEASURES

If a fire or explosion occurs when the battery pack is charging, shut off power to the charger. In case of burning lithium ion fires, flood the area with water. The water may not extinguish them, but will cool the adjacent batteries and control the spread of the fire. CO₂, dry chemical and foam extinguishers are preferred for small fires, but also may not extinguish burning lithium ion batteries. Burning batteries will burn themselves out. Virtually all fires involving lithium ion batteries can be controlled with water. When water is used, however, hydrogen gas may be a by-product which can form an explosive mixture with air. LITH-X (powdered graphite) or copper powder fire extinguishers, sand, dry ground dolomite or soda ash may also be used. These materials act as smothering agents.

Damaged or opened cells or batteries can result in rapid heating (due to exothermic reaction of constituent materials) and the release of flammable vapors. Water (and other items listed above) disperses heat when applied in sufficient quantity to a fire. Extended heat exposure can lead to ignition of adjacent cells with a potential complete envelopment of the battery pack if not cooled. An extinguished lithium ion battery fire can re-ignite due to the exothermic reaction of constituent materials from broken or damaged cells. To avoid this, remove sources of ignition and cool the burned mass by flooding with (or immersing in) water. Fire-fighters should wear self-contained breathing apparatus. Cells or batteries may flame or leak potentially hazardous organic vapors if exposed to excessive heat, fire or over voltage conditions. These vapors include HF, oxides of carbon, aluminum, lithium, copper, and cobalt. Additionally, volatile phosphorus pentafluoride may form at temperatures above 230° Fahrenheit. Never cut into the sealed battery pack enclosure due to the high voltage and electrocution risks.

If a decision is made to fight a battery fire aggressively, then large amounts of water should be applied from a safe distance with the intent of flooding the battery pack enclosure as completely as possible. Alternatively, if a decision is made to fight a battery fire defensively, then the fire crew should pull back a safe distance and allow the battery to burn itself out. Fire crews may choose to utilize a water stream or fog pattern to protect exposures or control the path of smoke.

FIRST AID MEASURES

Under normal conditions of use, the constituent battery cells are hermetically sealed. Contents of an open (broken) constituent battery cell can cause skin irritation and/or chemical burns. If materials from a ruptured or otherwise damaged cell or battery contact skin, flush immediately with water and wash affected area with soap and water. For eye contact, flush with significant amounts of water for 15 minutes and see physician at once. Avoid inhaling any vented gases. If a chemical burn occurs or if irritation persists, seek medical assistance. Seek immediate medical assistance if an electrical shock or electrocution has occurred (or is suspected).

17.06 Description of fuel-fired heater / fuel tank evaporative system

Not applicable; vehicle is not equipped with fuel-fired heater.