

– Toward Carbon Neutrality –

Toyota's Battery Development and Supply

Masahiko Maeda
Chief Technology Officer
Toyota Motor Corporation

September 7, 2021

The meaning of carbon neutrality

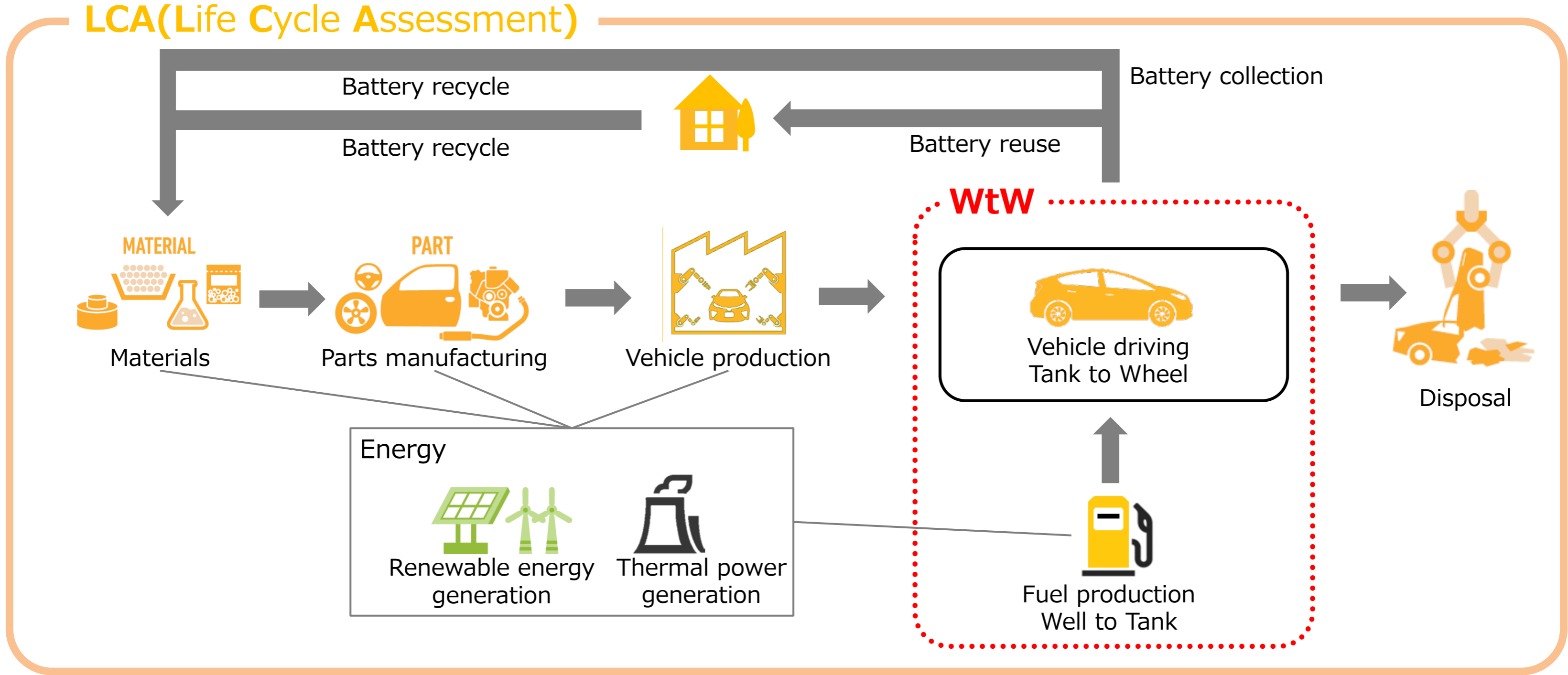

Carbon neutrality means zero life cycle CO₂ emissions

Toward carbon neutrality

Change in world's concentration of CO₂*

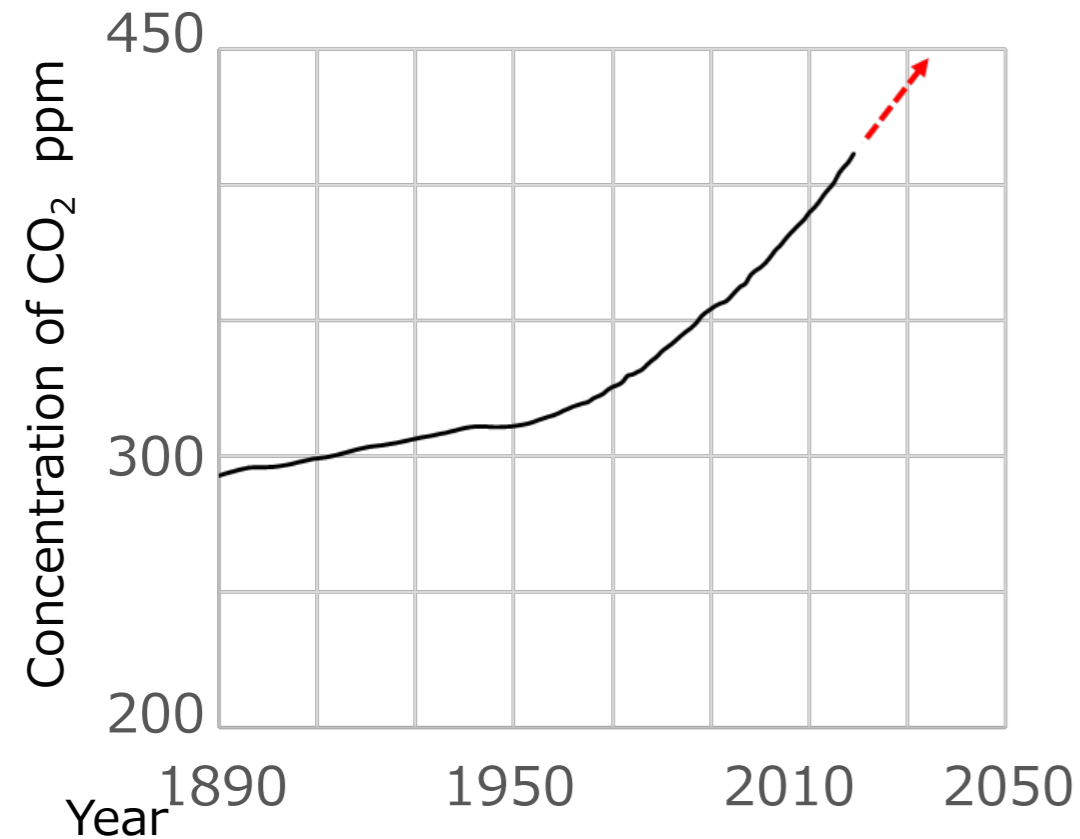

To immediately reduce CO₂ emissions:

- **Areas in which renewable energy will be widely used going forward**

Rapid electrification

1 BEV has the reduction effect of 3 HEVs

- **Areas in which renewable energy is already widely used**

Acceleration of the widespread use of ZEVs

* TMC summarized based on the data from Japan Meteorological Agency and World Meteorological Organization, etc.

Expanding options for achieving carbon neutrality

Electrified vehicle lineup toward carbon neutrality

HEV



PHEV



BEV



FCEV



Electrified vehicle sales volume forecast for 2030

Electrified vehicles **8** million units

including BEVs + FCEVs **2** million units

Providing our customers around the world
with sustainable and practical products

Path toward carbon neutrality: Electrified vehicle global sales

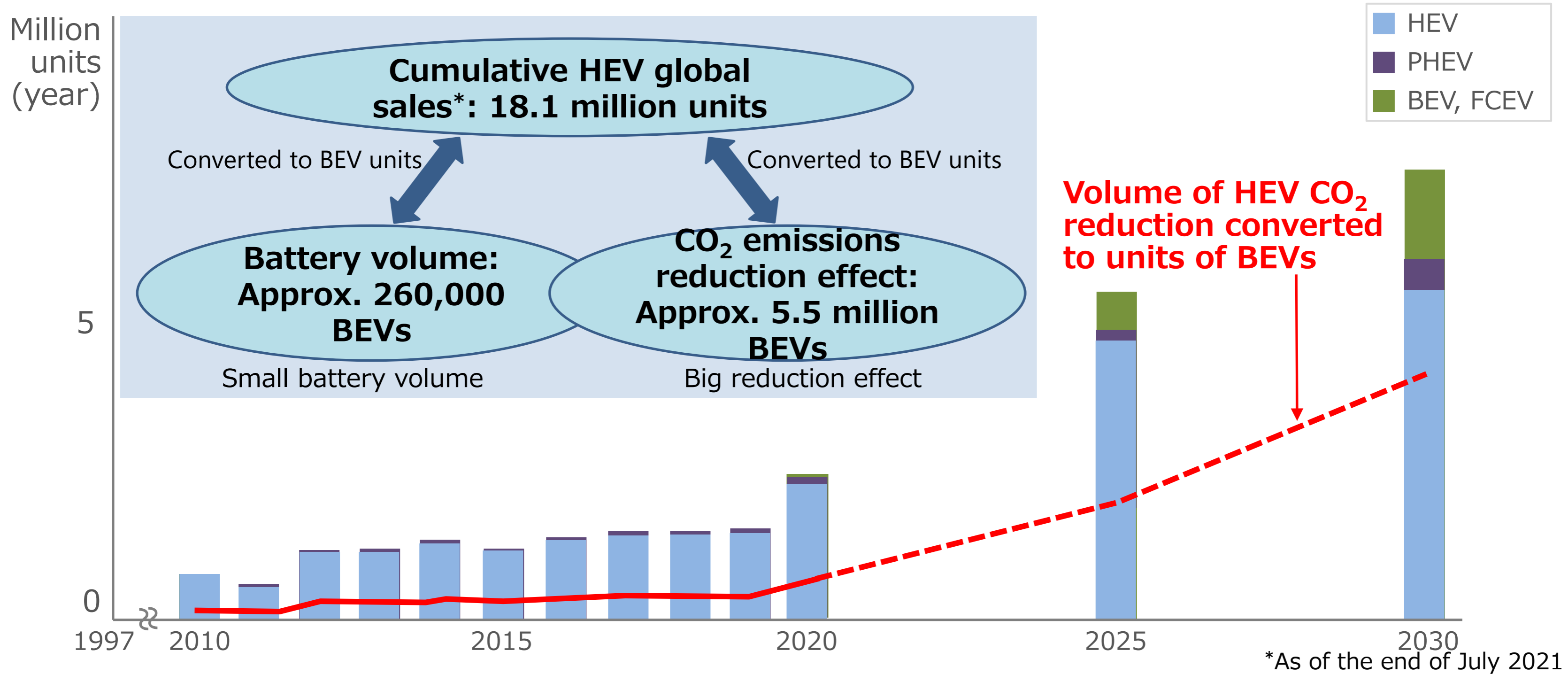

- Dissemination of HEVs has efficiently reduced CO₂ emissions with a small volume of batteries.
- Advancing BEV & PHEV technologies for further dissemination

Technologies supporting full lineup of electrified vehicles

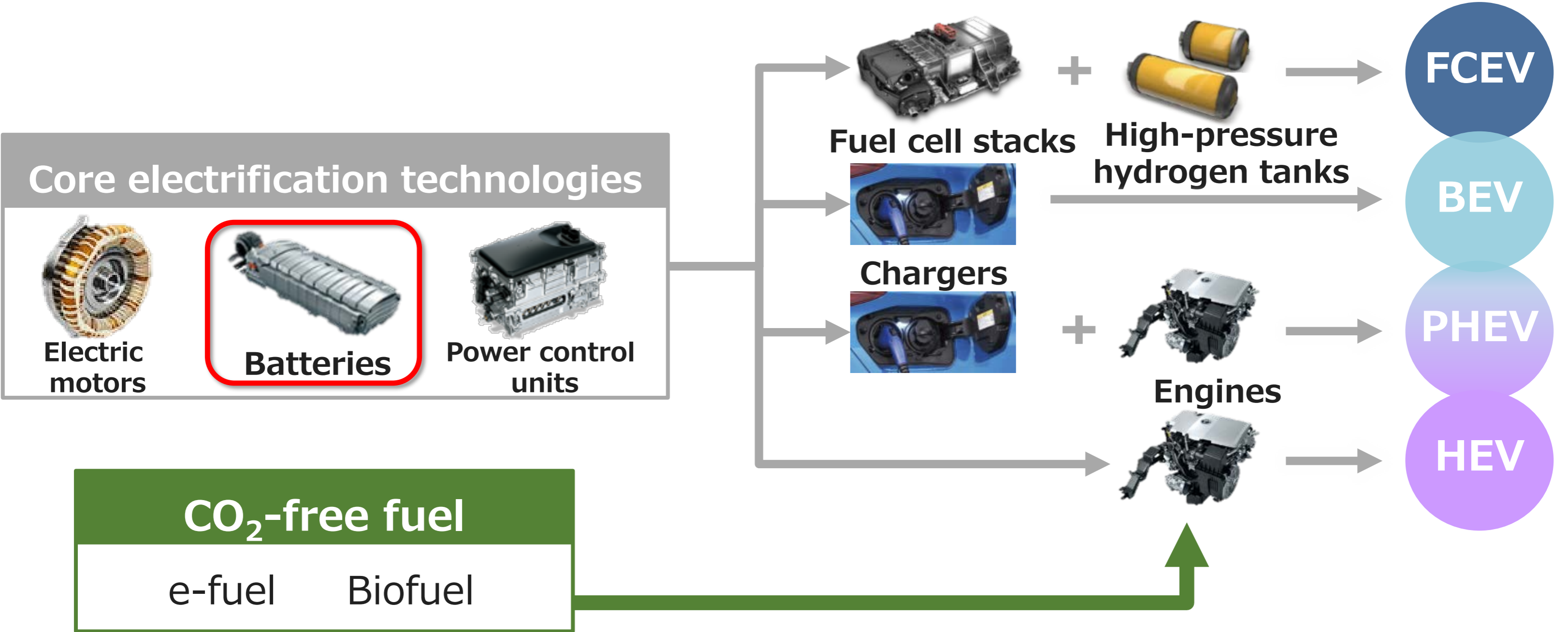

Full lineup of batteries

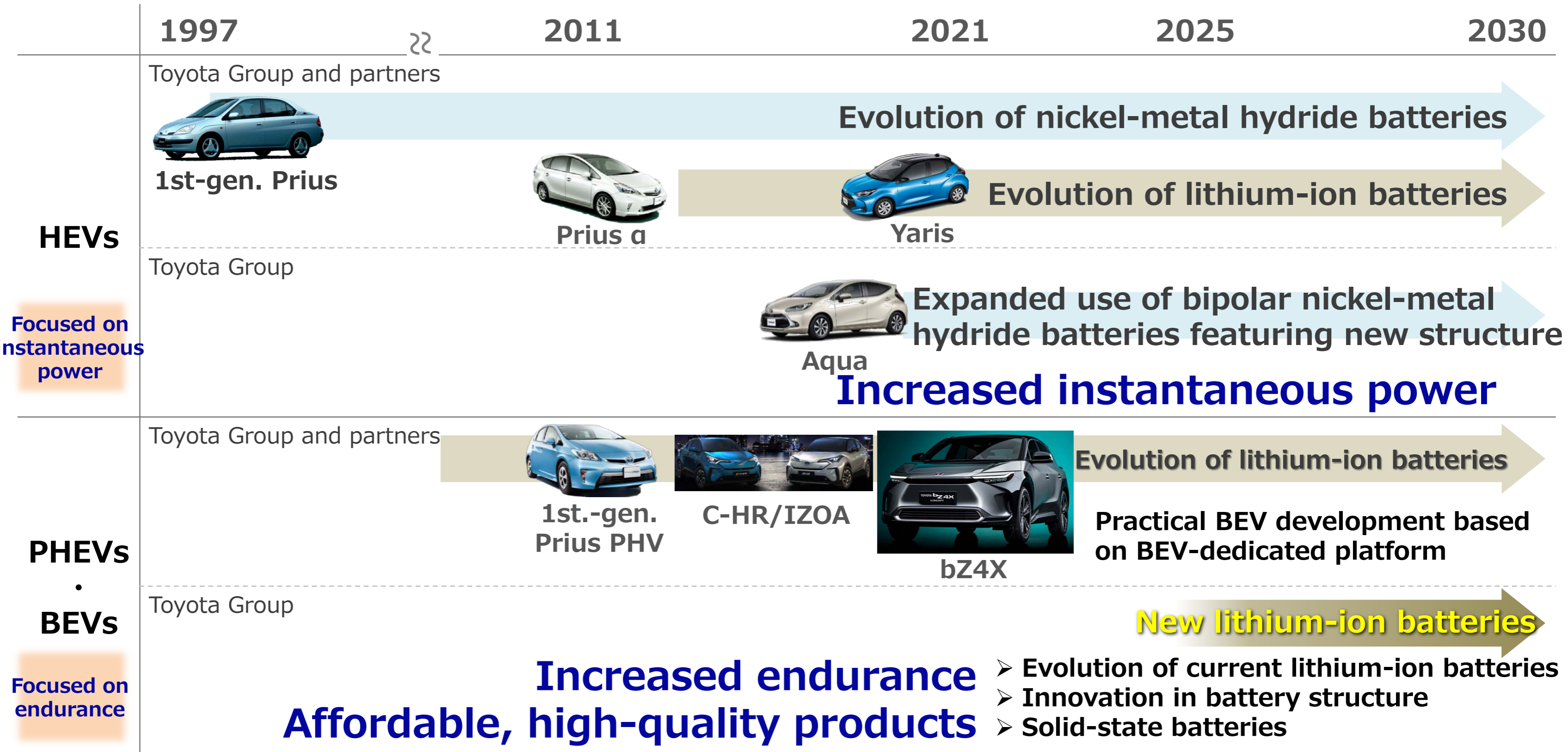

Battery development concept

Common to all batteries for HEVs, PHEVs, BEVs, and FCEVs

Security

Safety

Long service life

**High level
of quality**

Aiming to create safe batteries that can be used with peace of mind always and for their entire lifetime, have high resale value, and contribute to the building of a resource-recycling society

**Affordable,
high-quality
products**

**High-level
performance**

Giving electrified vehicles meaning through dissemination
Increasing customer choice

Highly balancing 5 elements to provide reliable batteries

Safety: Battery control systems

Verification of effect of high loads on battery internals

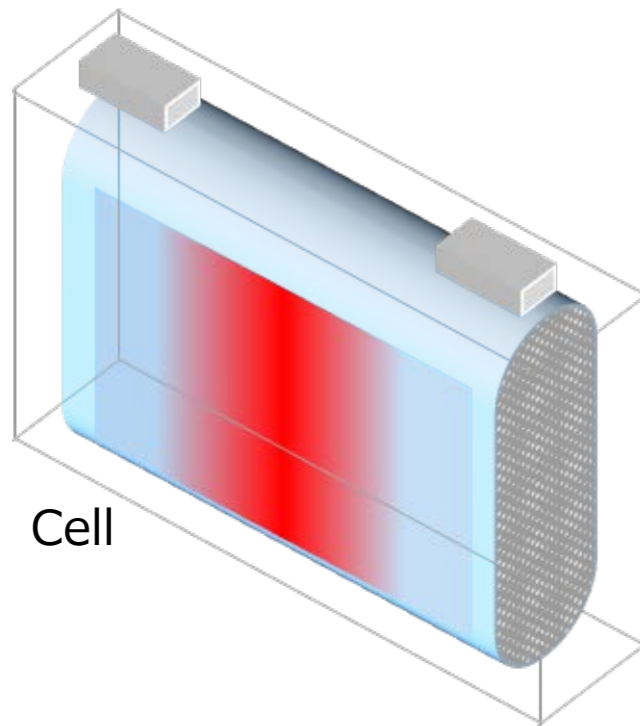

Simulated experiments to measure polarization of electrolyte components (which generates heat) during charging and discharging

Construction of principle-based theoretical model

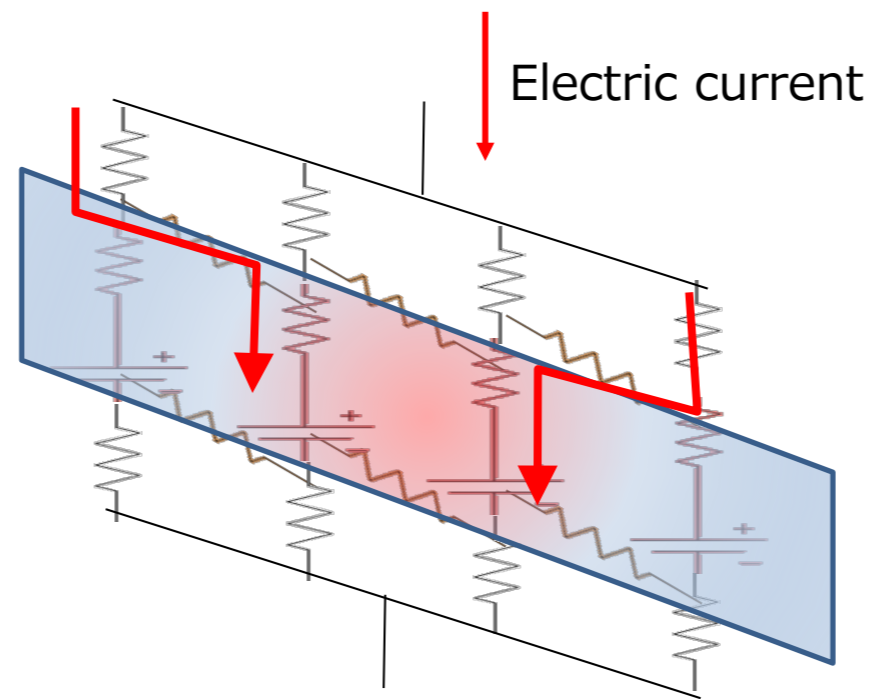

Confirmation of certainty and reliability based on vast amounts of experimental data

Control by multiple monitoring of voltage, current, and temperature

Example: Voltage monitoring of C-HR/IZOA BEVs

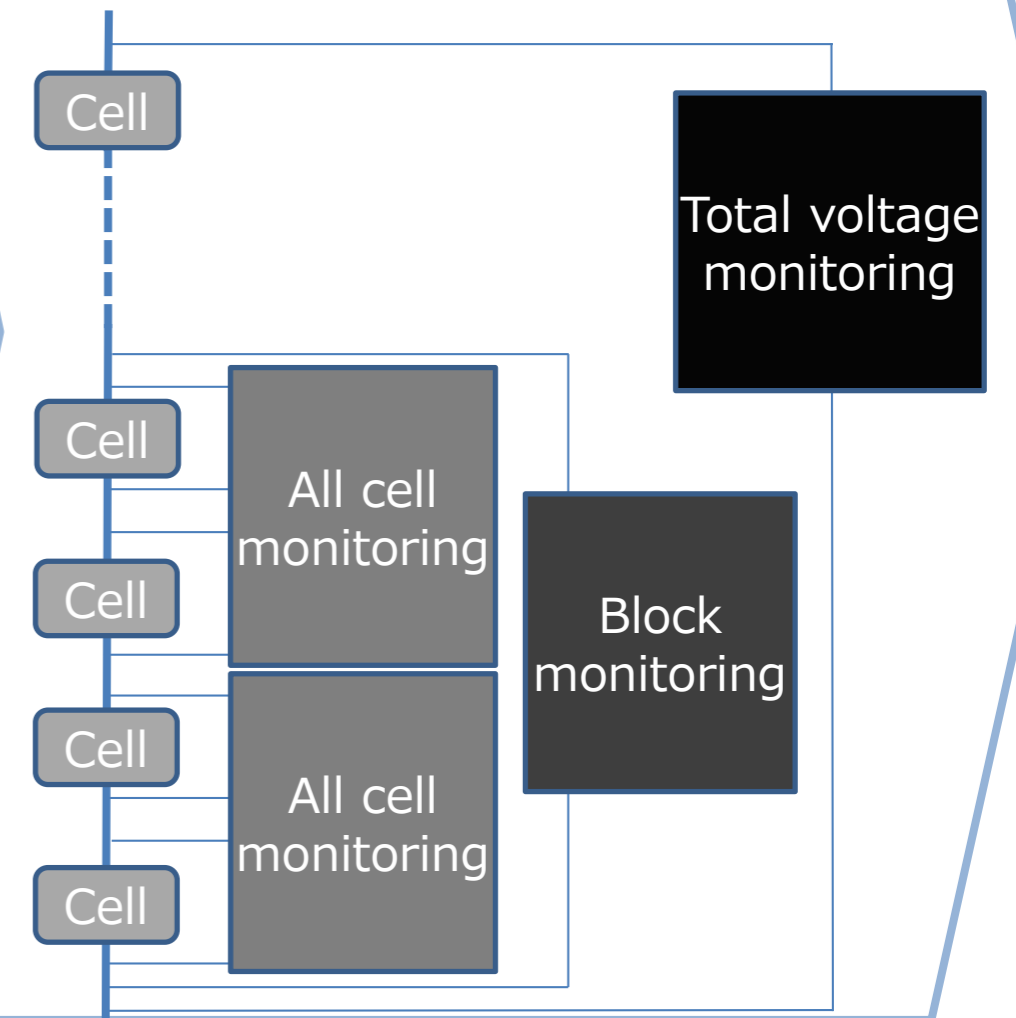

Multiple monitoring of voltage, current, and temperature to detect signs of and prevent abnormal heat

Long service life

Battery capacity maintenance rate

(Cruising range)

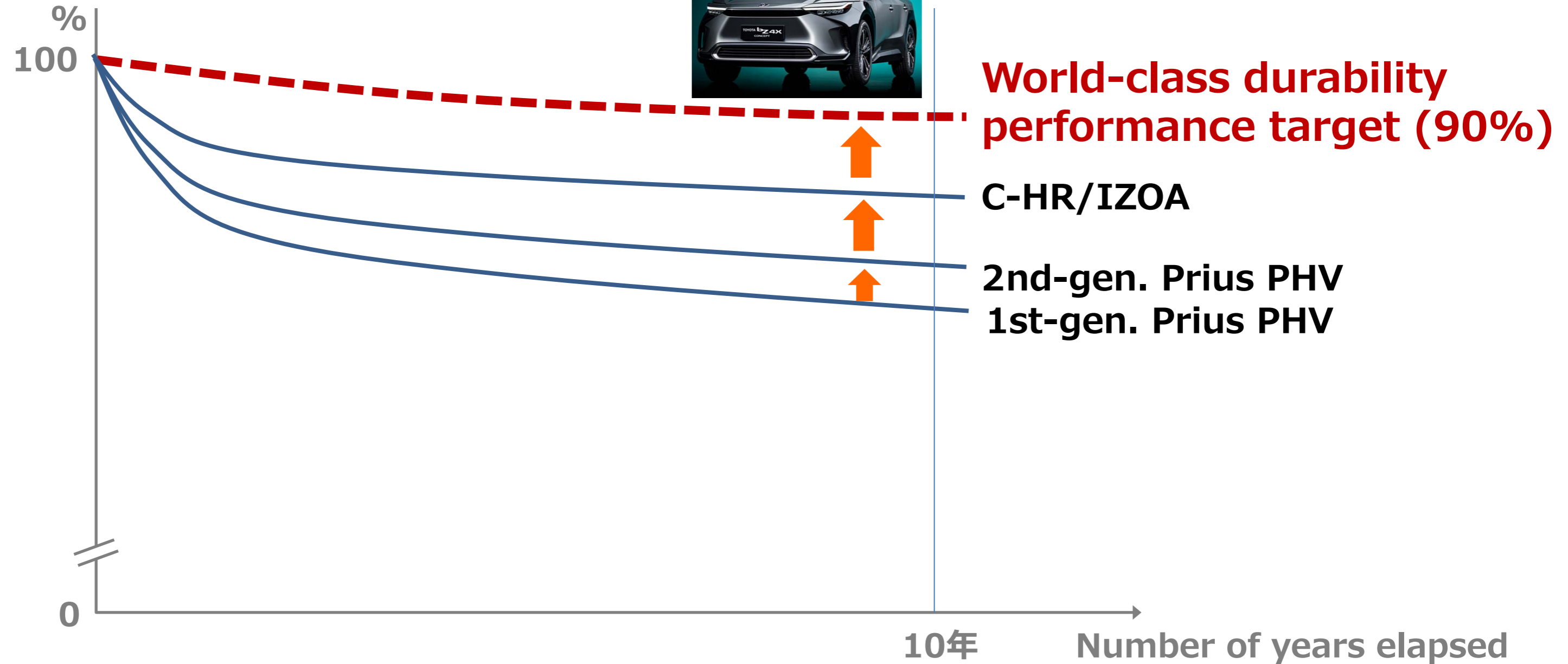

World-class durability performance target (90%)

C-HR/IZOA

2nd-gen. Prius PHV
1st-gen. Prius PHV

10年

Number of years elapsed

Aiming for world-class endurance with the TOYOTA bZ4X

Long service life: Applying HEV-honed technologies to BEVs

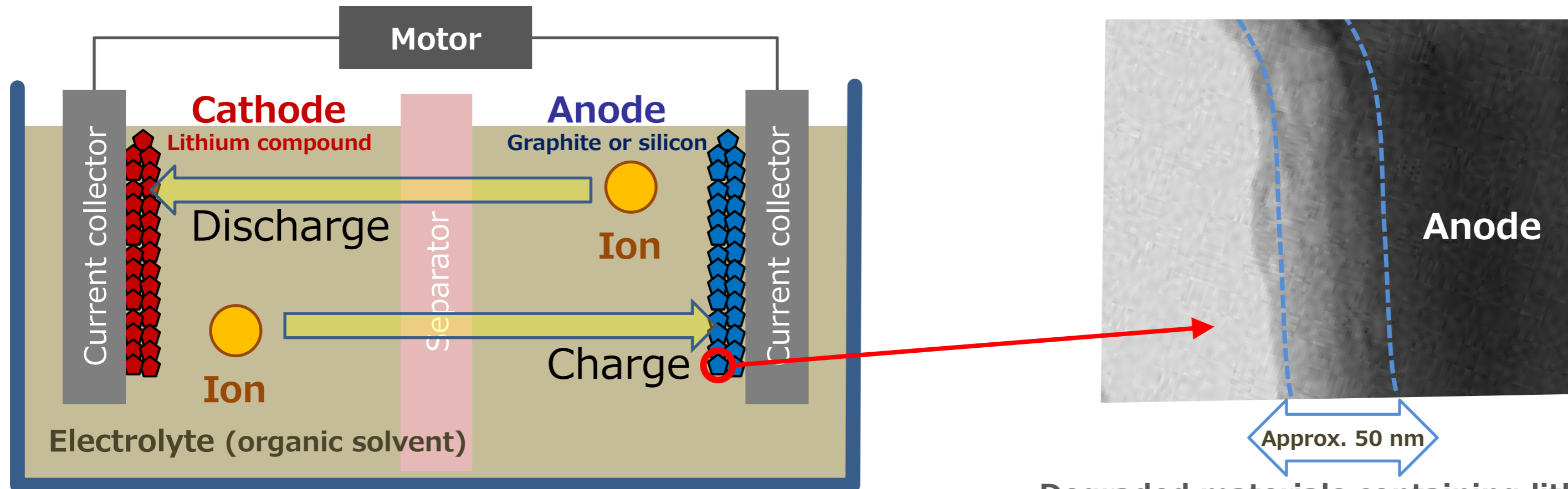

Inhibiting formation of degraded materials on anode surfaces

- Appropriate anode surface treatment to prevent degradation
- Design and production technology that prevents moisture contained in battery materials from being introduced into the battery
- Adoption of structure that ensures uniform cooling of battery
- Construction of control system that prevents load from being applied to the entire battery

Degraded materials containing lithium
One key to extending battery life

Suppress degradation in battery materials, pack structure, control systems, etc.

High-level quality: Control of metallic foreign matter

Effect on batteries of metallic foreign matter

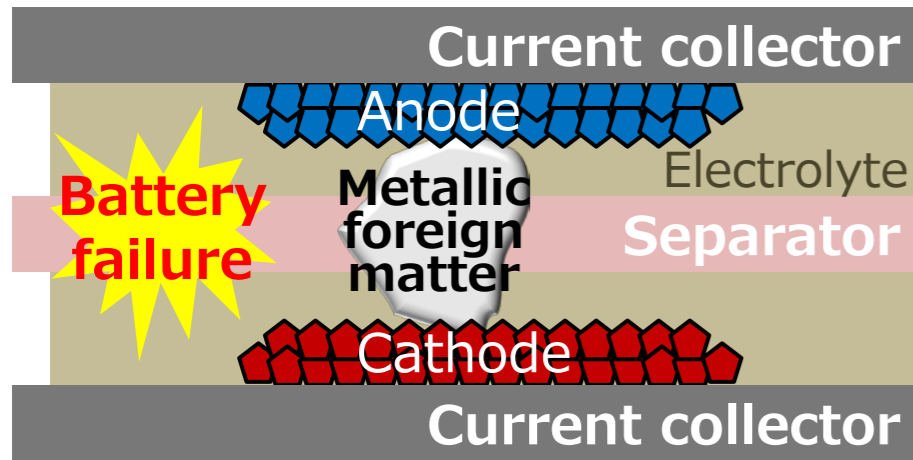

Battery failure due to contact between the anode and cathode



The need to control foreign matter

Effect of size and shape of metallic foreign matter on occurrence of abnormalities

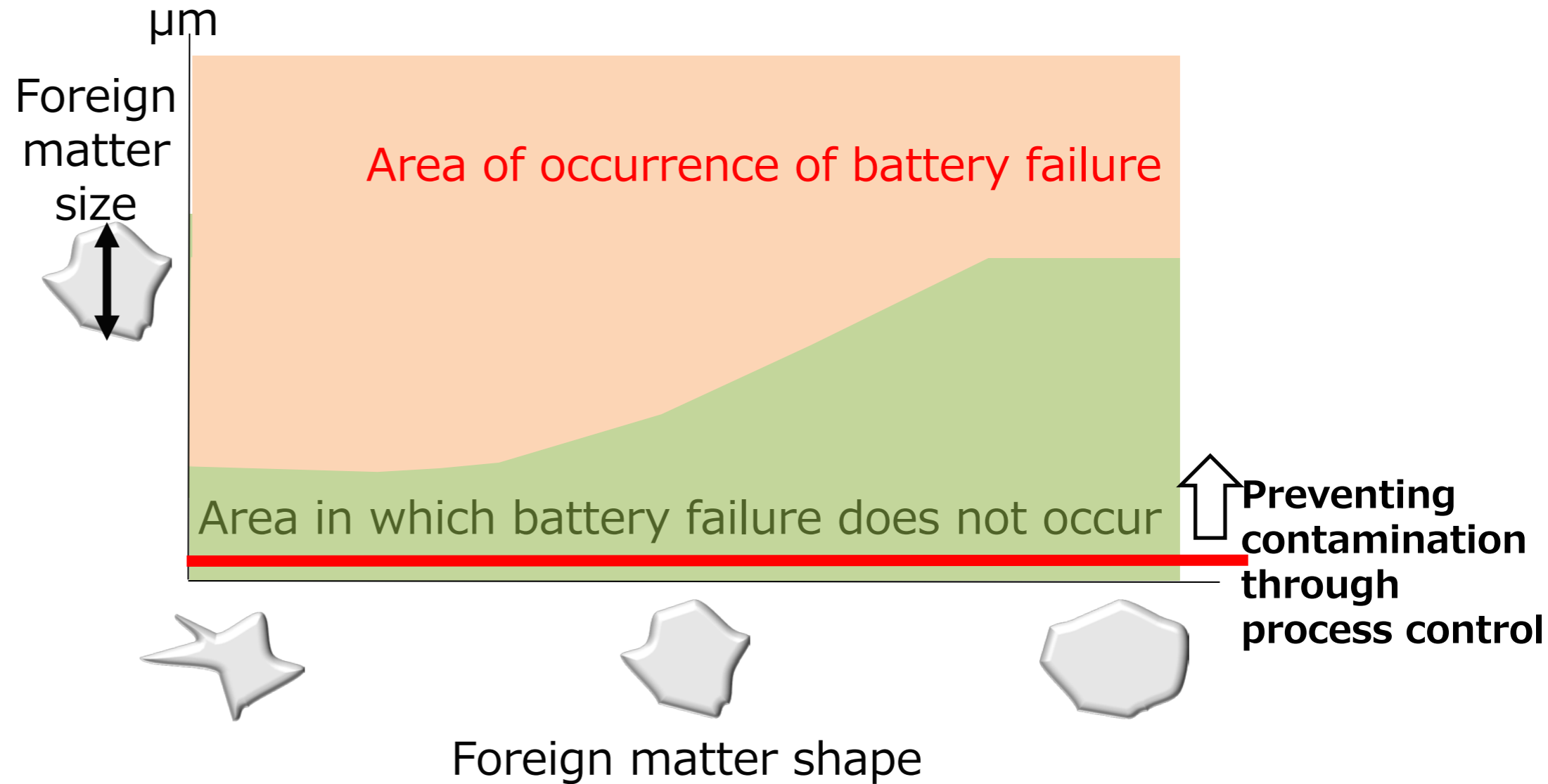

Determining the size and shape of foreign matter that can cause battery abnormalities and controlling the effect of foreign matter

Bipolar nickel-metal hydride battery

In the new Aqua - world's first use as a vehicle drive battery

Previous Aqua

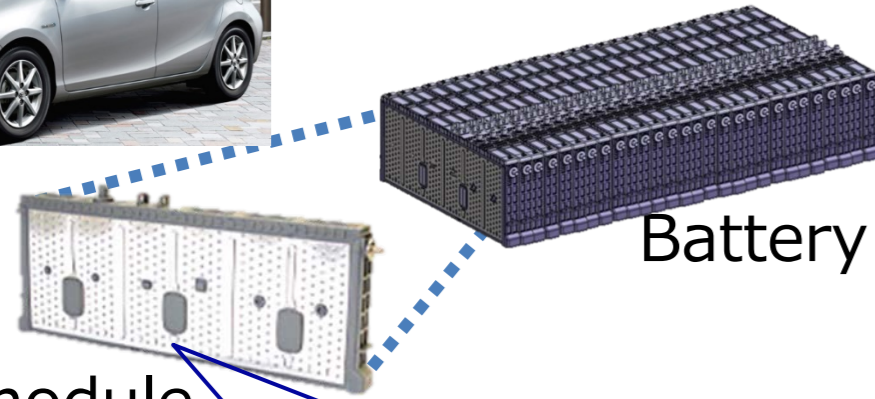

Battery stack

Doubled power density

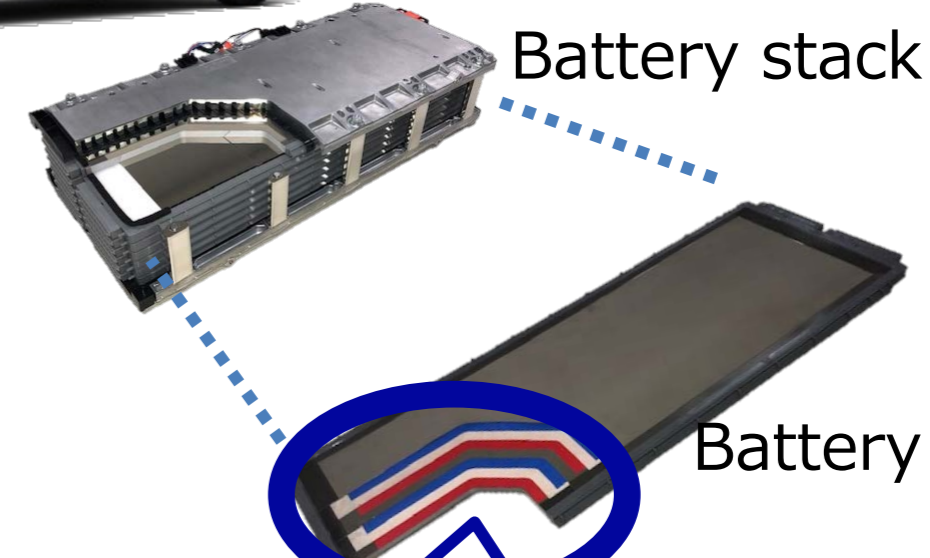

Battery stack

Battery module

Conventional structure

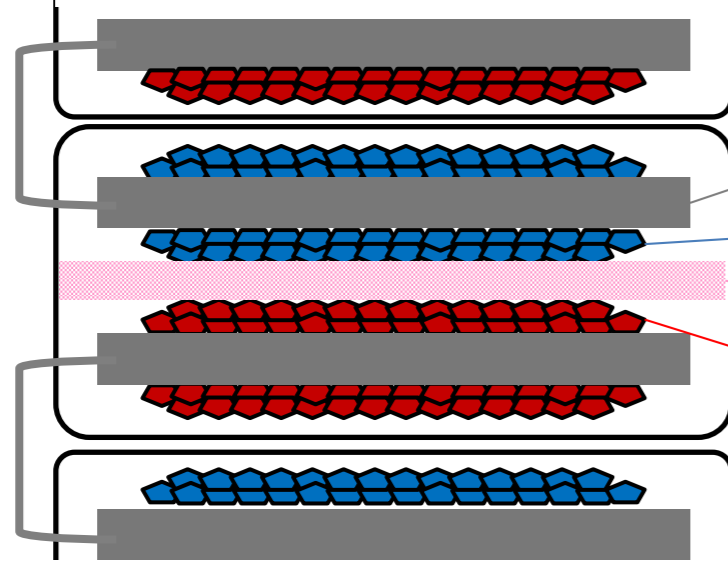

Current collector

Anode

Separator

Cathode

Case

Bipolar structure

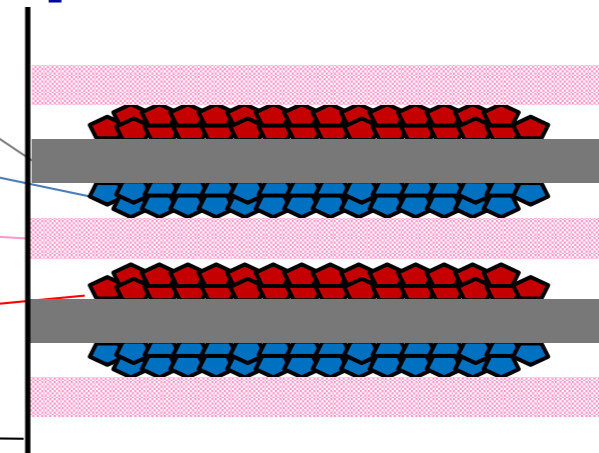

Taking up the challenge of innovating battery structure for more powerful acceleration

Next-generation BEVs

RAV4 L EV



RAV4 EV



C-HR / IZOA



TOYOTA bZ series

First model: Toyota bZ4X



A unique Toyota BEV that utilizes technology cultivated through years of HEV development

Battery cost targets: Integrated vehicle-battery development

Battery development

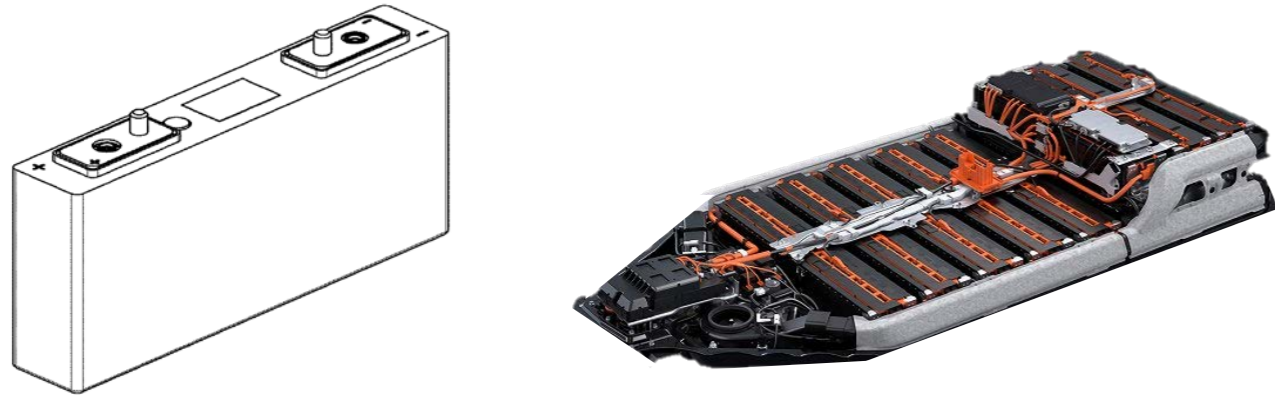

Greater than 30% reduction in cost of single battery

- Development of low-cost materials: cobalt-free, nickel-free, and new electrode materials
- Manufacturing process innovation: New development of battery manufacturing processes and battery material processes
- New structure: Integrated structure of battery cells and packs to match the vehicle
- Evolution of battery control model: Fuller use of battery capacity with focus on safety, security, and long service life

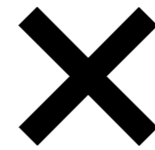

Vehicle development

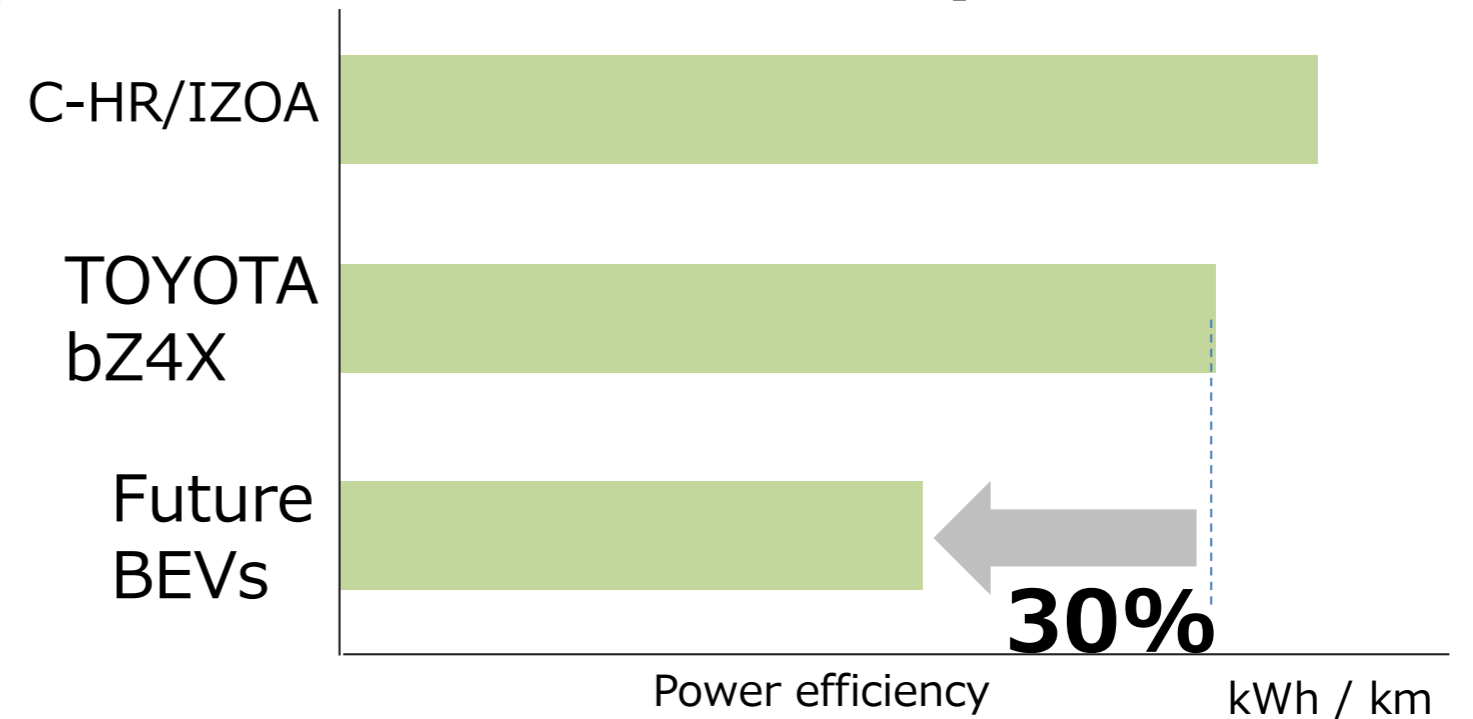

30% improvement in power efficiency = 30% reduction in battery capacity

(30% cost reduction)

Achieve the following by utilizing and developing technologies cultivated through 18.1 million electrified vehicles:

- Reduction of vehicle driving resistance to suit electrified vehicles
- Further expansion of energy regeneration
- Optimal energy/thermal management of entire vehicle and components
- Optimal efficiency design and control of entire powertrain system

Reducing cost by 30% by improving power efficiency and reducing cost of battery development by

30% ⇒ 50% reduction in battery costs (per vehicle)

-In the second half of 2020s

Next-generation lithium-ion battery

【Aims】

Longer service life

Greater energy density

More compact size

Lower cost

Evolution in liquid-based battery materials

Innovation in liquid battery structure

All-solid-state batteries

Composition

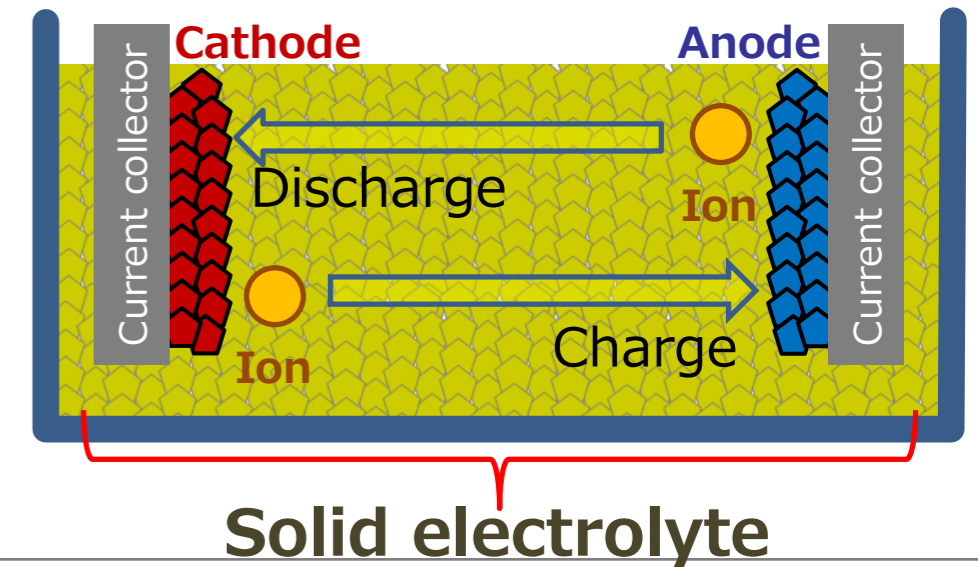
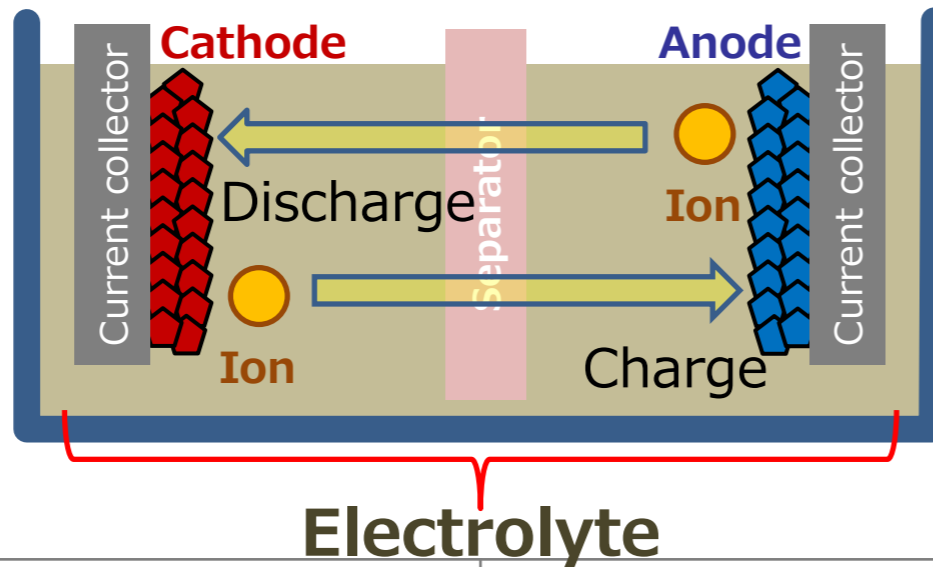

Structure



New structure



Taking on the challenge of developing a wide range of batteries for the second half of the 2020s
 Providing BEVs equipped with batteries with improved characteristics that enable driving with peace of mind

Characteristics of all-solid-state batteries

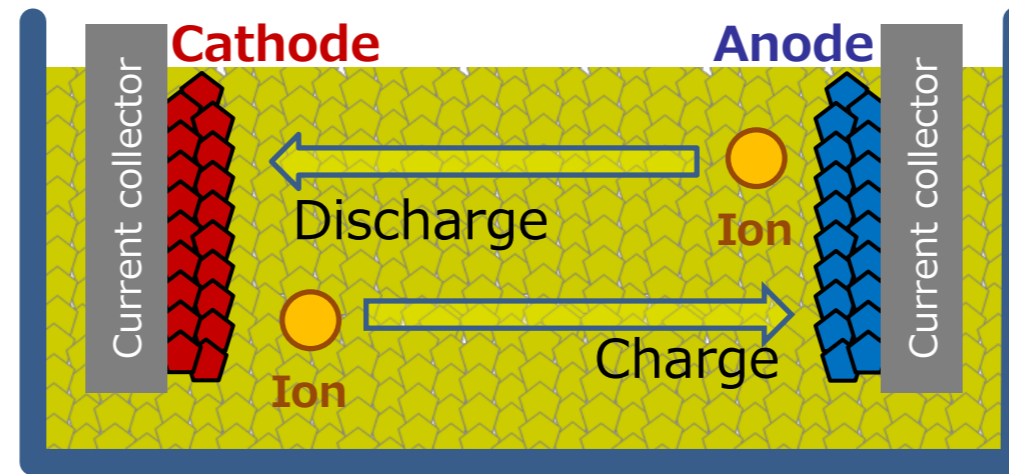

Solid electrolyte

Simple ion movement (fast)

High voltage tolerance

High temperature tolerance

High output

Long cruising range

Shorter charging time

Progress in development of all-solid-state batteries

June 2020



August 2020

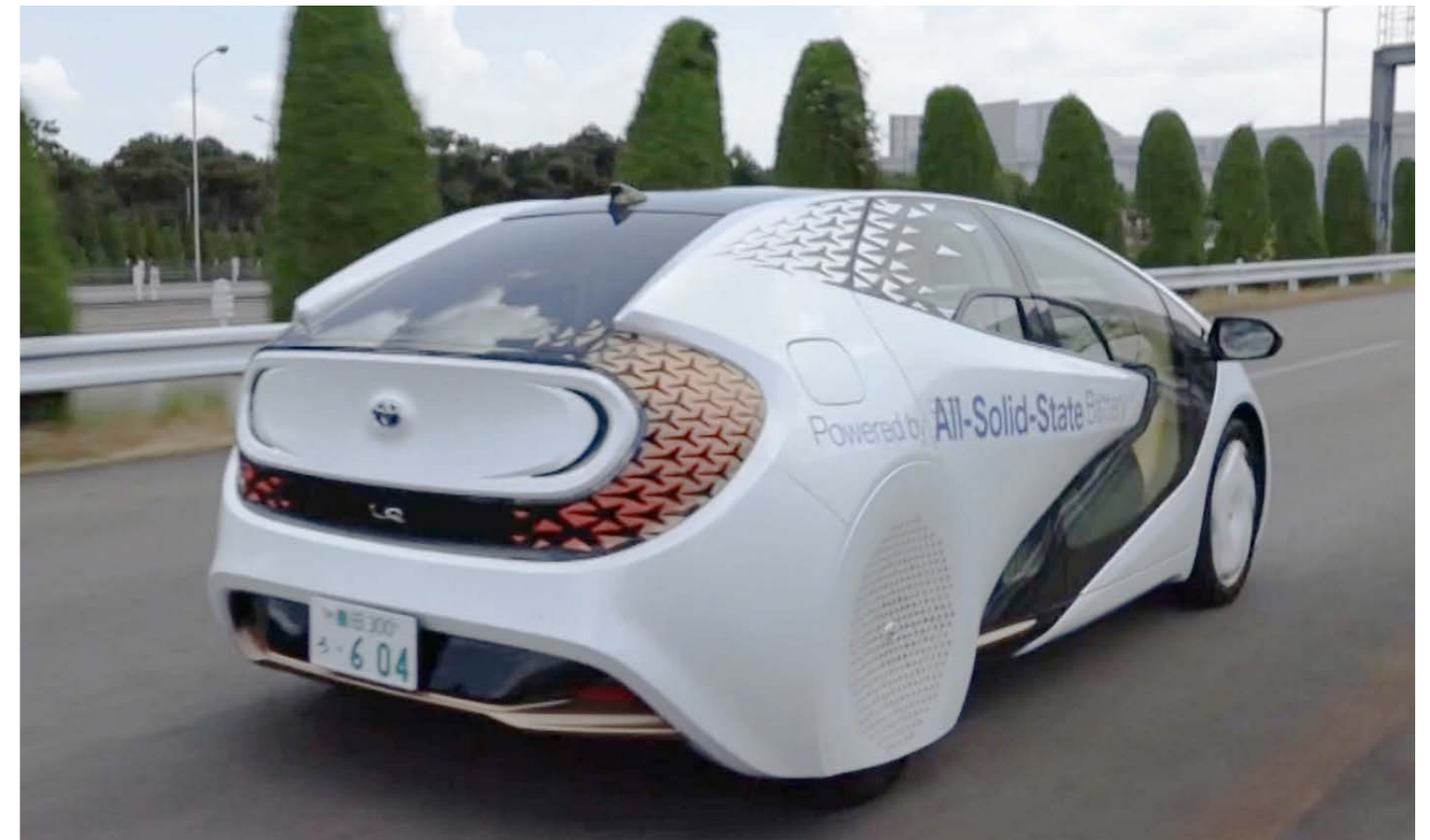

Obtained license plate registration in August 2020 and conducted test drives

- All-solid-state battery prototype vehicle built and driving data obtained
 - Now identifying the merits and challenges of use in vehicles

Future Development and Challenges of All-Solid-State Batteries

【Merits of all-solid-state batteries】

Simple ion movement (fast)

High voltage tolerance

High temperature tolerance

Early realization of use in HEVs

Utilizing ion speed for high-output batteries

Development of process for bonding solid materials

R&D for future use in BEVs

Key issue: Securing the service life of high-capacity batteries

Initial stages

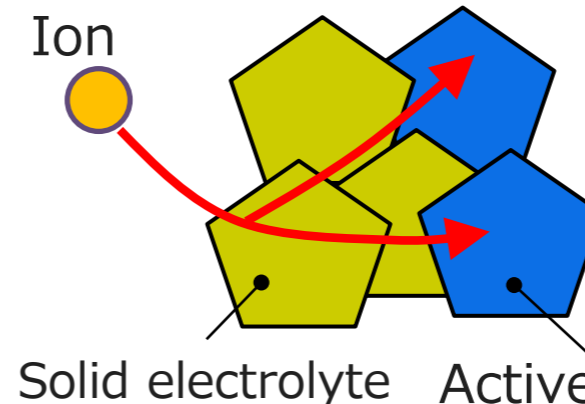

After long-term use

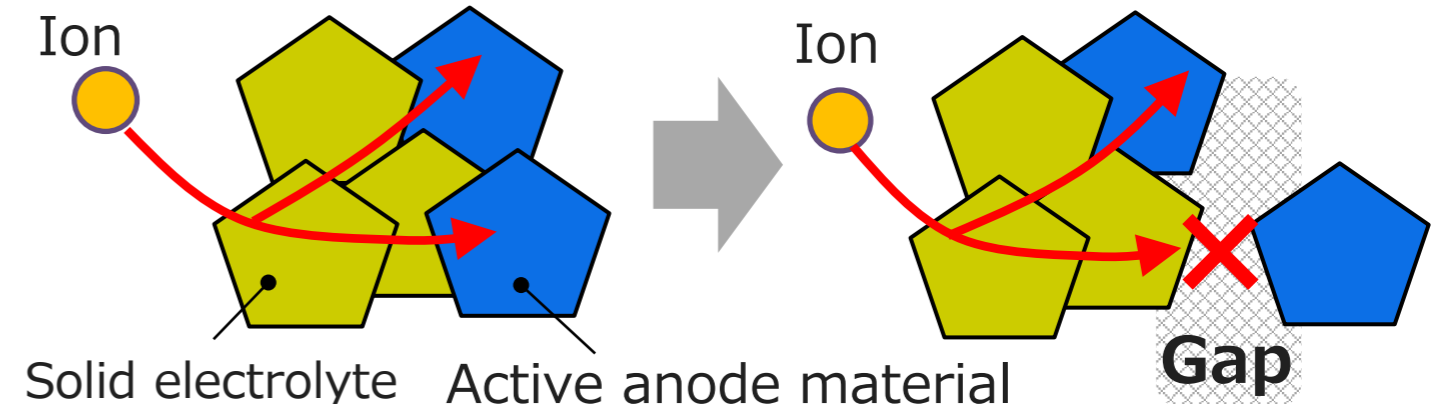

Now developing materials to reduce the occurrence of gaps

- First considering vehicles that utilize all-solid-state battery characteristics
- Overcoming challenges and envisioning rollout from HEVs to BEVs

Battery procurement and collaboration structure

CATL



弗迪電池
FinDreams Battery

BYD subsidiary.
Transferred relevant
project in 2021.



Panasonic

TOSHIBA

Future direction based on local conditions

- Strengthen collaboration with partners and consider new cooperative structures
- Rapid start-up of production within the Toyota Group

Toyota's battery strategy by 2030

Development

Cost reduction through integrated development of vehicles and batteries to provide reasonably priced vehicles

Target costs for future batteries

Aim for **50% reduction**
(per vehicle)

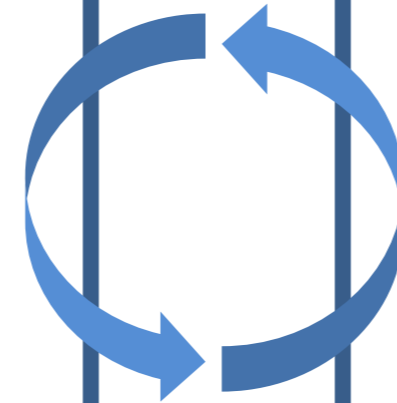

Investment
in batteries:
1.5 trillion yen

Supply

Build a flexible supply network and production system based on small basic units

Aiming to flexibly respond to increasing battery demand

More than
180GWh → **200GWh**

Spread of electrified vehicles, including BEVs

Sustainable & Practical



TOYOTA

SUSTAINABLE
DEVELOPMENT
GOALS