



US 20230103570A1

(19) **United States**

(12) **Patent Application Publication**
Mack et al.

(10) **Pub. No.: US 2023/0103570 A1**

(43) **Pub. Date: Apr. 6, 2023**

(54) **MOVABLE PANEL FOR A VEHICLE EXTERIOR**

(71) Applicant: **Rivian IP Holdings, LLC**, Plymouth, MI (US)

(72) Inventors: **Luke Mack**, Newport Beach, CA (US);
Jonathan Salerno, Newport, CA (US)

(21) Appl. No.: **17/494,140**

(22) Filed: **Oct. 5, 2021**

Publication Classification

(51) **Int. Cl.**
B60R 9/02 (2006.01)

(52) **U.S. Cl.**
CPC **B60R 9/02** (2013.01)

(57) **ABSTRACT**

A vehicle may have a vehicle exterior panel, which includes a rigid body defining at least in part a vehicle outer surface. A utility panel having an exterior surface and a generally planar utility surface may be movable with respect to the rigid body between a first position and a second position. The exterior surface is integrated into the vehicle outer surface and the utility surface is concealed at least partially within the vehicle outer surface when the utility panel is in the first position. The utility surface is deployed outwardly from the vehicle outer surface and positioned substantially horizontally when the utility panel is moved to the second position, with the utility panel extending from a support point of the rigid body such that the utility surface provides a work surface extending from the vehicle.

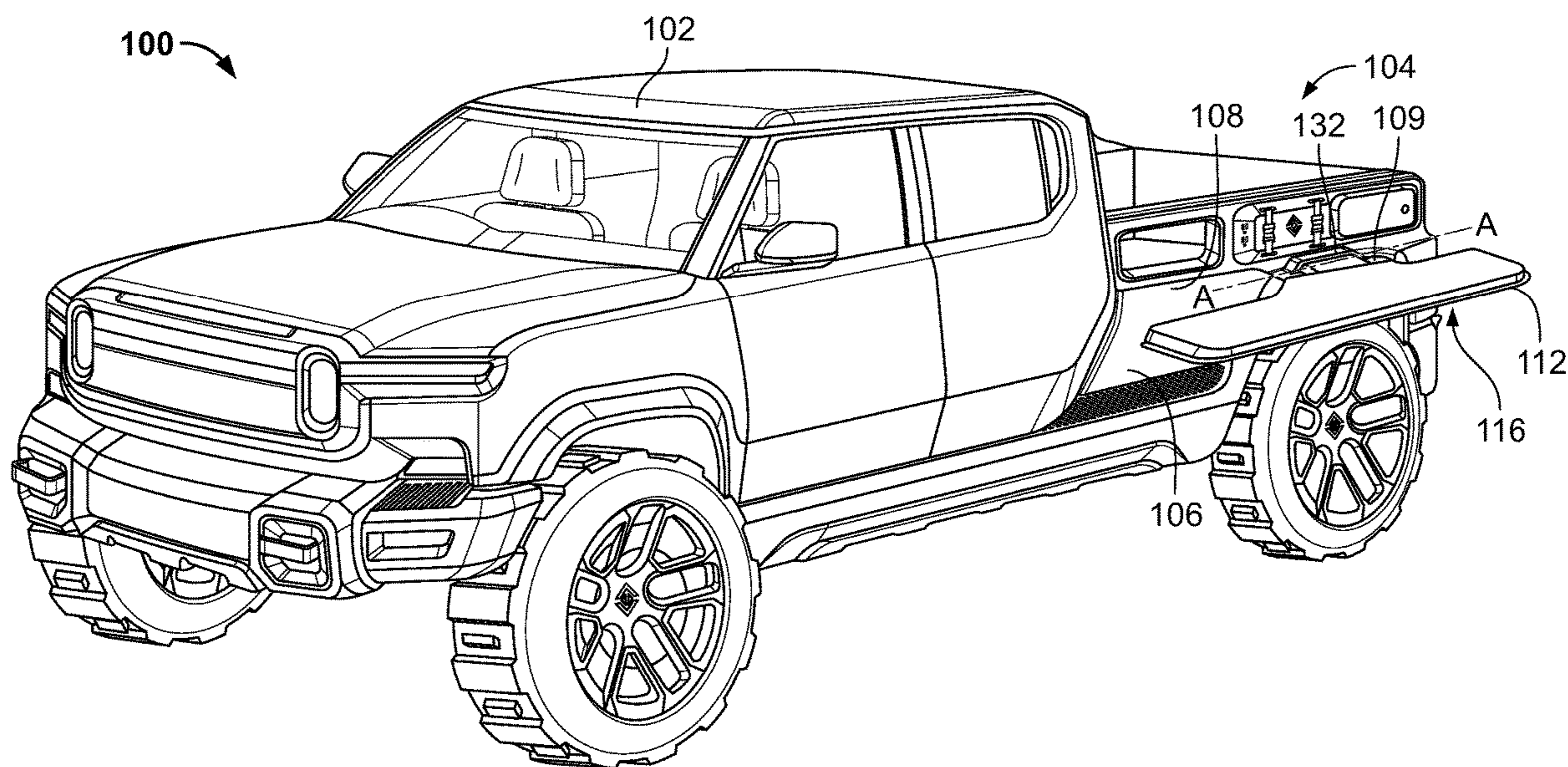

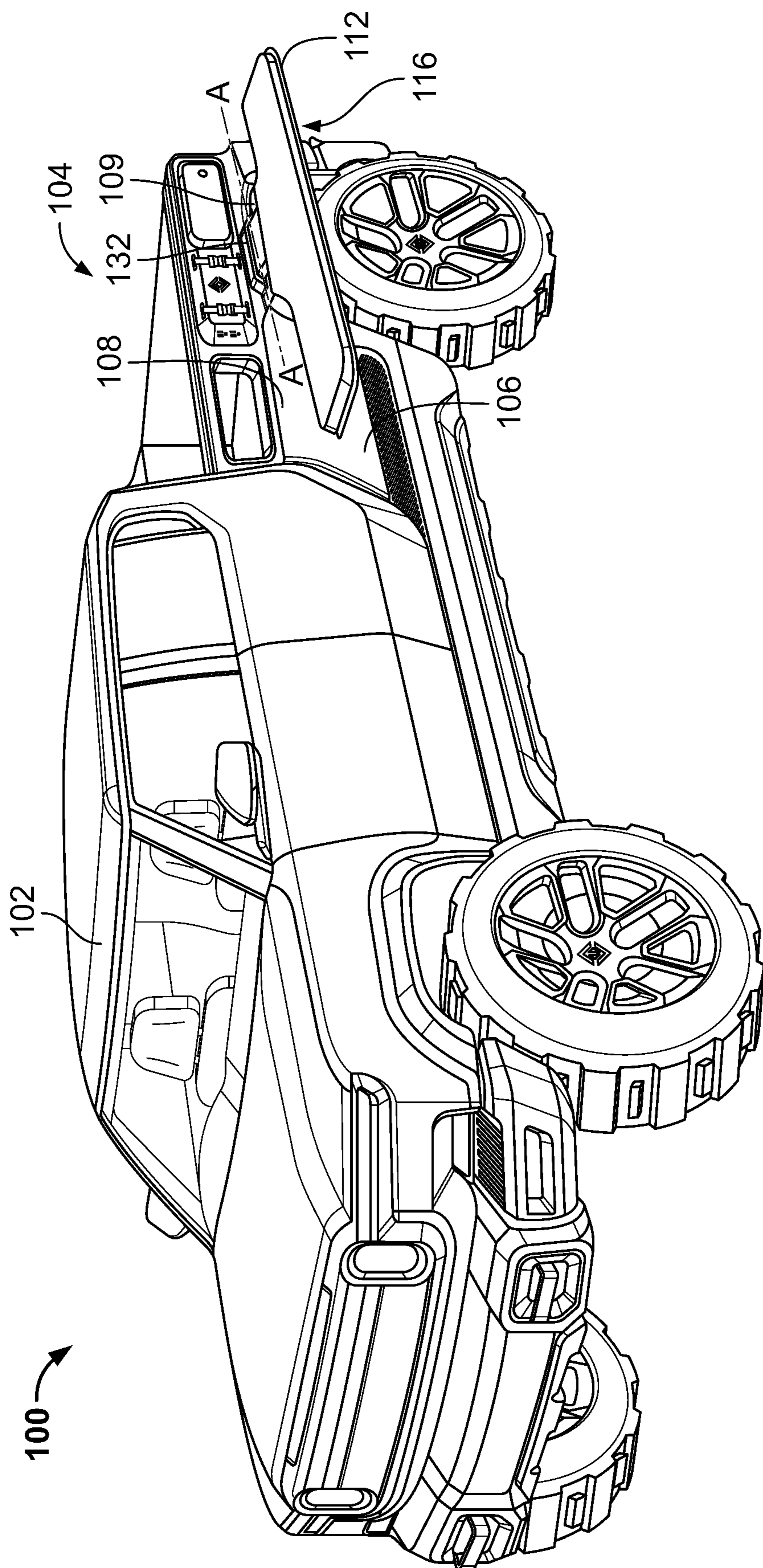

FIG. 1A

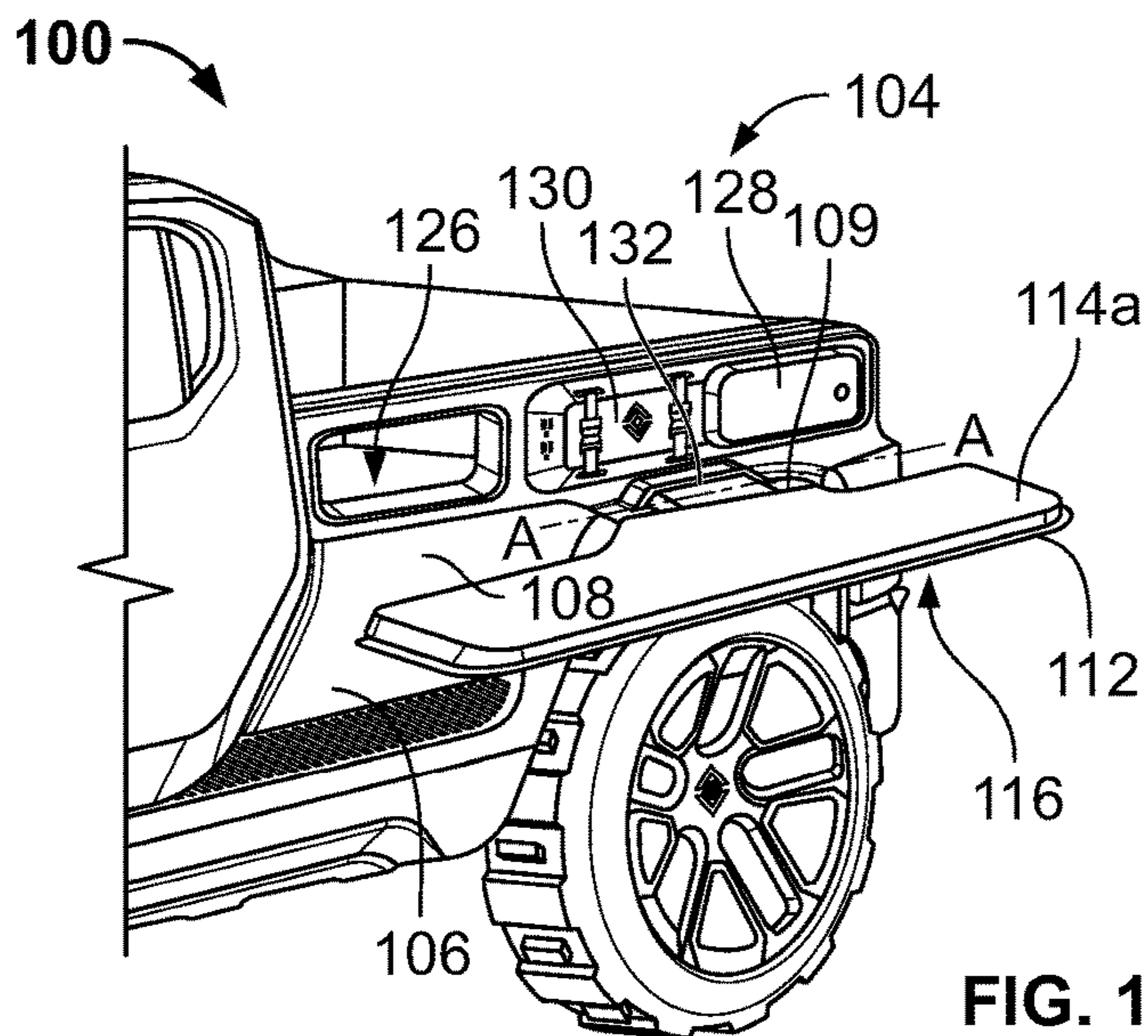

FIG. 1B

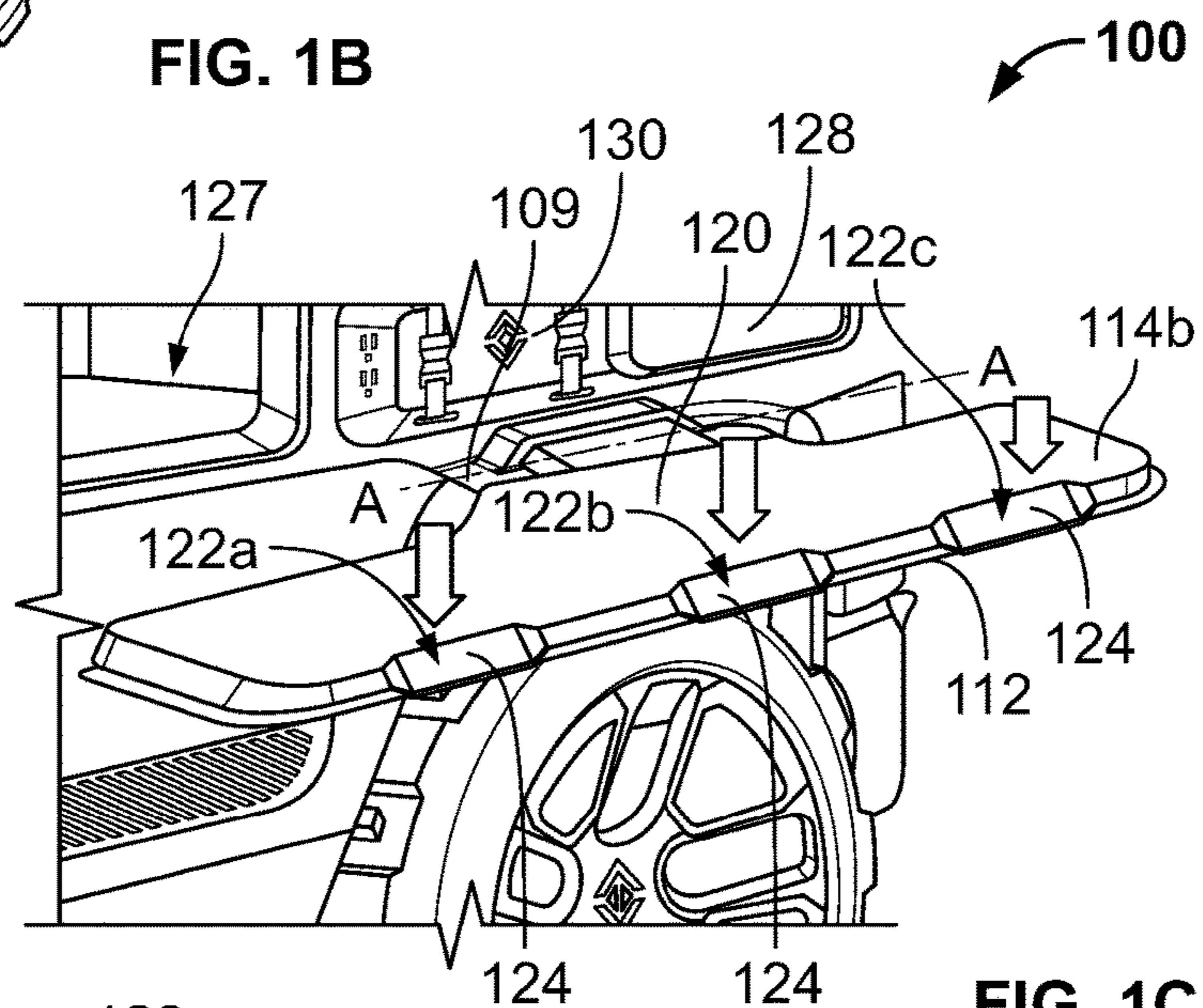

FIG. 1C

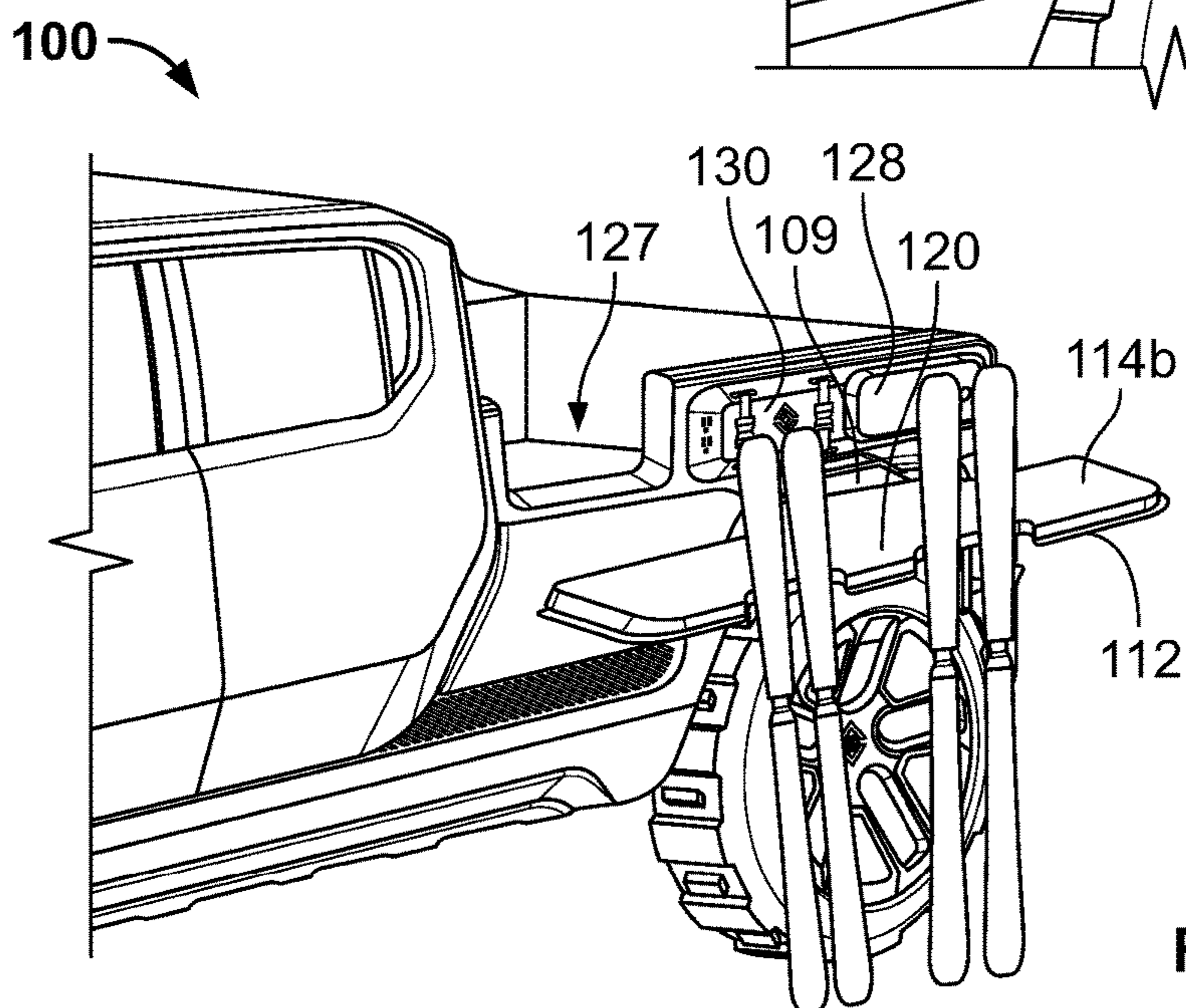

FIG. 1D

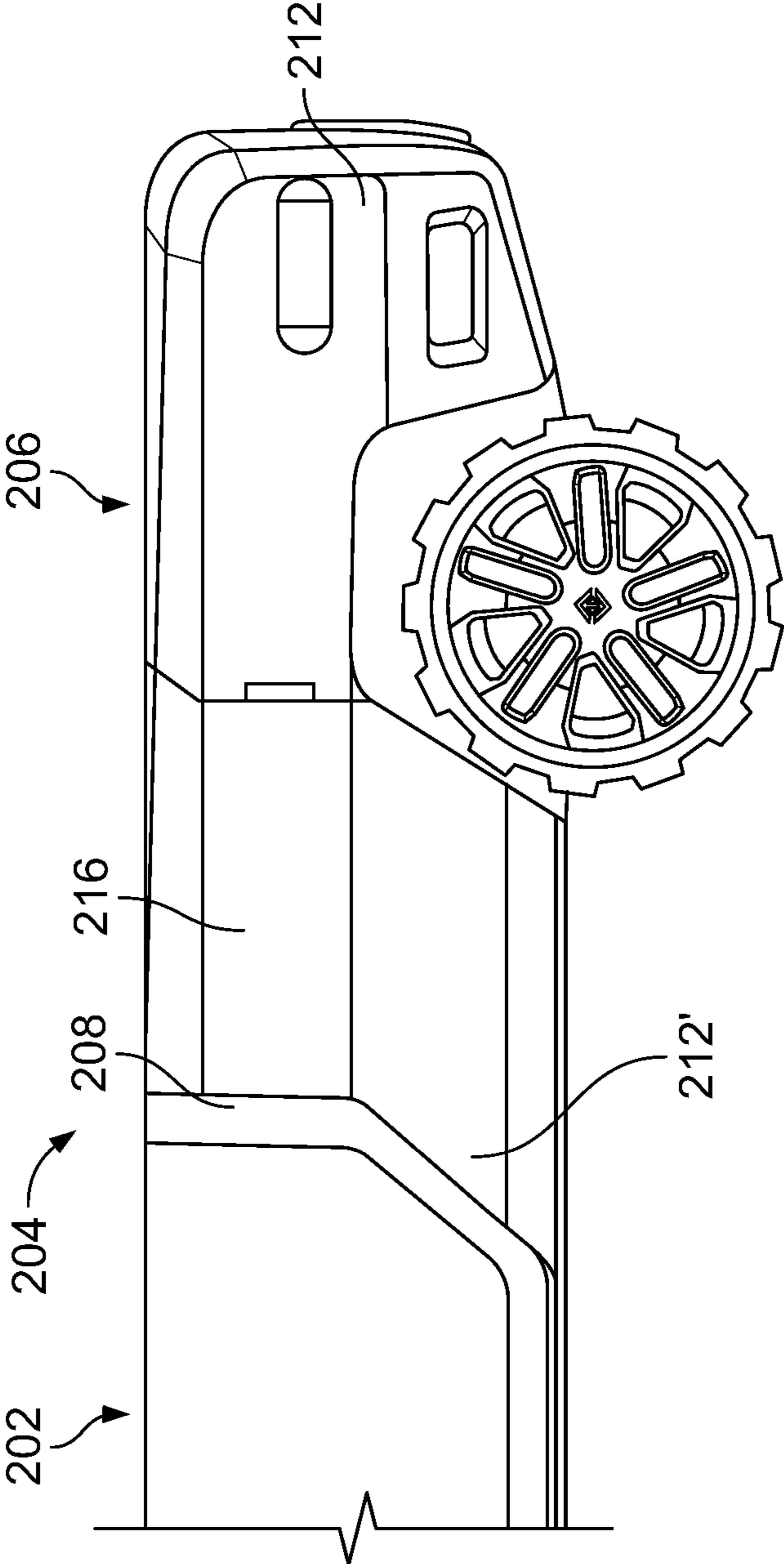

FIG. 2A

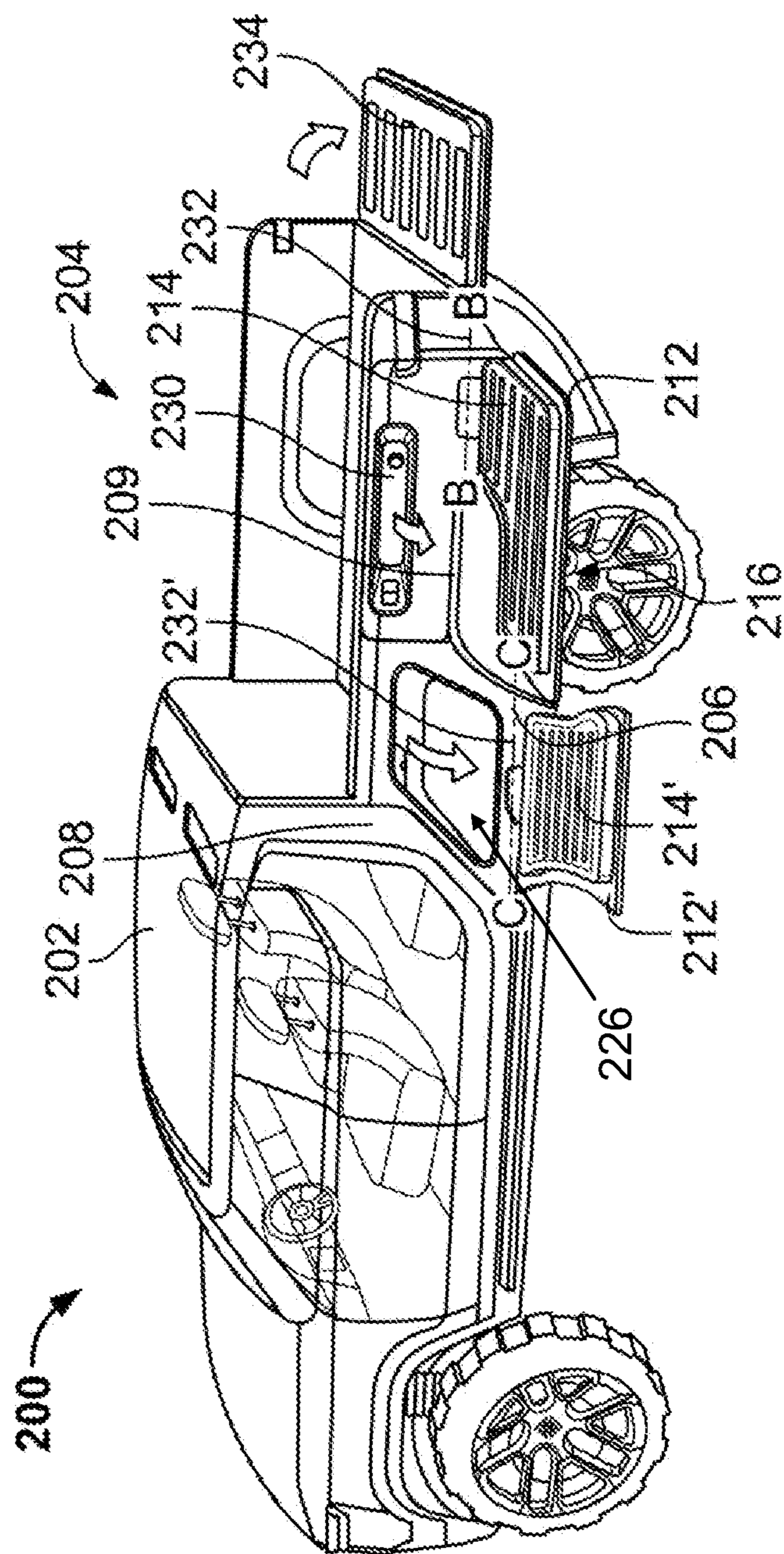

FIG. 2B

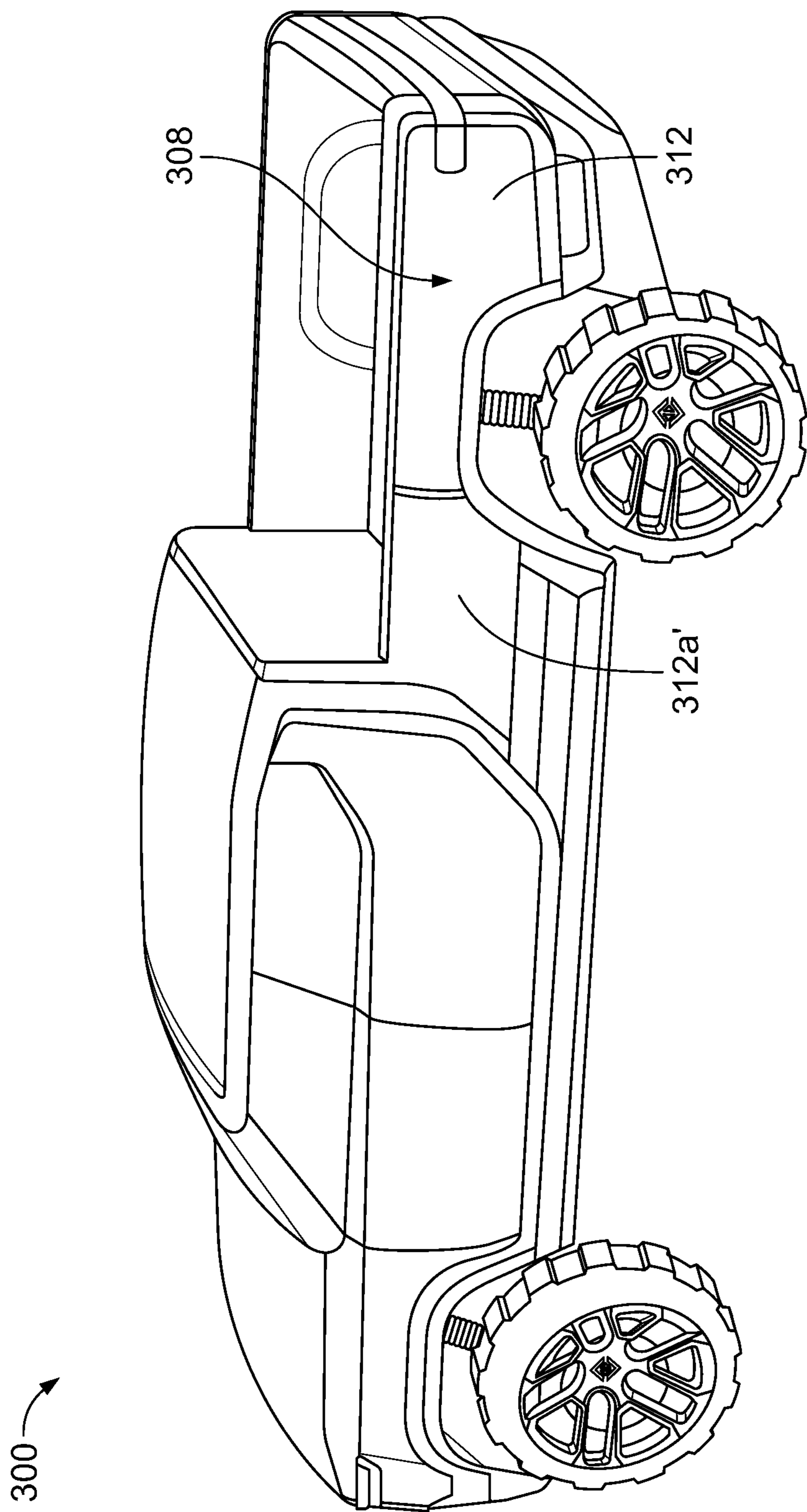

FIG. 3A

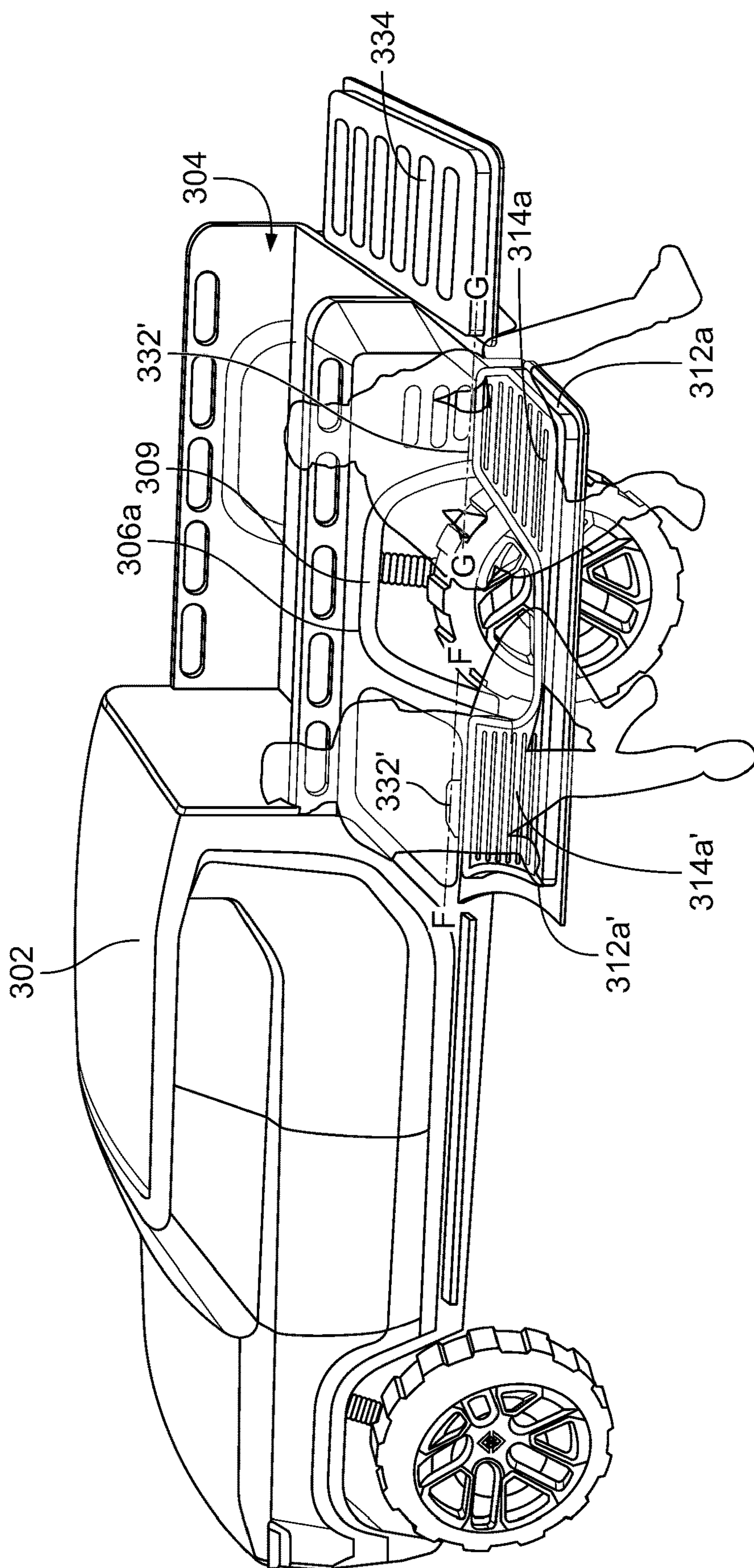

FIG. 3B

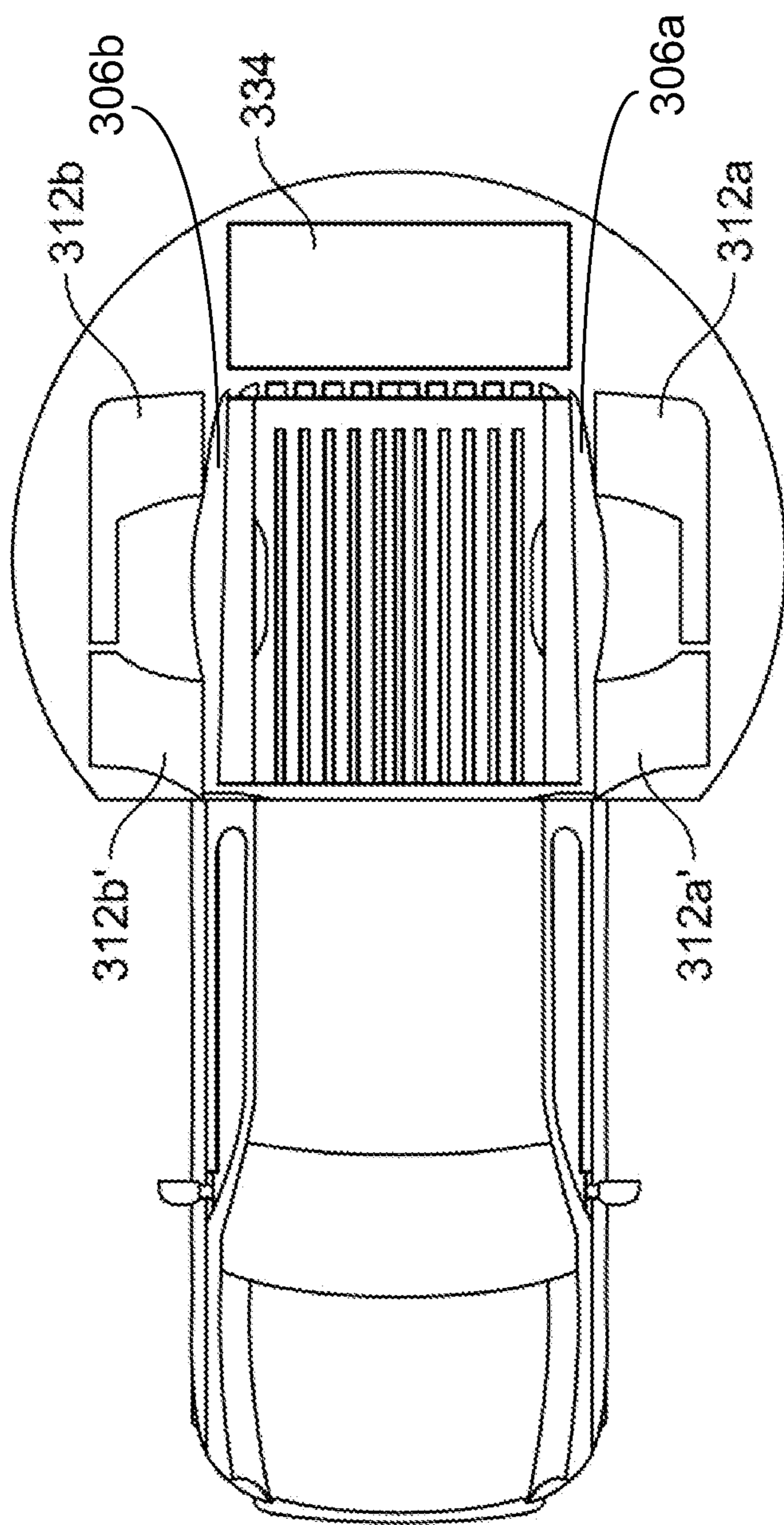

FIG. 3C

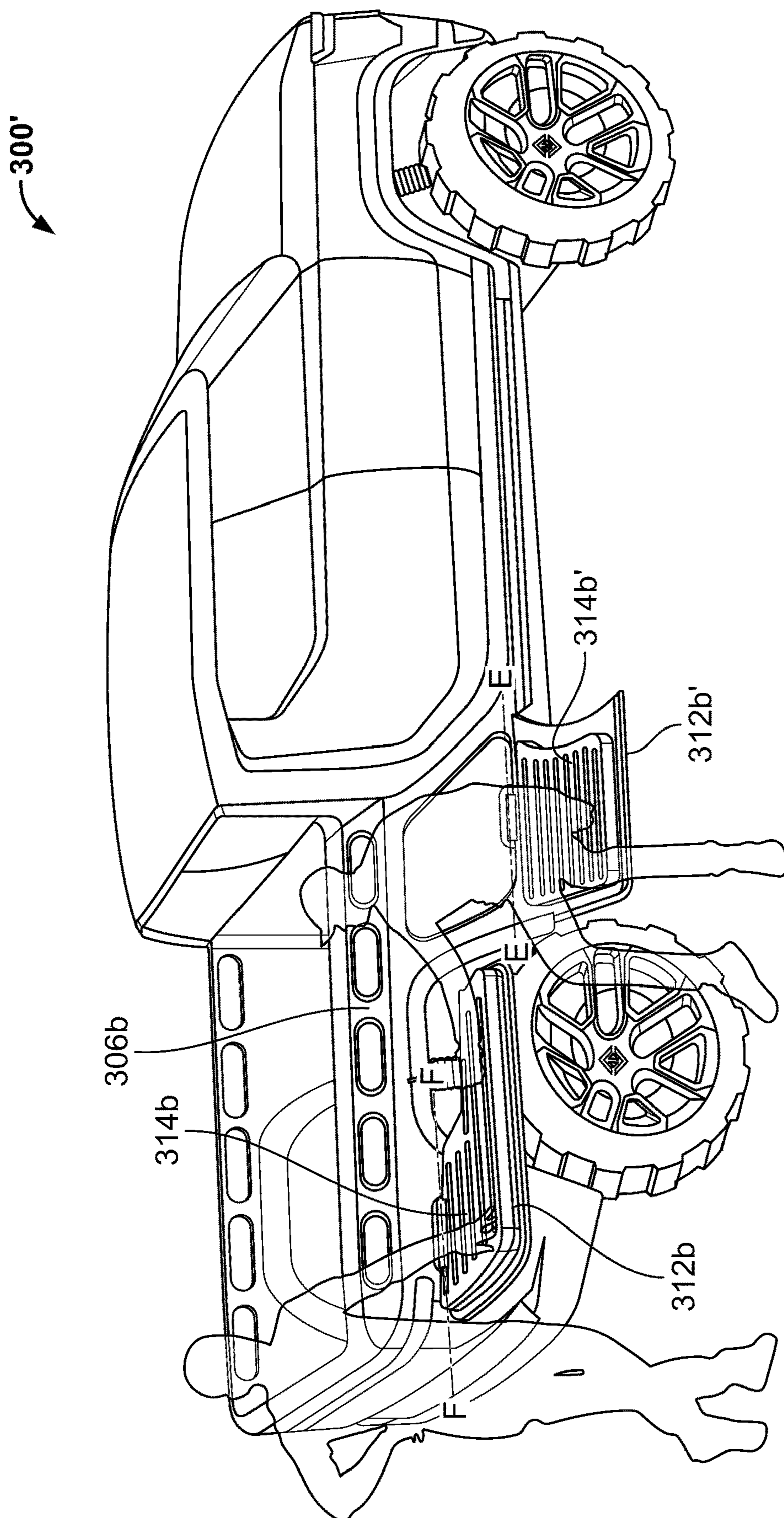

FIG. 3D

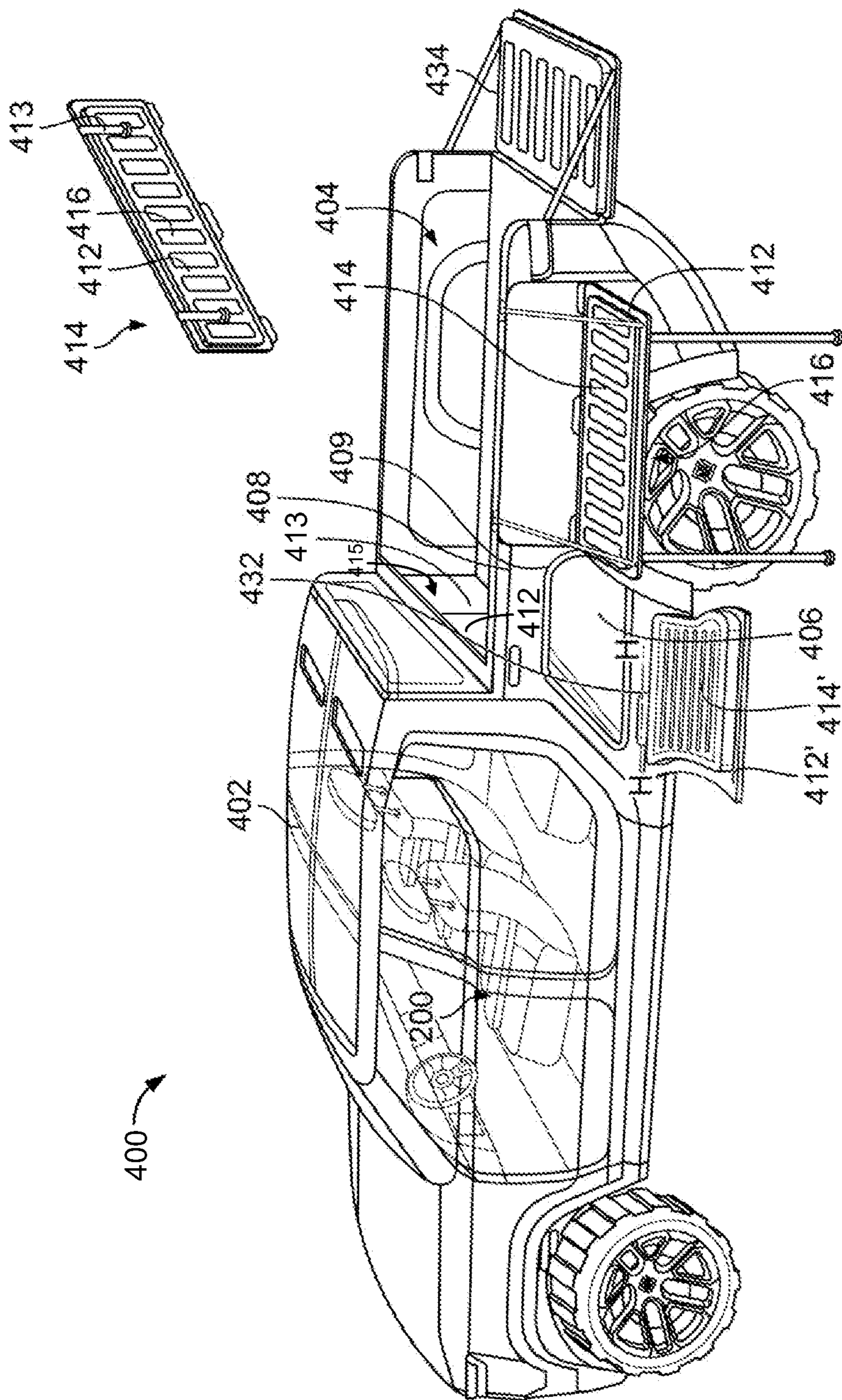

FIG. 4

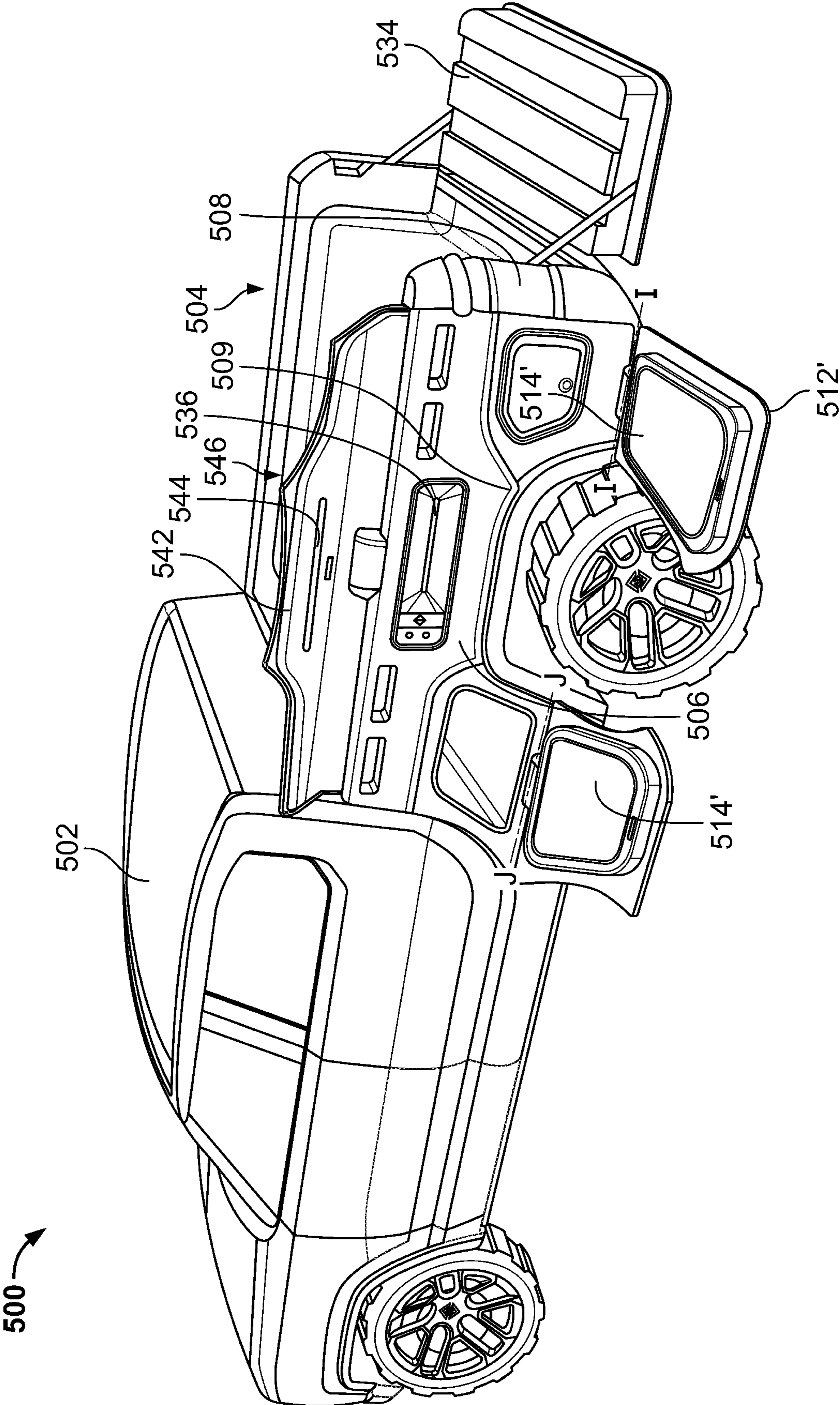

FIG. 5A

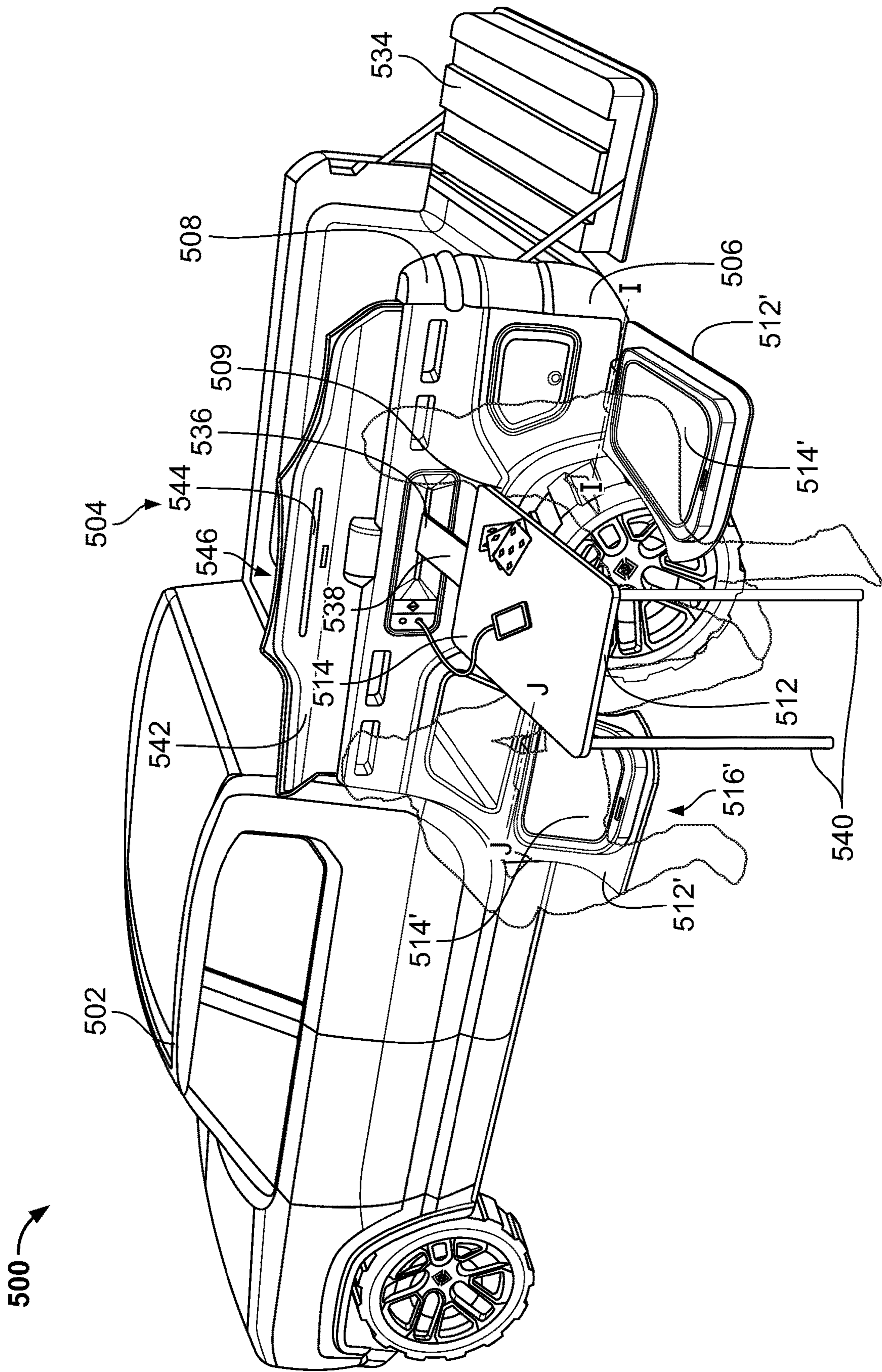

FIG. 5B

MOVABLE PANEL FOR A VEHICLE EXTERIOR

[0001] The present disclosure is directed to a movable panel structure for a vehicle exterior. More particularly, the present disclosure is directed to movable panel structure that provides a utility or work surface.

SUMMARY

[0002] Example approaches disclosed herein are generally directed to a vehicle exterior panel for a vehicle. In at least some example approaches, a vehicle exterior panel includes a rigid body defining at least in part a vehicle outer surface and a utility panel having an exterior surface and a generally planar utility surface. The utility panel may be movable with respect to the rigid body between a first position and a second position. The exterior surface is integrated into the vehicle outer surface and the utility surface is concealed at least partially within the vehicle outer surface when the utility panel is in the first position. The utility surface is deployed outwardly from the vehicle outer surface and positioned substantially horizontally when the utility panel is moved to the second position, with the utility panel extending from a support point of the rigid body such that the utility surface provides a work surface extending from the vehicle.

[0003] In at least some example illustrations, a vehicle includes a vehicle exterior panel having a rigid body defining at least in part a vehicle outer surface. The vehicle also includes a utility panel having an exterior surface and a generally planar utility surface. The utility panel is movable with respect to the rigid body between a first position and a second position. The exterior surface is integrated into the vehicle outer surface and the utility surface is concealed at least partially within the vehicle outer surface when the utility panel is in the first position. Further, the utility surface is deployed outwardly from the vehicle outer surface and positioned substantially horizontally when the utility panel is moved to the second position, with the utility panel extending from a support point of the rigid body such that the utility surface provides a work surface extending from the vehicle.

BRIEF DESCRIPTION OF THE DRAWINGS

[0004] The above and other features of the present disclosure, its nature and various advantages will be more apparent upon consideration of the following detailed description, taken in conjunction with the accompanying drawings in which:

[0005] FIG. 1A shows a front perspective view of an example vehicle having a utility panel, in accordance with one example illustration;

[0006] FIG. 1B shows an enlarged perspective view of a utility panel for the vehicle of FIG. 1A, in accordance with one example illustration;

[0007] FIG. 1C shows an enlarged perspective view of another utility panel for the vehicle of FIG. 1A, in accordance with an example illustration;

[0008] FIG. 1D shows another perspective view of the utility panel of FIG. 1C, in accordance with an example illustration;

[0009] FIG. 2A shows a side view of an example vehicle having multiple utility panels in a first or stowed position, in accordance with another example illustration;

[0010] FIG. 2B shows a rear perspective view of the vehicle of FIG. 2A with the utility panels in a second or deployed position, in accordance with an example;

[0011] FIG. 3A shows a side perspective view of a vehicle having utility panel(s) in a stowed position, in accordance with one example illustration;

[0012] FIG. 3B shows a driver-side perspective view of the vehicle of FIG. 3A with one or more utility panels in a deployed position, in accordance with one example illustration;

[0013] FIG. 3C shows a top view of the vehicle of FIGS. 3A-3B with one or more utility panels in a deployed position, in accordance with an example illustration;

[0014] FIG. 3D shows a passenger-side perspective view of a vehicle with one or more utility panels in a deployed position, in accordance with an example illustration;

[0015] FIG. 4 shows a side perspective view of an example vehicle having utility panel(s) in a deployed position, in accordance with another example;

[0016] FIG. 5A shows a driver-side perspective view of an example vehicle having utility panels in a deployed position, in accordance with another example; and

[0017] FIG. 5B shows a driver-side perspective view of the vehicle of FIG. 5A having utility panels in a deployed position, in accordance with another example.

DETAILED DESCRIPTION

[0018] The capability of off-road vehicles to reach remote destinations has increased, due in part to improved off-road traction, handling and/or improved range of such vehicles. As a result of this increased ability of off-road vehicles to reach remote destinations, there is a need for support systems that facilitate vehicle users staying in remote destinations.

[0019] Pickup truck vehicles typically have a liftgate that provides access to a rearward end of a cargo box. However, truck liftgates are generally low relative to a standing user, and as such would necessarily require the user to bend over the liftgate to use the liftgate as a work surface. Moreover, while truck beds generally provide ample space for hauling various items, preparation for using such items can result in a user setting or leaning such items against vehicle paint or other “show” surfaces of the vehicle, which risks damage to the vehicle.

[0020] Accordingly, example illustrations herein are directed to vehicles and exterior panels that provide one or more utility surfaces at a height that is convenient to a user for use as a work surface, i.e., to facilitate support of sufficient weight to allow the utility surface to be used as seating, a table, or for temporary storage of objects, or to lean objects against the utility surface, while not interrupting exterior design surfaces. Example utility surfaces may be defined by a utility panel that is movable with respect to a vehicle and/or vehicle exterior panel, e.g., by way of a pivoting mechanism such that the utility or work surface pivots with respect to a support point of a rigid body of the panel/vehicle. In other example approaches, a utility panel may be separable from a vehicle or vehicle panel, to allow the utility panel to be stowed within the vehicle or otherwise to conceal utility surface(s) defined by the utility panel. Example utility panels may thus provide utility as a table or work surface when needed, e.g., to support a user sitting on the surface, using as a table, etc., while not interrupting exterior design surfaces when stowed. In some example

approaches a utility panel is integrated into a vehicle exterior when in a stowed position, with an exterior surface of the utility panel following a surface contour of adjacent panel(s) of the vehicle. The utility panel(s) may define a cut line about a perimeter of the utility panel, allowing the entire utility panel to be moved, pivoted, removed, etc. with respect to the vehicle and/or exterior panel of the vehicle.

[0021] Example illustrations herein are directed to utility panels and other features on a driver side of a vehicle, a passenger side of a vehicle, or both sides of a vehicle. It should be understood that the features disclosed herein may be identical on both sides of a vehicle or included in combinations of features provided on a single side of a vehicle, without limitation. Additionally, while certain utility panels or other features may only be shown on one side of a vehicle, e.g., on a driver-side or a passenger-side of a vehicle, identical features may be provided on opposite or other sides of the vehicle.

[0022] Turning now to FIGS. 1A-1D, an example vehicle 100 is illustrated. While the vehicle 100 is illustrated as a pickup truck having a passenger cabin 102 and a cargo bed 104, example illustrations herein may be employed in the context of any other type of vehicle that is convenient, e.g., a sport-utility vehicle (SUV), sedan, etc.

[0023] The vehicle 100 includes a rear quarter panel 106, which generally defines a vehicle outer surface 108 along a side of the vehicle 100 toward the rear of the vehicle. While the driver's side of the vehicle 100 is illustrated, the opposite/passenger side of the vehicle 100 may be arranged identically as the driver's side, e.g., as a "mirror" reflection of the driver's side.

[0024] The quarter panel 106 is generally installed to the vehicle 100 as a rigid body defining the vehicle outer surface 108. The vehicle outer surface 108 is generally vertical along the quarter panel 106 in the vicinity of a utility panel 112. In the example illustrated in FIGS. 1A-1D, the utility panel 112 is pivotally mounted to the quarter panel 106 at a lower end of the utility panel 112. Accordingly, the utility panel 112 is movable between at least two positions relative to the quarter panel 106. In a first position, the utility panel 112 is generally in a stowed position where the utility panel 112 is integrated into the vehicle outer surface 108, while in a second position the utility panel 112 is deployed to protrude from the vehicle outer surface 108. More specifically, the utility panel 112 may be lowered from the first/stowed position to the second/deployed position. The deployed position of the utility panel generally exposes or makes available a utility surface 114 that is defined by the utility panel 112. On the other hand, the utility panel 112 may be placed in the stowed position while the vehicle 100 is being driven or there is otherwise no need for the utility panel 112 to be deployed. In the stowed position, the utility surface 114 is at least partially concealed, and an exterior surface 116 of the utility panel 112 is generally integrated with the vehicle outer surface 108, as will be discussed further below.

[0025] As shown in FIG. 1A, the utility surface 114 extends generally horizontally in the deployed position, and thus may be used as a work surface or table. It should be noted that the horizontally extending utility surface 114, when deployed as shown in FIG. 1A, is positioned vertically at a height that facilitates use as a table or other work surface by a user (not shown). For example, the relatively higher position of the deployed utility surface 114 allows use by a

user without requiring the user to bend or squat over the deployed utility surface 114. By comparison, a tailgate (not shown in FIGS. 1A-1D) of the cargo bed 104 may deploy to a relatively lower vertical position than the utility surface 114, as may be necessary to facilitate loading/unloading of objects to the cargo bed 104. In some examples, the utility surface 114 is deployed outwardly from the vehicle outer surface 108 and substantially horizontally when the utility panel 112 is placed in the second/deployed position. Further, as seen in FIG. 1A, the utility panel 112 is supported at the vehicle outer surface 108 above a wheel arch 109 defined by the quarter panel 106, and may fold down or pivot from a pivot point 132 with respect to the quarter panel 106 about an axis A-A.

[0026] Referring now to FIGS. 1B, 1C, and 1D, example utility surfaces 114a and 114b (collectively, 114) of the utility panel 112 in a deployed position are illustrated and described in further detail. In FIG. 1B, a first example utility surface 114a of the utility panel 112 is shown extending in a substantially continuous planar configuration. By contrast, in FIGS. 1C and 1D, the utility surface 114b includes a planar portion 120, as well as cavities 122a, 122b, and 122c (collectively, 122) of the utility panel 112. As shown in FIGS. 1C and 1D, the cavities 122 may be positioned along an uppermost edge of the utility panel 112. The cavities 122 each include an obliquely angled planar surface 124 that is configured to support leaning sports equipment, lumber, or any other objects tall enough to be leaned upon the deployed utility panel 112. In the example illustrated in FIG. 1D, pairs of skis are shown leaned against the utility panel 112 such that they are supported by the cavities 122. The cavities 122 generally retain an upper end of the skis therein, preventing the skis from tipping. Additionally, the cavities 122 may have a plastic or other surface that prevents damage to equipment positioned in contact with the cavities 122, such as the skis. Moreover, the cavities 122 also reduce or prevent damage to exterior surfaces of the vehicle 100, by reducing or eliminating the need to lean objects directly against the vehicle outer surface 108. Accordingly, cavities 122 generally allow for placement of an object against the vehicle 100, e.g., during unloading or loading of the vehicle 100.

[0027] The utility panel 112 may also facilitate storage within the quarter panel 106 or other functions. For example, as illustrated in FIG. 1B, deploying the utility panel 112 to the deployed/horizontal position may reveal an access port 126 to the cargo bed 104, which may allow access to the cargo bed 104 through the quarter panel 106. Additionally, a water storage container 128 may be provided in the quarter panel 106, and/or an accessory storage cavity 130, e.g., for a wireless speaker. The access port 126, water storage container 128, and accessory storage cavity 130 may each be concealed or covered up by the utility panel 112 when placed in the stowed position, as will be discussed further below. In the example illustrated in FIGS. 1C and 1D, an access notch 127 may be provided in an uppermost of the quarter panel 106, which may be revealed when the utility panel 112 is pivoted to the deployed position as shown. As best seen in FIG. 1D, the access notch 127 may allow an easier reach by a user into the cargo bed 104, e.g., by reducing the height over which a user may need to reach into the cargo bed 104, or may facilitate leaning of gear against the vehicle 100 in a similar manner as the cavities 122 of the utility panel 112. As with the example described above in FIG. 1B, the example utility panel 112 when deployed may reveal a water

storage container 128 provided in the quarter panel 106, and/or an accessory storage cavity 130, e.g., for a wireless speaker.

[0028] Turning now to FIGS. 2A and 2B, another example vehicle 200 is illustrated and described in further detail, which includes multiple utility panels that are movable at various positions about the vehicle. The vehicle 200 includes a passenger cabin 202 positioned in front of a cargo bed 204. The cargo bed 204 is defined in part by a quarter panel 206 along a rearward end of the vehicle 200. The quarter panel 206 is a generally rigid body defining a vehicle outer surface 208. The vehicle outer surface 208 is generally vertical along the quarter panel 206 in the vicinity of a utility panel 212, which is illustrated in a stowed or first position in FIG. 2A, and a deployed or second position in FIG. 2B. The example utility panel 212 illustrated in FIGS. 2A and 2B is pivotally mounted to the quarter panel 206 for movement between the first and second positions. For example, as best seen in FIG. 2B the utility panel 212 may be supported at the vehicle outer surface 208 above a wheel arch 209 defined by the quarter panel 206, and may fold down or pivot from a pivot point 232 with respect to the quarter panel 106 about an axis B-B. The utility panel 212 is generally integrated into the vehicle outer surface 208 when in the stowed position of FIG. 2A. By contrast, the utility panel 212 may be pivoted to the second/deployed position, in which it protrudes from the vehicle outer surface 208 as seen in FIG. 2B. The deployed position of the utility panel generally exposes a utility surface 214 that is defined by the utility panel 212. When the utility panel 212 is in the stowed position, the utility surface 214 is at least partially concealed, and an exterior surface 216 of the utility panel 112 is generally integrated with the vehicle outer surface 208.

[0029] As best seen in FIG. 2B, the utility surface 214 extends generally horizontally in the deployed position, and thus may be used as a work surface or table. As with the example utility surface 114 illustrated in FIGS. 1A-1D, the horizontally extending utility surface 214 is positioned vertically with respect to the vehicle 200 at a height that facilitates use as a table or other work surface by a user (not shown). For example, the relatively high position of the deployed utility surface 214 allows use by a user without requiring the user to bend or squat over the deployed utility surface 214. By comparison, a tailgate 234 of the cargo box 204, as seen in FIG. 2B, deploys to a relatively lower vertical position than the utility surface 214. In the example illustrated in FIG. 2B, the deployed utility surface 514 is positioned above a wheel arch 209 of the vehicle 200 and/or quarter panel 206.

[0030] The utility panel 212 may also facilitate storage within the quarter panel 206 or other functions. For example, as illustrated in FIG. 2B, deploying the utility panel 212 to the deployed/horizontal position may reveal an accessory storage cavity 230, which may be used to store water or other liquids in a container, accessories such as a wireless speaker, etc. The accessory storage cavity 230 may generally be concealed or covered up by the utility panel 212 when placed in the stowed position, as will be discussed further below. The utility surface 214 of the utility panel 212 is shown extending in a substantially continuous planar configuration, as may be useful as a table or work surface.

[0031] The vehicle 200 also includes a second utility panel 212' positioned adjacent the utility panel 212. The utility panel 212' similarly pivots from a first position illustrated in

FIG. 2A to a second position illustrated in FIG. 2B. The utility panel 212' is supported at the vehicle outer surface 208, and may fold down or pivot from a pivot point 232' with respect to the quarter panel 206 about an axis C-C. In the first or stowed position, an exterior surface 216' of the utility panel 212' is integrated into the exterior surface 208 of the quarter panel, as with the exterior surface 216 of the utility panel 212. In the second position illustrated in FIG. 2B, a utility surface 214' of the utility panel 212' extends horizontally, similar to the utility surface 214 of the utility panel 212. However, the utility surface 214' is relatively lower vertically than the utility surface 214, facilitating use of the utility surface 214' as a chair or seat next to utility surface 214, which may be utilized as a table. Moreover, the utility panel 212' is configured to support the weight of a user for sitting upon the utility surface 214', e.g., as a result of additional support or members supporting the utility panel 212' in the deployed position. Alternatively or in addition, pivoting the utility panel 212' to the deployed/horizontal position may expose an access port 226, which opens into the cargo bed 204 or other storage compartment.

[0032] Turning now to FIGS. 3A-3D, example vehicles 300 and 300' are shown having multiple utility panels positioned about an exterior of the vehicle 300. More specifically, in the example illustrated in FIGS. 3A-3C, vehicle 300 is shown with seating provided about three sides (i.e., 270 degrees) of the vehicle 300, while in FIG. 3D another example vehicle 300' is shown having a seating and table arrangement. Vehicle 300 includes a passenger cabin 302 positioned in front of a cargo bed 304. Quarter panels 306a, 306b (collectively, 306) extend along driver and passenger sides, respectively, of a cargo bed 304 toward a rearward end of the vehicle 300. The quarter panels 306 are each a generally rigid body defining a vehicle outer surface 308. The vehicle outer surfaces 308 of each quarter panel 306 are generally vertical along the quarter panel 306. Each of the quarter panels 306a, 306b respectively includes a first utility panel 312a, 312b, which is illustrated in a stowed or first position in FIG. 3A, and a deployed or second position in FIGS. 3B and 3C. The example utility panels 312 illustrated in FIGS. 3A-3C are each pivotally mounted to their respective quarter panel 306 for movement between the first and second positions. As best seen in FIG. 3B, the utility panel 312a and 312a' each fold down or pivot from pivot points 332 and 332' about axes F-F and G-G, respectively. Similarly, the utility panels 312b and 312b' may fold down from respective pivots points and axes, e.g., as discussed further below. The utility panels 312 are each generally integrated into the vehicle outer surface 308 when in the stowed position of FIG. 3A. By contrast, the utility panels 312 may be pivoted to the second/deployed position, in which it protrudes from the vehicle outer surface 308 as seen in FIGS. 3B and 3C. The deployed position of the utility panels generally exposes respective utility surfaces 314a, 314b. When the utility panels 312 are in the stowed position, the respective utility surface 314 is at least partially concealed, and an exterior surface 316 of the utility panel 312 is generally integrated with the vehicle outer surface 308.

[0033] As best seen in FIGS. 3B-3D, the utility surfaces 314a, 314b of the vehicles 300, 300' each extend generally horizontally in the deployed position. The passenger-side utility surface 314b of the vehicle 300' in FIG. 3D is generally elevated with respect to a tailgate surface 334, with the deployed utility surface 314 being positioned above

a wheel arch **309** of the vehicle **300** and/or quarter panel **306**. The utility panel **312b** folds down or pivots from a pivot point **332"**, about an axis D-D. The utility surface **314a** and **314b** each also extend along a greater length of the vehicle **300** longitudinally than with other example utility panels, e.g., extending longitudinally from a position behind the wheel arch **309** to a position above the wheel arch **309**. Additionally, the utility surfaces **314a'** and **314a** may cooperate to form a generally continuous surface, e.g., which may be used as a bench as illustrated in FIG. 3A that extends the length of the cargo area **304**. While the utility surfaces **314a**, **314a'** and respective utility panels **312a**, **312a'** are illustrated as being two separately pivoting components, in some examples the utility panels **312a**, **312a'** may be provided as a single monolithic piece configured to pivot with respect to the cargo area **304**. The driver-side utility surface **314a** is positioned relatively lower, e.g., at a vertical height with respect to the vehicle **300** that is approximately the same as the tailgate surface **334** as shown. The vehicle **300** also includes a pair of second utility panels **312a'**, **312b'** (collectively, **312'**) that are positioned adjacent their respective utility panels **312a**, **312b**. Each of the utility panels **312'** similarly pivot from a first position illustrated in FIG. 3A to a second position illustrated in FIGS. 3B-3D. In the first or stowed position, an exterior surface **316'** of each utility panel **312'** is integrated into the exterior surface **308**. In the second position best seen in FIG. 3D, a utility surface **314b'** of the utility panel **312b'** extends horizontally, and is relatively lower vertically than the adjacent utility surface **314b**, facilitating use of the utility surface **314b'** as a chair or seat next to utility surface **314b**, which may be utilized as a table. Additionally, the utility panel **312b'** may be configured to support the weight of a user to facilitate use of the utility surface **314b'** as a seat or chair adjacent the table. One or more of the utility panels **312** may also facilitate storage within its respective quarter panel **306**, e.g., as similarly described above with reference to FIGS. 1 and 2, or other functions.

[0034] As noted above, in the example vehicle **300'** illustrated in FIG. 3D, one utility panel **312b** pivots about an axis D-D which is elevated with respect to a pivot axis E-E of another utility panel **312b'**. Accordingly, when deployed as shown in FIG. 3D, the utility surface **314b** serves as a table surface that is elevated with respect to the utility surface **314b'** of the adjacent utility panel **312b'**.

[0035] Turning now to FIG. 4, another example vehicle **400** is illustrated and described in further detail. As with the above described vehicles **100**, **200** and **300**, the vehicle **400** includes a passenger cabin **402** positioned in front of a cargo bed **404**. The cargo bed **404** is defined in part by a quarter panel **406** along a rearward end of the vehicle **400**. The quarter panel **406** is a generally rigid body defining a vehicle outer surface **408**. The vehicle outer surface **408** is generally vertical along the quarter panel **406**. A deployable utility panel **412** is provided, which is selectively mountable to the quarter panel **406**. More specifically, in contrast to the pivotable arrangement of other utility panels described above, the utility panel **412** is separable from the vehicle **400**. In a first position, the utility panel **412** may be mounted within the cargo bed **404** of the vehicle **400**. More specifically, the utility panel **412** may form a forward surface **415** of the cargo bed **404**, adjacent the passenger cabin **402**. The utility panel **412** may be positioned within the cargo bed **404** in any manner convenient. While the forward surface **415** is

shown at a forward end of the cargo bed **404**, in other examples the utility panel **412** may be positioned or stowed in different areas of the cargo area **404**, e.g., by integrating or storing in the tailgate **434** at a rearward end of the cargo area **404**, along a side of the cargo area **404**, etc. Moreover, the utility panel **412** may in still other examples be positioned elsewhere within the cargo area **404**, e.g., to divide the cargo area **404** into separate storage areas. The utility panel **412** may be removed from the stowed position and mounted in a horizontal position to the quarter panel **406**. When mounted to the quarter panel **406**, the utility panel **412** protrudes horizontally from the vehicle outer surface **408**. The deployed position of the utility panel **412** generally provides a utility surface **414** that is defined by the utility panel **412**. By contrast, when the utility panel **412** is mounted within the cargo bed **404**, the utility surface **414** is at least partially concealed. Accordingly, the utility panel **412** does not disrupt exterior surface **408** of the vehicle **400**. In some examples, a utility panel is divided into two separate pieces, e.g., into a first utility panel **412** and a second utility panel **413** as illustrated in FIG. 4. In the example illustrated, the second utility panel **413** may also be mounted within the cargo bed **404**, cooperating with the utility panel **412** to form forward surface **415** of the cargo bed **404**. The second utility panel **413** may be removable from the cargo bed **404** or otherwise separable from the vehicle **400**, and may be mounted in a passenger side quarter panel of the vehicle **400** in substantially mirror-image fashion with respect to the utility panel **412** described above, i.e., along the passenger-side of the vehicle. While the utility panels **412** and **413** are shown as separate pieces, in some examples they may be a single monolithic piece that can be deployed from two or more support points to extend away from the vehicle surface **408**.

[0036] The utility surface **414** of the utility panel **412** extends generally horizontally in the deployed position, as shown in FIG. 4, and thus may be used as a work surface or table. Similar to other examples described above, the horizontally extending utility surface **414** is positioned vertically with respect to the vehicle **400** at a height that facilitates use as a table or other work surface by a user (not shown). In the example illustrated in FIG. 4, the deployed utility surface **414** is positioned above a wheel arch **409** of the vehicle **400** and/or quarter panel **406**. The relatively higher position of the deployed utility surface **414** allows use by a user generally without requiring the user to bend or squat over the deployed utility surface **414**. By comparison, a tailgate **434** of the cargo box **404**, deploys to a relatively lower vertical position than the utility surface **414**.

[0037] The vehicle **400** also includes an additional utility panel **412'** positioned adjacent the deployed utility panel **412**. The utility panel **412'** is supported at the vehicle outer surface **408**, and may fold down or pivot from a pivot point **432** with respect to the quarter panel **406** about an axis H-H. The utility panel **412'**, in contrast to the removable utility panel **412**, generally pivots between a stowed position (not shown in FIG. 4) and a deployed position. In the first or stowed position, an exterior surface (not shown in FIG. 4) of the utility panel **412'** is integrated into the exterior surface **408** of the quarter panel, as with other example utility panels described herein. In the deployed position illustrated in FIG. 4, a utility surface **414'** of the utility panel **412'** extends horizontally, similar to the utility surface **414** of the utility panel **412**. However, the utility surface **414'** is relatively

lower vertically than the deployed utility surface **414**, facilitating use of the utility surface **414'** as a chair or seat next to utility surface **414**, which may be utilized as a table. Alternatively or in addition, pivoting the utility panel **412'** to the deployed/horizontal position may expose an access port (not shown in FIG. 4) that allows access to the cargo bed **404** or other cargo cavity (not shown) through the quarter panel **406**.

[0038] Turning now to FIGS. 5A and 5B, another example vehicle **500** is illustrated and described in further detail. As with the above described vehicles **100**, **200**, **300**, and **400**, the vehicle **500** includes a passenger cabin **502** positioned in front of a cargo bed **504**. The cargo bed **504** is defined in part by quarter panels **506** on either side of the cargo bed **504** along a rearward end of the vehicle **500**. A tailgate **534** provides access to the cargo bed **504** from the rear of the vehicle **500**.

[0039] The quarter panels **506** are each a generally rigid body defining a vehicle outer surface **508**. The vehicle outer surface **508** is generally vertical along the quarter panel **506**. One or more deployable utility panel(s) **512** may be provided, which are configured to be mounted to either quarter panel **506**, for example as illustrated in FIG. 5B. When mounted to the quarter panel **506**, the utility panel(s) **512** may extend from the vehicle **500** in a generally horizontal position. For example, as shown in FIG. 5B, a longitudinally extending slot or cavity **536** of the quarter panel **506** may receive a panel tab **538**, allowing utility panel **512** to be supported along an edge of the utility panel **512**. Legs **540** may also be provided to support an end of the utility panel **512** away from the vehicle **500**, thereby adding additional support and increasing the ability of a utility surface **514** of the panel **512** to bear weight, e.g., as a table or work surface. The deployed position of the utility panel **512** generally positions the utility surface **514** for use as a table or work surface. As best seen in FIG. 5B, the utility surface **514** is elevated with respect to the deployed tailgate **534**. The deployed utility surface **514** is also positioned above a wheel arch **509** of the vehicle **500** and/or quarter panel **506**. Accordingly, the horizontally extending utility surface **514** is positioned vertically at a height above the ground that facilitates use as a table or other work surface by a user (not shown), e.g., such that a user need not bend or squat over the deployed utility surface **514**.

[0040] The utility panel **512** shown in FIG. 5B is selectively removable from the vehicle **500**, e.g., by disassembling the legs **540** and removal of the panel tab **538** from the slot **536**. Upon removal, the utility panel(s) **512** may be stowed, e.g., within the cargo bed **504** of the vehicle **500**. Accordingly, the utility surface **514** of each utility panel(s) **512** may be at least partially concealed within the vehicle **500** and does not disrupt exterior surface **508** of the vehicle **500**.

[0041] The vehicle **500** also includes additional utility panels **512'** positioned on either side of the utility panel **512**. The utility panels **512'**, in contrast to the removable utility panel **512**, may generally pivot between a stowed position (not shown in FIGS. 5A or 5B) and a deployed position. Each of the utility panels **512'** may fold down or pivot from pivot points **532** with respect to the quarter panel **506** about axes and J-J, respectively. In the first or stowed position, exterior surfaces (not shown in FIGS. 5A or 5B) of the utility panels **512'** are generally integrated into the exterior surface **508** of the quarter panel, as with other example utility panels

described herein. In the deployed position illustrated in FIGS. 5A and 5B, a utility surface **514'** of each of the utility panels **512'** extends horizontally, similar to the utility surface **514** of the utility panel **512**. The utility surfaces **514'** are generally lower vertically than the utility surface **514** of the deployed utility panel **512**, facilitating use of the utility surfaces **514'** as a chair or seat next to utility surface **514**, which may be utilized as a table. Alternatively or in addition, pivoting the utility panels **512'** to their deployed/horizontal position may reveal a respective access port to the cargo bed **504**, or a storage area within the quarter panel **506**.

[0042] The vehicle **500** may also include a cover panel **542** that is configured to selectively conceal the slot **536**, e.g., when the utility panel **512** is not in use or is stowed on the vehicle **500**. In the illustrated example, the cover panel **542** may cooperate with the utility panel **512'** when each are in the stowed position to conceal the slot **536**, and generally provide a continuous exterior surface **508** of the vehicle **500**, e.g., in similar fashion as illustrated in connection with the exterior surfaces **208**, **308** of the vehicles **200**, **300** shown in FIGS. 2A and 3A. The cover panel **542** is pivotally supported on the quarter panel **506**, such that the cover panel **542** is selectively raised to expose the slot **536** to allow the utility panel **512** to be secured to the quarter panel **506**. Lighting may also be provided in the area of the quarter panel **506** via the cover panel **542**. More specifically, a light **544** may be positioned to cast light downward onto the utility panels **512'** and/or utility panel **512**, as illustrated in FIGS. 5A and 5B, respectively. Accordingly, the cover panel **542** is movable with respect to the quarter panel **506** between stowed/deployed positions such that, when deployed as shown in FIG. 5A and 5B, an interior or interior surface of the cover panel **542** extends outwardly from the vehicle outer surface **508** and faces downwardly, such that the light **544** casts light in a downward direction, e.g., onto utility surface **514** and/or utility surfaces **514'**. The cover panel **542** may have an exterior surface **546** that is integrated into the vehicle outer surface **508** when closed to conceal or cover the slot **536**.

[0043] The foregoing description includes exemplary embodiments in accordance with the present disclosure. These examples are provided for purposes of illustration only, and not for purposes of limitation. It will be understood that the present disclosure may be implemented in forms different from those explicitly described and depicted herein and that various modifications, optimizations, and variations may be implemented by a person of ordinary skill in the present art, consistent with the following claims.

What is claimed is:

1. A vehicle exterior panel, comprising:
 - a rigid body defining at least in part a vehicle outer surface;
 - a utility panel having an exterior surface and a generally planar utility surface, wherein the utility panel is movable with respect to the rigid body between a first position and a second position;
 - wherein the exterior surface of the utility panel is integrated into the vehicle outer surface and the utility surface of the utility panel is concealed at least partially within the vehicle outer surface when the utility panel is in the first position; and
 - wherein the utility surface is deployed outwardly from the vehicle outer surface and positioned substantially horizontally when the utility panel is moved to the second

position, the utility panel extending from a support point of the rigid body such that the utility surface provides a work surface extending from the vehicle.

2. The vehicle exterior panel of claim 1, wherein the utility panel is pivotable between the first and second positions.

3. The vehicle exterior panel of claim 1, wherein the utility panel is separable from the rigid body, and wherein the utility panel is moved from the first position to the second position by separating the utility panel from the rigid body.

4. The vehicle exterior panel of claim 3, wherein the utility panel is stowable within a cargo area of a truck bed.

5. The vehicle exterior panel of claim 1 further comprising an accessory storage cavity, wherein the accessory storage cavity is concealed by the utility panel when the utility panel is in the first position.

6. The vehicle exterior panel of claim 1, wherein the vehicle exterior panel is a rear quarter panel of a vehicle.

7. The vehicle exterior panel of claim 1 further comprising a cover panel having an exterior surface and an interior surface; wherein the cover panel is movable with respect to the rigid body between a first position and a second position; wherein the exterior surface of the cover panel is integrated into the vehicle outer surface and the interior surface of the cover panel is concealed at least partially within the vehicle outer surface when the cover panel is in the first position; wherein the interior surface is deployed outwardly from the vehicle outer surface and positioned facing a downward direction when the cover panel is moved to the second position, the cover panel supported at a position above the support point; and wherein the interior surface of the cover panel includes a lighting unit configured to cast light in a downward direction.

8. The vehicle exterior panel of claim 1, wherein the utility panel is a first utility panel, and wherein the vehicle exterior panel comprises at least a second utility panel, the second utility panel movable with respect to the rigid body between stowed and deployed positions, the second utility panel defining a second utility surface that is deployed outwardly from the vehicle outer surface and substantially horizontally when the second utility panel is moved to the second position; wherein the second utility panel is supported at a vertical position below the support point of the first utility panel.

9. The vehicle exterior panel of claim 8, wherein the second utility panel is configured to support a user sitting upon the second utility surface when the second utility panel is in the second position.

10. The vehicle exterior panel of claim 9, further comprising a third utility panel movable with respect to the rigid body between a first position and a second position, the third utility panel defining a third utility surface that is deployed outwardly from the vehicle outer surface and substantially horizontally when the third utility panel is moved to the second position, the third utility panel supported at the vehicle outer surface at a vertical position below the support point of the first utility panel; wherein the third utility panels is configured to support a user sitting upon the third utility surface at a substantially same height with as the second utility surface of the second utility panel; wherein the second and third utility panels are positioned on opposite sides of the first utility panel.

11. A vehicle, comprising:

a vehicle exterior panel having a rigid body defining at least in part a vehicle outer surface; and

a utility panel having an exterior surface and a generally planar utility surface, wherein the utility panel is movable with respect to the rigid body between a first position and a second position;

wherein the exterior surface of the utility panel is integrated into the vehicle outer surface and the utility surface of the utility panel is concealed at least partially within the vehicle outer surface when the utility panel is in the first position; and

wherein the utility surface is deployed outwardly from the vehicle outer surface and positioned substantially horizontally when the utility panel is moved to the second position, the utility panel extending from a support point of the rigid body such that the utility surface provides a work surface extending from the vehicle.

12. The vehicle of claim 11, wherein the utility panel is pivotable between the first and second positions.

13. The vehicle of claim 11, wherein the utility panel is separable from the rigid body, and wherein the utility panel is moved from the first position to the second position by separating the utility panel from the rigid body.

14. The vehicle of claim 13, further comprising a truck bed cargo area, wherein the utility panel is stowable within the truck bed cargo area.

15. The vehicle of claim 11, wherein the vehicle exterior panel is a rear quarter panel of the vehicle.

16. The vehicle of claim 15, further comprising a tailgate of the vehicle configured to be lowered to an open position facilitating access to a cargo bed of the vehicle, wherein the utility surface is vertically above a deployed surface of the tailgate when the utility panel is in the second position and the tailgate is opened.

17. The vehicle of claim 11, wherein the vehicle exterior panel is a side panel of the vehicle.

18. The vehicle of claim 11, wherein the utility panel is a first utility panel, and wherein the vehicle exterior panel comprises at least a second utility panel, the second utility panel movable with respect to the rigid body between stowed and deployed positions, the second utility panel defining a second utility surface that is deployed outwardly from the vehicle outer surface and substantially horizontally when the second utility panel is moved to the second position; wherein the second utility panel is supported at a vertical position below the support point of the first utility panel.

19. The vehicle of claim 18, wherein the second utility panel is configured to support a user sitting upon the second utility surface when the second utility panel is in the second position.

20. The vehicle of claim 18, further comprising a third utility panel movable with respect to the rigid body between a first position and a second position, the third utility panel defining a third utility surface that is deployed outwardly from the vehicle outer surface and substantially horizontally when the third utility panel is moved to the second position, the third utility panel supported at the vehicle outer surface at a vertical position below the support point of the first utility panel; wherein the third utility panels is configured to support a user sitting upon the third utility surface at a substantially same height with as the second utility surface

of the second utility panel; wherein the second and third utility panels are positioned on opposite sides of the first utility panel.

* * * * *