



US00D804996S

(12) **United States Design Patent**
Sahara et al.

(10) **Patent No.:** **US D804,996 S**

(45) **Date of Patent:** **** Dec. 12, 2017**

(54) **AUTOMOBILE**

(71) Applicant: **HONDA MOTOR CO., LTD.**, Tokyo (JP)

(72) Inventors: **Ken Sahara**, Wako (JP); **Hirotoishi Tamura**, Wako (JP)

(73) Assignee: **HONDA MOTOR CO., LTD.**, Tokyo (JP)

(**) Term: **15 Years**

(21) Appl. No.: **29/561,943**

(22) Filed: **Apr. 21, 2016**

(30) **Foreign Application Priority Data**

Oct. 23, 2015 (JP) 2015-023584

(51) **LOC (10) Cl.** **12-08**

(52) **U.S. Cl.**
USPC **D12/91**

(58) **Field of Classification Search**

USPC D12/86, 90-92, 88; D21/421, 433, 434;
296/181.1, 181.5
CPC B62D 35/00; B62D 25/00; B62D 25/06;
B62D 33/00

See application file for complete search history.

(56) **References Cited**

U.S. PATENT DOCUMENTS

D686,949 S * 7/2013 Minami D12/91
D699,157 S * 2/2014 Bischoff D12/92

D705,701 S * 5/2014 Hildebrand D12/91
D714,686 S * 10/2014 Bischoff D12/91
D719,875 S * 12/2014 Jang D12/91
D725,550 S * 3/2015 Wolff D12/91
D759,540 S * 6/2016 Davidson D12/91
D761,693 S * 7/2016 Lian D12/91
D766,778 S * 9/2016 Lian D12/91

* cited by examiner

Primary Examiner — Melody N Brown

(74) *Attorney, Agent, or Firm* — Westerman, Hattori, Daniels & Adrian, LLP

(57) **CLAIM**

The ornamental design for an automobile, as shown and described.

DESCRIPTION

FIG. 1 is a front and left side perspective view of an automobile showing our new design; FIG. 2 is a rear and right side perspective view thereof; FIG. 3 is a left side elevational view thereof; FIG. 4 is a right side elevational view thereof; FIG. 5 is a top plan view thereof; FIG. 6 is a front elevational view thereof; and, FIG. 7 is a rear elevational view thereof.

The broken lines in the drawings illustrate portions of the automobile that forms no part of the claimed design.

1 Claim, 7 Drawing Sheets

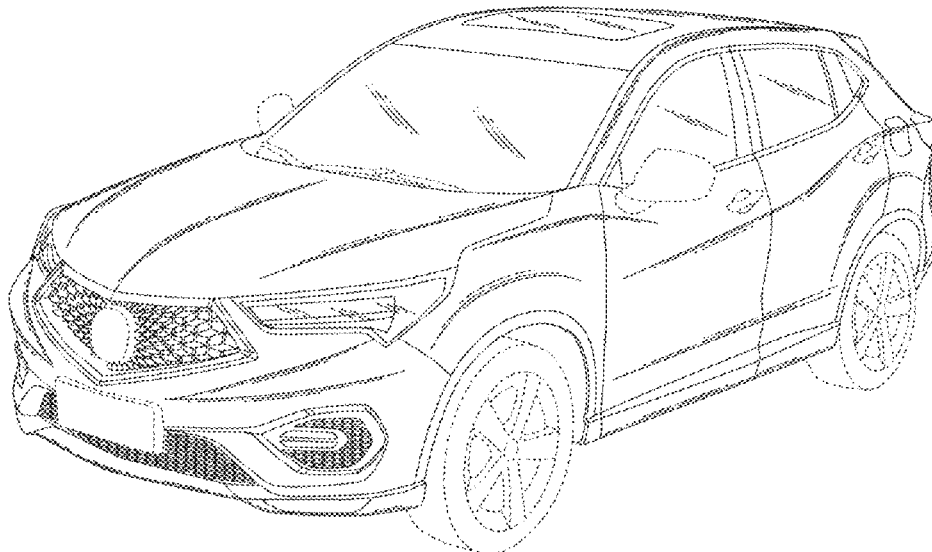

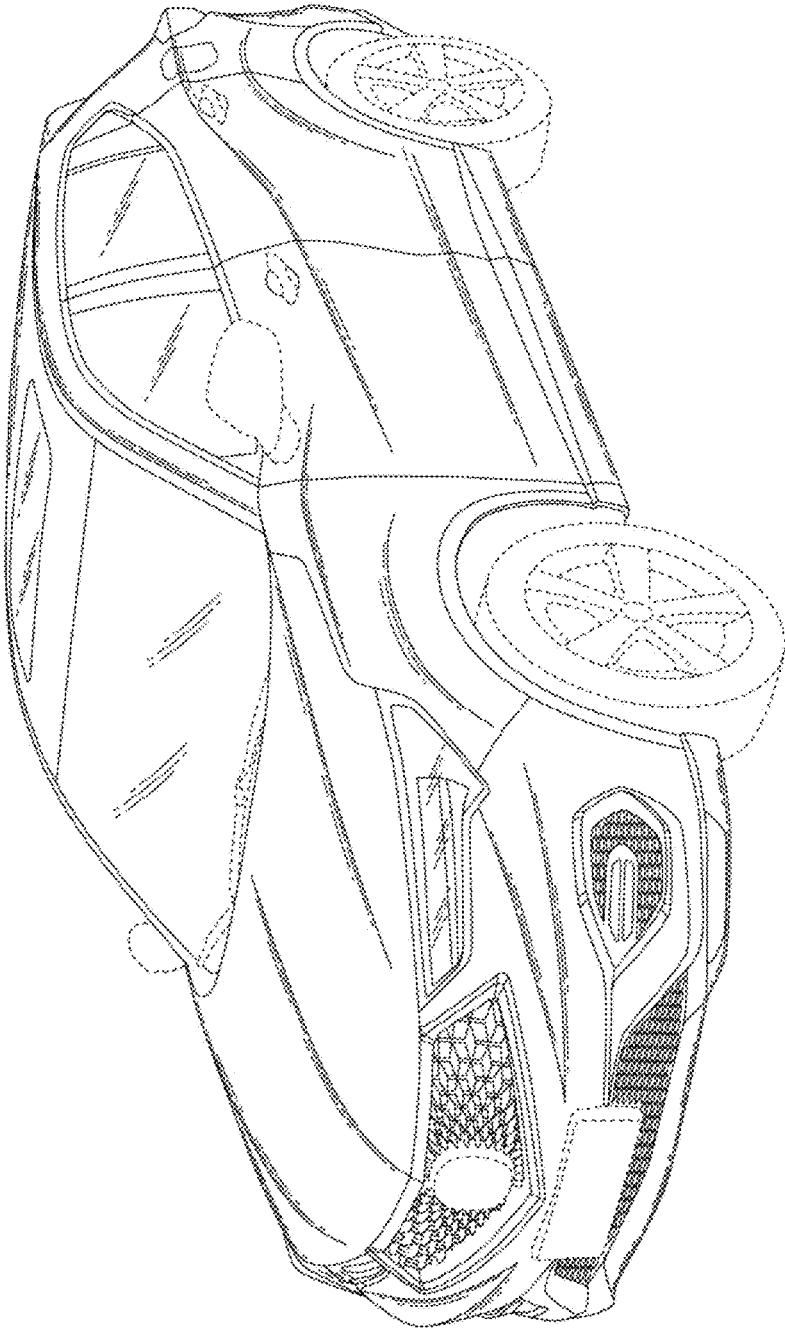

FIG.1

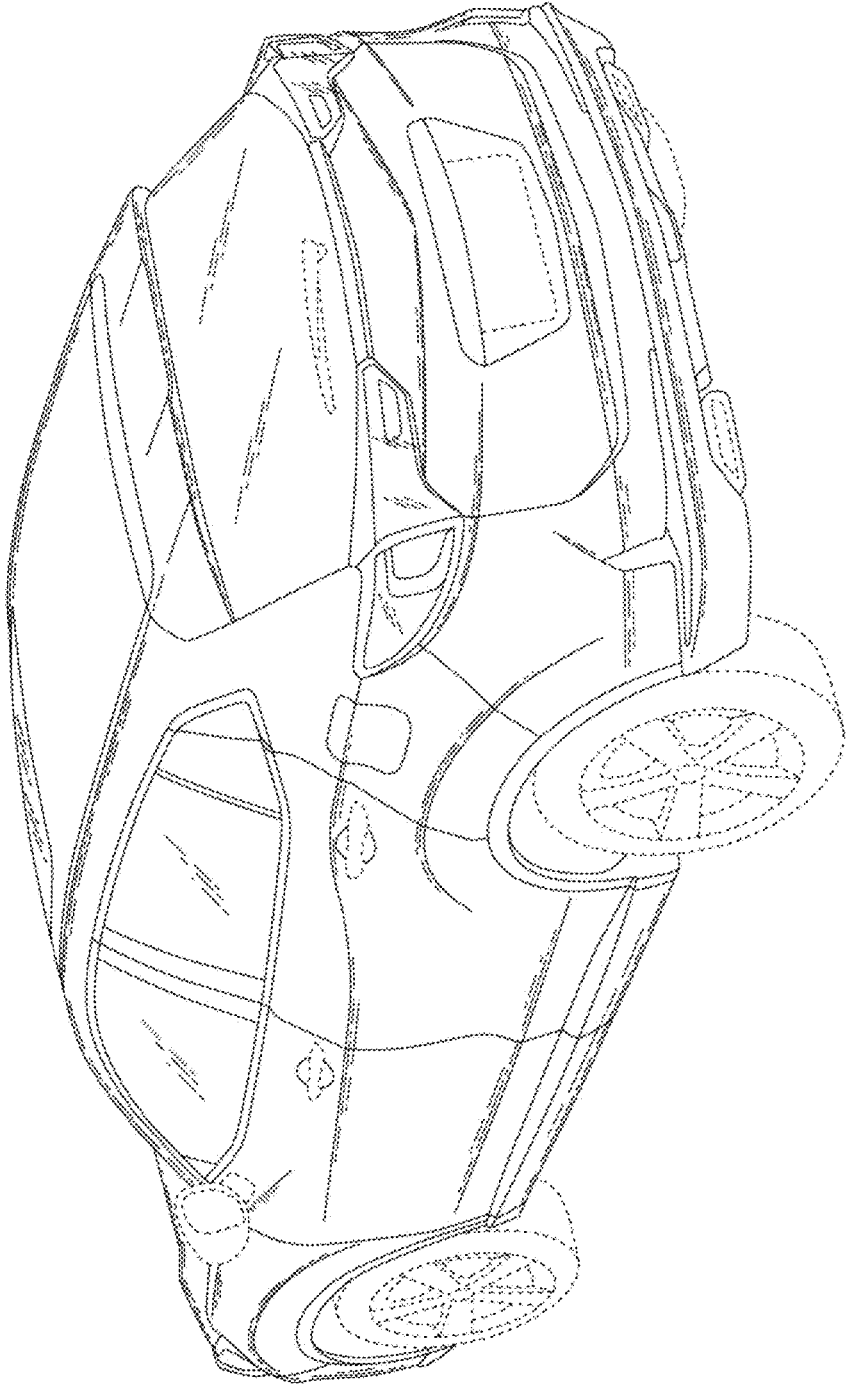

FIG.2

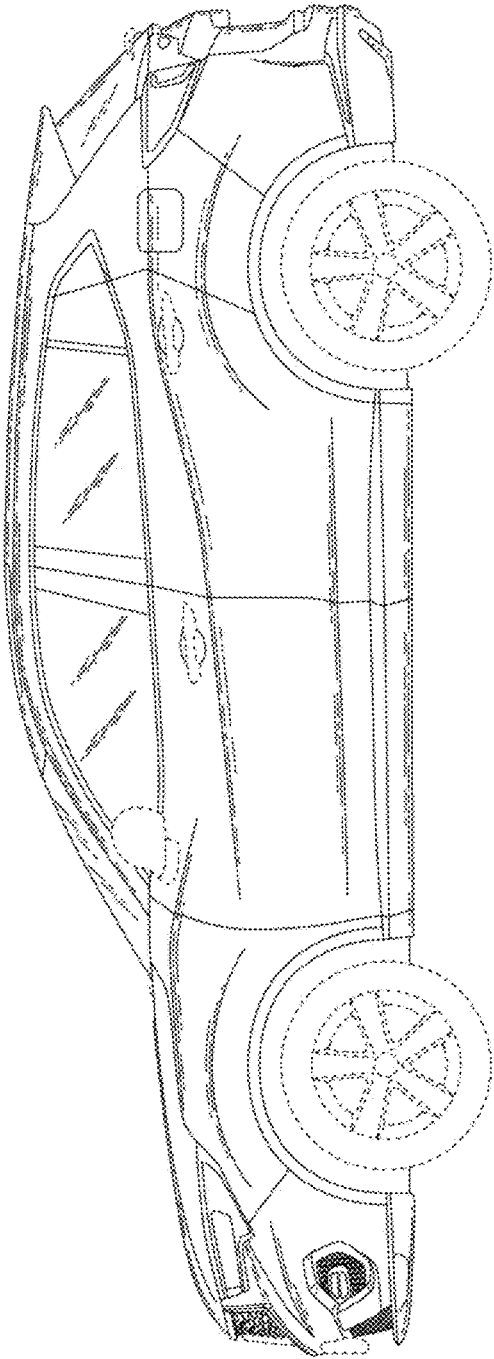

FIG.3

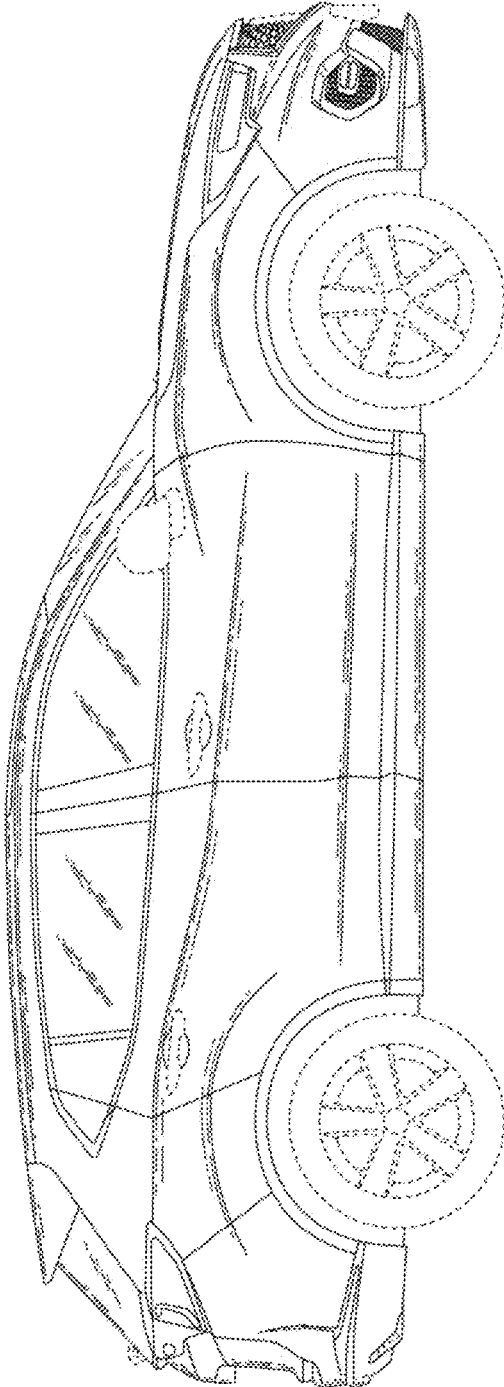

FIG.4

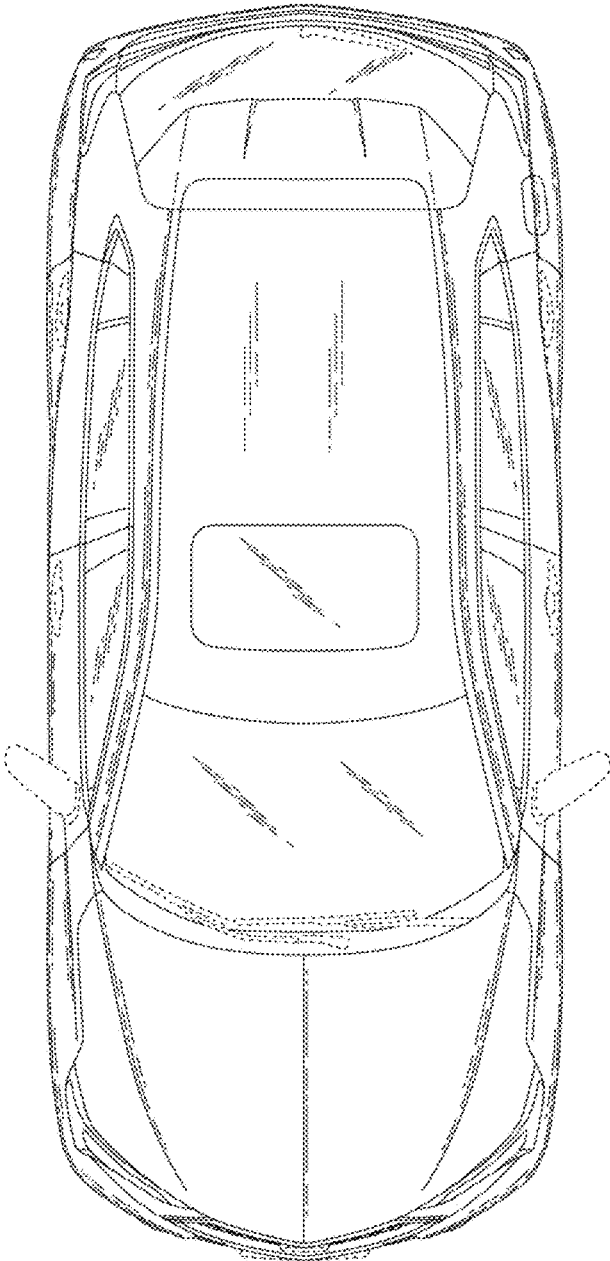

FIG.5

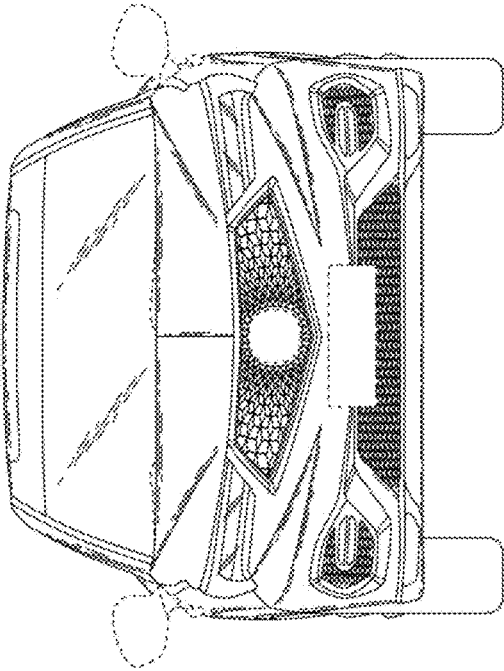

FIG.6

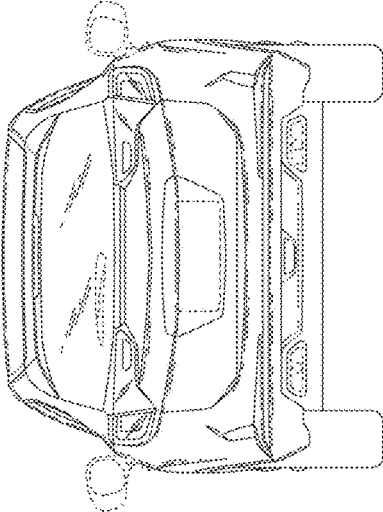

FIG.7