

US011727736B2

(12) **United States Patent**
Huggins et al.

(10) **Patent No.:** **US 11,727,736 B2**
(45) **Date of Patent:** ***Aug. 15, 2023**

(54) **USING A VEHICLE TO IDENTIFY A STATUS OF A GARAGE DOOR**

(71) Applicant: **Ford Global Technologies, LLC**,
Dearborn, MI (US)

(72) Inventors: **Scott Huggins**, Novi, MI (US); **Jeremy Lerner**, Southfield, MI (US); **Jason Woo**, Northville, MI (US); **Daniel Sullivan**, Grosse Pointe, MI (US); **Paige Wong**, Ann Arbor, MI (US)

(73) Assignee: **Ford Global Technologies, LLC**,
Dearborn, MI (US)

(*) Notice: Subject to any disclaimer, the term of this patent is extended or adjusted under 35 U.S.C. 154(b) by 0 days.

This patent is subject to a terminal disclaimer.

(21) Appl. No.: **17/341,028**

(22) Filed: **Jun. 7, 2021**

(65) **Prior Publication Data**

US 2022/0001886 A1 Jan. 6, 2022

Related U.S. Application Data

(63) Continuation of application No. 16/921,692, filed on Jul. 6, 2020, now Pat. No. 11,120,655.

(51) **Int. Cl.**

G07C 9/00 (2020.01)

B60W 50/14 (2020.01)

(Continued)

(52) **U.S. Cl.**

CPC **G07C 9/00896** (2013.01); **B60W 50/14** (2013.01); **G07C 9/00** (2013.01);

(Continued)

(58) **Field of Classification Search**

CPC .. G07C 9/00; G07C 9/00896; G07C 9/00928; G05B 19/00; B60W 30/00; B60W 30/06

See application file for complete search history.

(56) **References Cited**

U.S. PATENT DOCUMENTS

9,879,466 B1 * 1/2018 Yu G07C 9/29
10,846,960 B1 * 11/2020 Lemberger H04N 7/183

(Continued)

OTHER PUBLICATIONS

NPL Search (Jul. 13, 2022).*

Primary Examiner — Van T Trieu

(74) *Attorney, Agent, or Firm* — Brandon Hicks; Eversheds Sutherland (US) LLP

(57) **ABSTRACT**

Example embodiments described in this disclosure are generally directed to using a vehicle to identify a status of a garage door, such as, for identifying whether the garage door is fully closed, fully open, or partially open. The identification may be carried out in response to an inquiry from an individual, such as, a driver of the vehicle that has exited through the garage door. A detection apparatus such as an image capture system or an ultrasonic sensor that can be a part of a vehicle security system may be used for identifying the status of the garage door. The image capture system may capture and store an image of the garage door when the vehicle is exiting the garage. Upon receiving an inquiry from the driver, the garage door status detection system may display the image on a smartphone of the driver or an infotainment system in the vehicle.

19 Claims, 5 Drawing Sheets

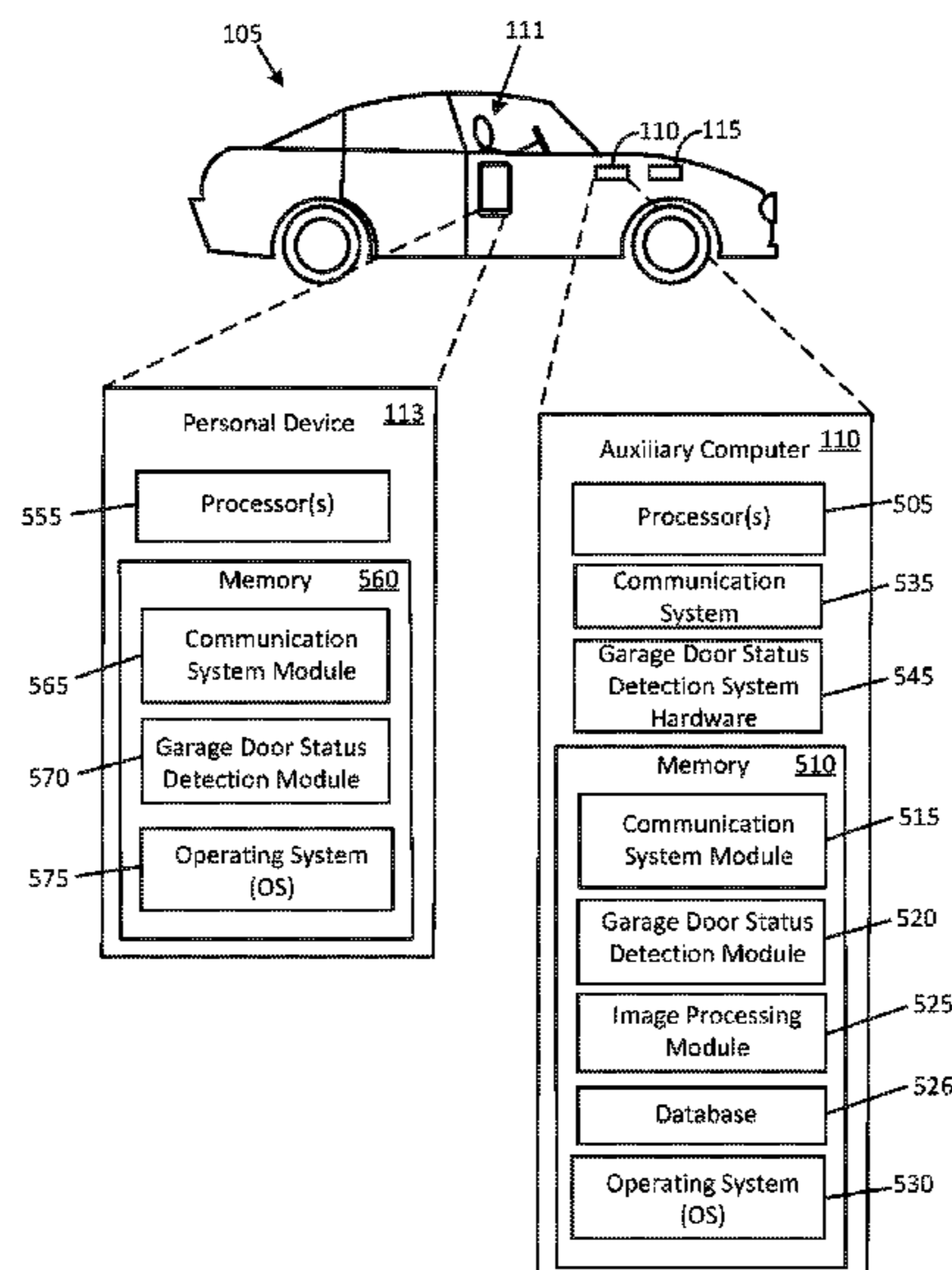

- (51) **Int. Cl.**
H04W 4/021 (2018.01)
B60R 1/00 (2022.01)
G06V 20/58 (2022.01)

- (52) **U.S. Cl.**
CPC *H04W 4/021* (2013.01); *B60R 1/00*
(2013.01); *B60R 2300/8093* (2013.01); *B60W*
2050/146 (2013.01); *B60W 2420/42* (2013.01);
B60W 2420/54 (2013.01); *G06V 20/58*
(2022.01)

(56) **References Cited**

U.S. PATENT DOCUMENTS

11,120,655	B1 *	9/2021	Huggins	G07C 9/00
2015/0084779	A1 *	3/2015	Saladin	E05F 15/77
					340/686.6
2018/0004747	A1 *	1/2018	Smith	H04N 7/185
2019/0048639	A1 *	2/2019	Lickfelt	G01S 19/51
2019/0063140	A1 *	2/2019	Trundle	G06V 20/62
2020/0269688	A1 *	8/2020	Dagley	H04L 67/12

* cited by examiner

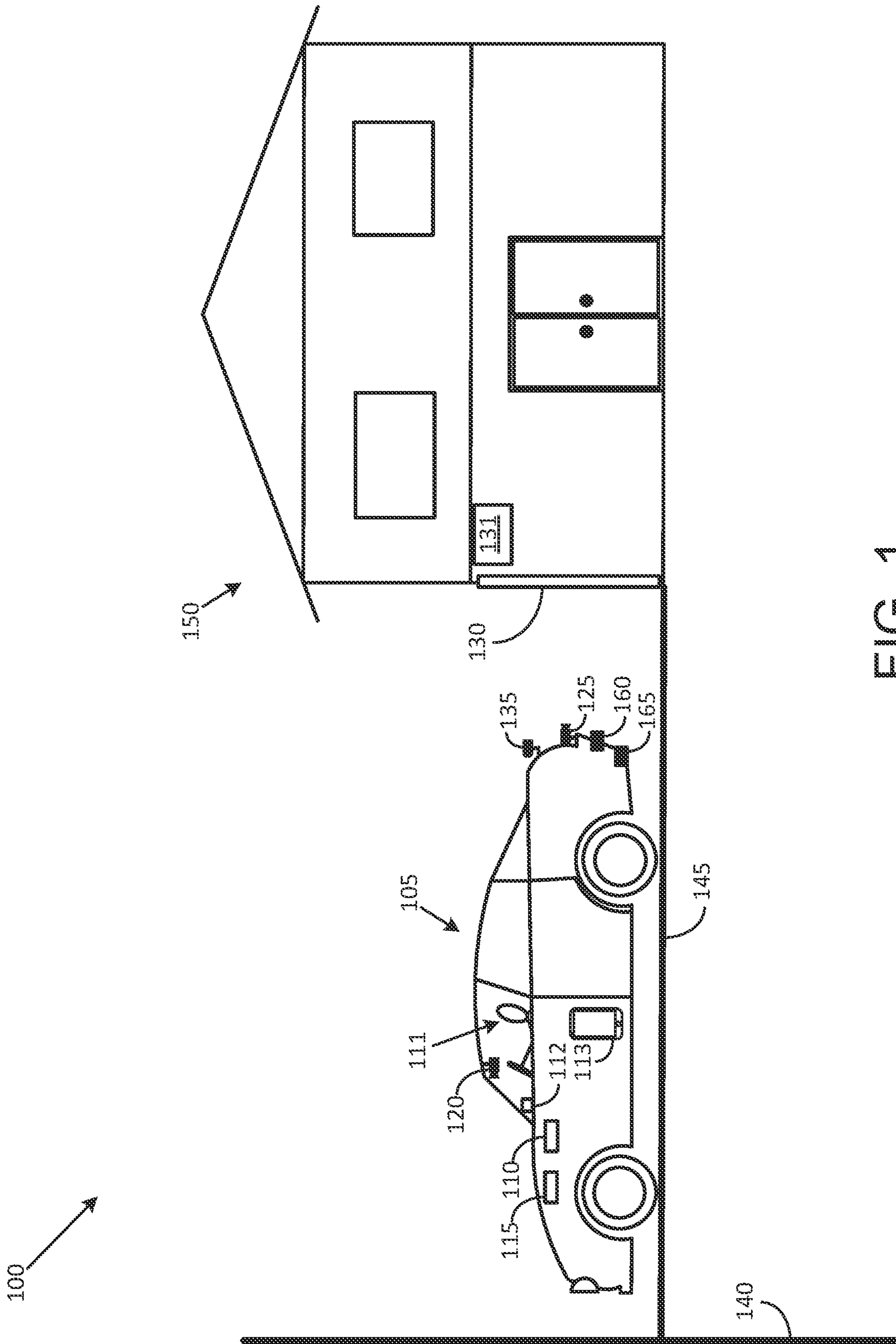

FIG. 1

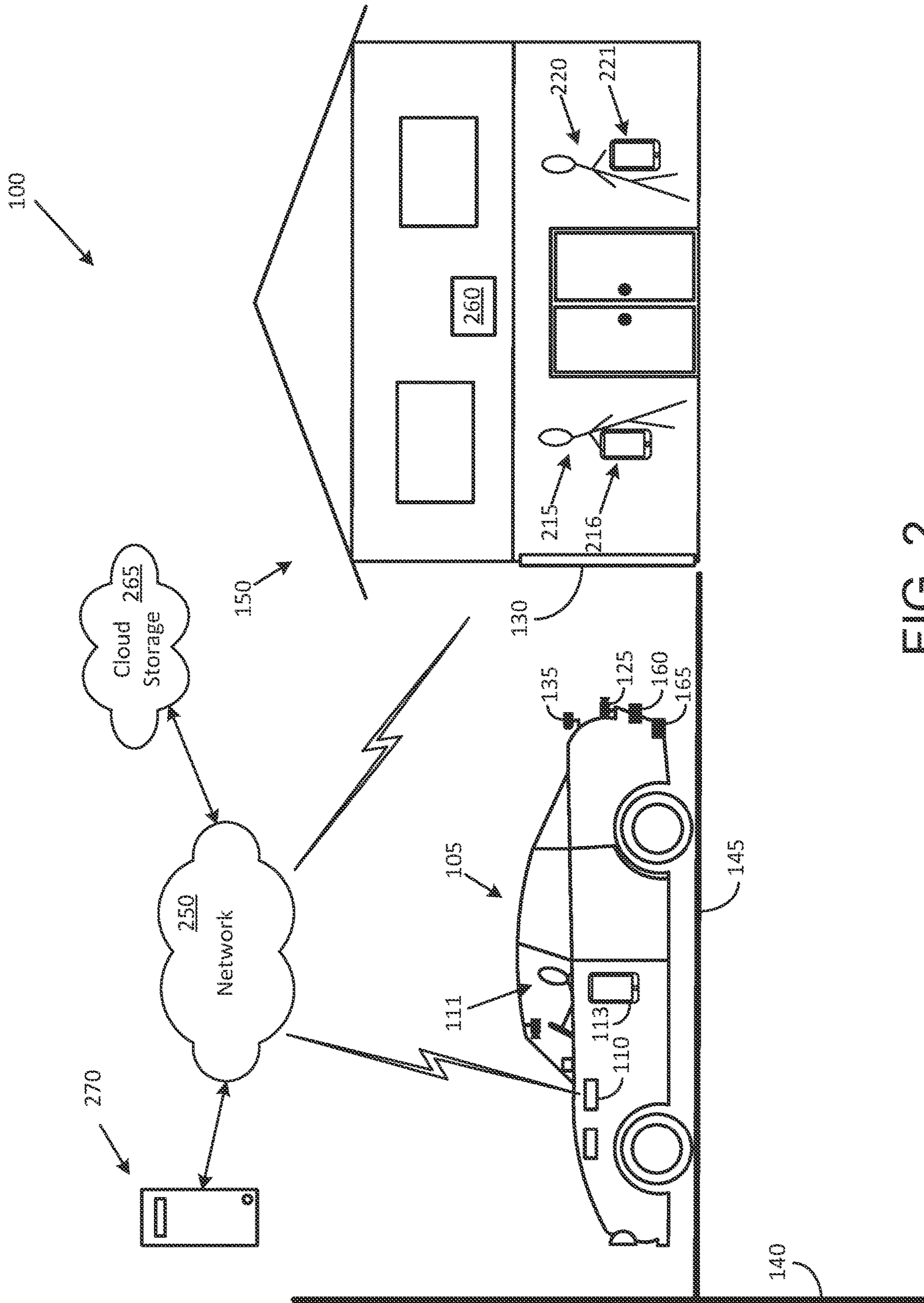

FIG. 2

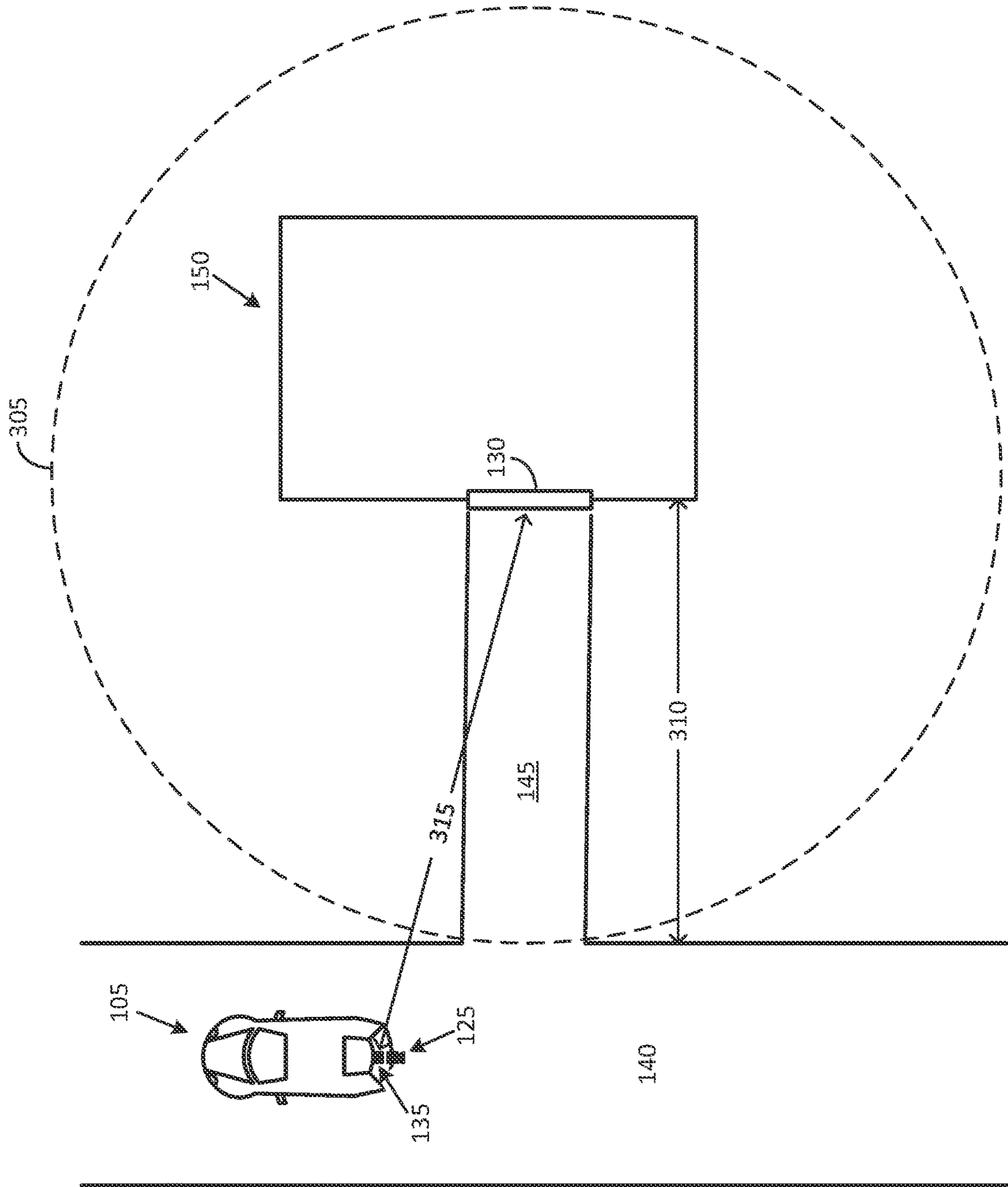

FIG. 3

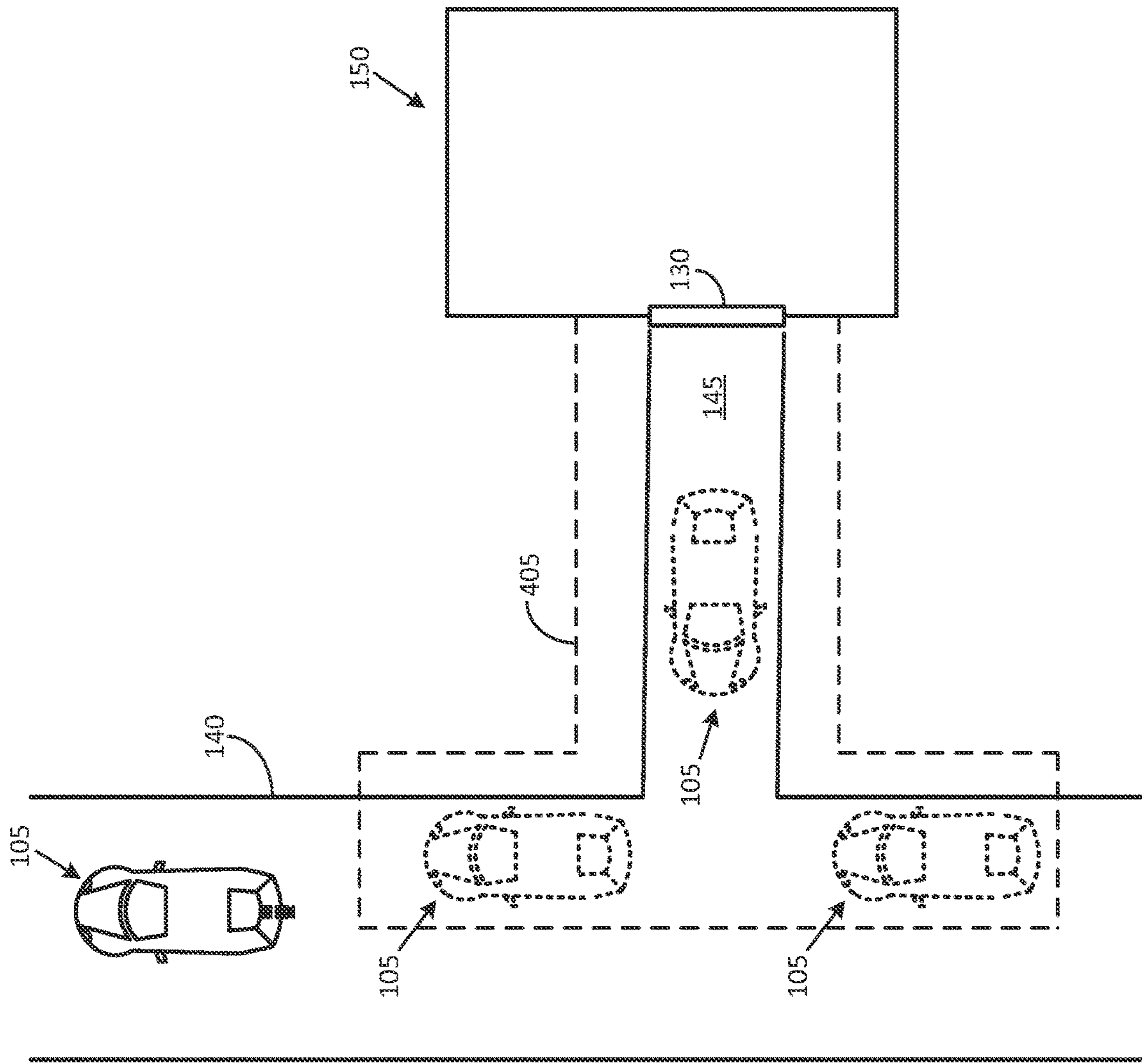

FIG. 4

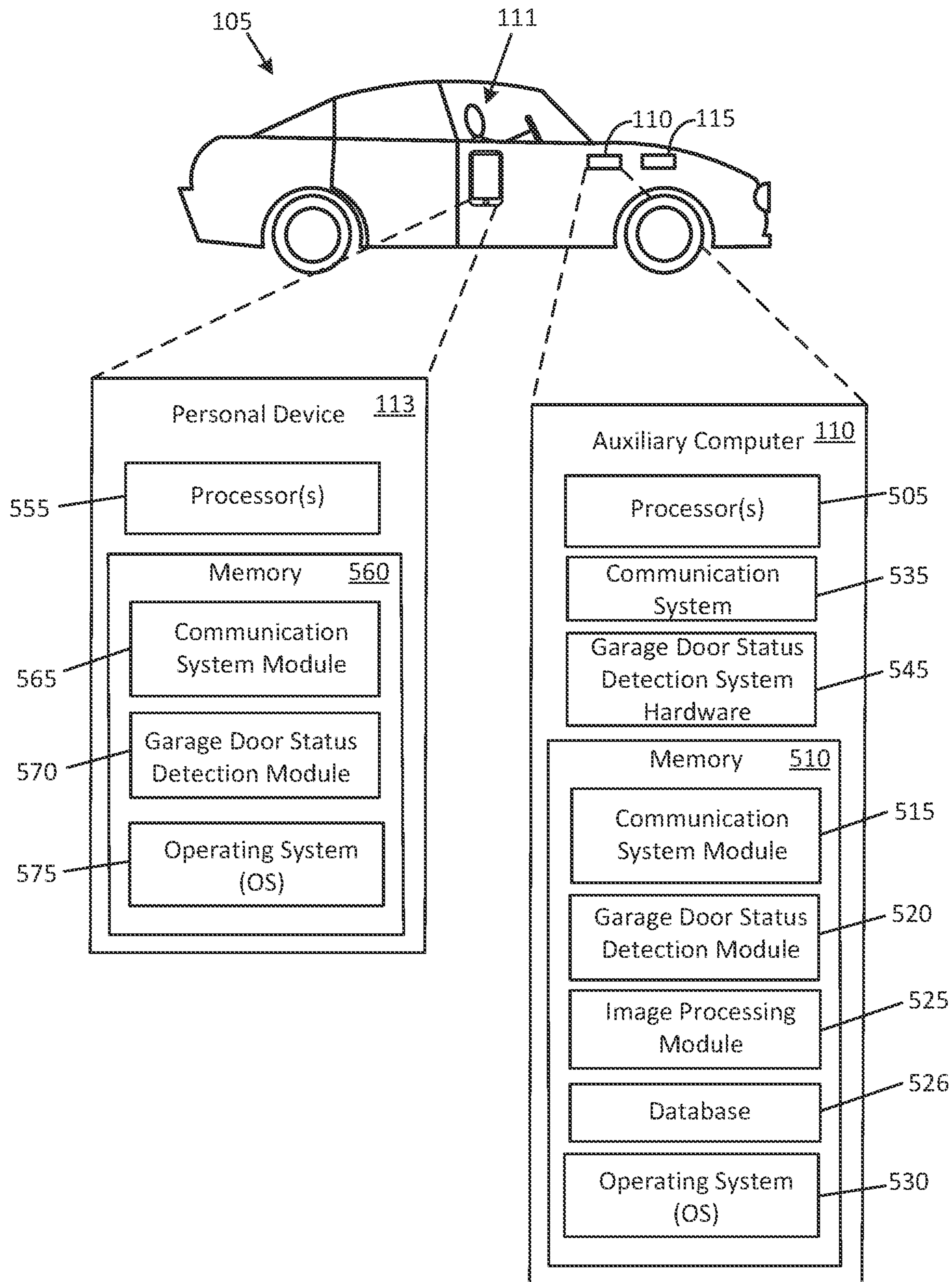

FIG. 5

1

USING A VEHICLE TO IDENTIFY A STATUS OF A GARAGE DOOR

CROSS-REFERENCE TO RELATED APPLICATIONS

The present application claims priority to, the benefit of, and is a continuation application of U.S. application Ser. No. 16/921,692, filed Jul. 6, 2020, (since issued as U.S. Pat. No. 11,120,655 on Sep. 14, 2021) which is hereby incorporated by reference herein in its entirety.

BACKGROUND

A driver pulling a vehicle out of a garage is often preoccupied with various thoughts, such as, for example, work-related activities when driving out to work, time-related activities when dropping off a child at school, or a list of items to be purchased at a grocery store. In some cases, when not preoccupied with such thoughts, the driver may be distracted due to performing actions such as handling children in the vehicle, talking to a passenger in the vehicle, or looking out for vehicles passing by on a road at the end of a driveway to the garage. Typically, and in spite of being preoccupied or distracted, the driver may automatically depress a garage door remote control button in the vehicle in order to close a garage door of the garage as the vehicle is exiting the garage. The action of depressing the garage door remote control button may be carried out automatically without paying conscious attention to the action.

After driving away from the building, and out of sight of the garage, the driver may suddenly wonder if he/she had actually depressed the garage door remote control button and if the garage door had actually closed in response to depressing the garage door remote control button. In some cases, the garage door may have been left open because the driver had forgotten to depress the garage door remote control button. In other cases, the driver may have depressed the garage door remote control button and the garage door may have begun to close. However, the garage door may then have rolled back open when an infrared sensor detected an object in the movement path of the garage door.

The driver may therefore decide either to turn the vehicle around and go back to verify whether the garage door is closed or may decide to phone a person residing in the building to verify whether the garage door is closed. Such actions can be time-consuming and frustrating to carry out. Accordingly, a need exists to provide a solution that would allow the driver to identify a status of the garage door (open, close, partially open, for example) without having to go back to the garage or to call the person residing in the building.

BRIEF DESCRIPTION OF THE DRAWINGS

A detailed description is set forth below with reference to the accompanying drawings. The use of the same reference numerals may indicate similar or identical items. Various embodiments may utilize elements and/or components other than those illustrated in the drawings, and some elements and/or components may not be present in various embodiments. Elements and/or components in the figures are not necessarily drawn to scale. Throughout this disclosure, depending on the context, singular and plural terminology may be used interchangeably.

FIG. 1 shows an example of a garage door status detection system in accordance with an embodiment of the disclosure.

2

FIG. 2 illustrates a first example scenario associated with operating a garage door status detection system in accordance with the disclosure.

FIG. 3 illustrates an example geofence that may be used as a part of a garage door status detection system in accordance with the disclosure.

FIG. 4 illustrates another example geofence that may be used as a part of a garage door status detection system in accordance with the disclosure.

FIG. 5 shows some example components that can be included in a garage door status detection system in accordance with the disclosure.

DETAILED DESCRIPTION

Overview

In terms of a general overview, certain embodiments described in this disclosure are directed to systems and methods for using a vehicle to identify a status of a garage door, such as, for example, identifying whether the garage door is fully closed, fully open, or partially open. The identification may be carried out in response to an inquiry received from an individual, such as, for example, a driver of a vehicle that has exited through the garage door. In an example implementation, a detection apparatus, such as an image capture system or an ultrasonic sensor, that can be a part of a vehicle security system provided in the vehicle and may be used for identifying the status of the garage door. The image capture system may capture and store an image (or a video clip) of the garage door when the vehicle is exiting the garage. Upon receiving an inquiry from the driver, the garage door status detection system may display the image (or video clip) on a smartphone of the driver or on an infotainment system in the vehicle. In some cases, a text message may be displayed indicating the status of the garage door (open, closed, partially-open, etc.)

Illustrative Embodiments

The disclosure will be described more fully hereinafter with reference to the accompanying drawings, in which example embodiments of the disclosure are shown. This disclosure may, however, be embodied in many different forms and should not be construed as limited to the example embodiments set forth herein. It will be apparent to persons skilled in the relevant art that various changes in form and detail can be made to various embodiments without departing from the spirit and scope of the present disclosure. Thus, the breadth and scope of the present disclosure should not be limited by any of the above-described example embodiments but should be defined only in accordance with the following claims and their equivalents. The description below has been presented for the purposes of illustration and is not intended to be exhaustive or to be limited to the precise form disclosed. It should be understood that alternate implementations may be used in any combination desired to form additional hybrid implementations of the present disclosure. For example, any of the functionality described with respect to a particular device or component may be performed by another device or component. Furthermore, while specific device characteristics have been described, embodiments of the disclosure may relate to numerous other device characteristics. Further, although embodiments have been described in language specific to structural features and/or methodological acts, it is to be understood that the disclosure is not necessarily limited to the specific features or acts

described. Rather, the specific features and acts are disclosed as illustrative forms of implementing the embodiments.

Certain words and phrases are used herein solely for convenience and such words and terms should be interpreted as referring to various objects and actions that are generally understood in various forms and equivalencies by persons of ordinary skill in the art. For example, the word “building” as used herein refers to any of various structures such as, for example, a house, a home, an office, or a commercial establishment (a store, a manufacturing facility, a warehouse, etc.). The word “vehicle” as used herein encompasses various types of vehicles such as cars, trucks, vans, and sports utility vehicles (SUVs), and also encompasses various types of automobiles such as a boat, a tractor, or a recreational vehicle (RV) that may house an anti-theft system. Words such as “wireless” or “wirelessly” as used herein are not intended to preclude other forms of communication such as optical communications and wired communications. The examples provided herein encompass such alternative communication technologies. Furthermore, it should be understood that the word “example” as used herein is intended to be non-exclusionary and non-limiting in nature.

FIG. 1 shows an example of a garage door status detection system 100 in accordance with an embodiment of the disclosure. The garage door status detection system 100 includes a vehicle 105 that may be any of various types of vehicles that include components such as a vehicle systems controller 115, an infotainment system 112, an auxiliary computer 110, and various sensors and detection devices that are communicatively coupled to the auxiliary computer 110, and/or the vehicle systems controller 115. In an example implementation, the sensors and detection devices may be included in any of a vehicle security system used to protect the vehicle 105 from vandalism and other untoward activities, a vehicle driver assist system used to help the driver operate the vehicle, and/or an autonomous or semi-autonomous vehicle operation system that allows the vehicle 105 to operate autonomously or with minimal driver input. In another example implementation, the sensors and detection devices may be installed in the vehicle 105 for performing various actions in accordance with the disclosure.

In the example scenario illustrated in FIG. 1, the vehicle 105 is typically parked in a garage of a building 150. The building 150 may be a residence, a house, an office, or a commercial establishment such as a store, a manufacturing facility, or a warehouse that is owned by an individual associated with the vehicle 105. The vehicle systems controller 115 that is a part of the vehicle 105 may perform various functions such as controlling engine operations (fuel injection, speed control, emissions control, braking, etc.), managing climate controls (air conditioning, heating etc.), activating airbags, and issuing warnings (check engine light, bulb failure, low tire pressure, vehicle in blind spot, etc.).

The auxiliary computer 110 may execute various functions associated with various devices in the vehicle 105, including devices used for protecting the vehicle 105 against theft, break-ins, or other malicious activities. Various sensors and detection devices, such as, for example, an image capture system 120, an image capture system 125, an ultrasonic sensor 135, a radar sensor 160, and/or a light detection and ranging (LIDAR) device 165, may be installed at various locations in the vehicle 105. For example, the image capture system 120 can include a camera that is mounted above a dashboard of the vehicle 105 and is arranged to capture images of objects located in front of the vehicle 105. The image capture system 125 can include

another camera that is mounted on the bumper of the vehicle 105 and is arranged to capture images of objects located behind the vehicle 105.

The ultrasonic sensor 135 may be mounted on the bumper of the vehicle 105 or the trunk of the vehicle 105 and is arranged to detect objects located behind the vehicle 105 using ultrasonic signals. The ultrasonic signals may be used to detect a status of the garage door 130, by detecting a change in a distance measurement between a closed condition of the garage door 130 and an open condition of the garage door 130. The ultrasonic sensor 135 can be used day or night for detection purposes and may be coupled to the image capture system 125 for capturing images of the garage door 130 when the ultrasonic sensor detects a change in status of the garage door 130 (for example, when the garage door 130 is closing).

In one example scenario, the ultrasonic sensor 135 may detect the garage door 130 closing, when the driver 111 depresses a button of a garage door remote control device in the vehicle 105 and the vehicle 105 begins to move out on to the driveway 145. The image capture system 125 may activate to capture an image (or a video clip) of the garage door 130 when the ultrasonic sensor 135 sends a signal indicating the closing of the garage door 130. In this example scenario, the vehicle 105 is being driven forwards by the driver 111 on the driveway 145 and out of the garage.

In another example scenario, the vehicle 105 may be reversed out of the garage with a front portion of the vehicle 105 facing the garage door 130. In this scenario, the image capture system 120 may receive a wireless signal from a radio transmitter 131 that is coupled to a garage door opening motor mechanism. The wireless signal may be transmitted to the image capture system 120 by the radio transmitter 131 each time the garage door opening motor mechanism is operated. Upon receiving the wireless signal, the image capture system 120 may start recording a video clip that includes images of the garage door 130 in action (closing or opening). The video clip may be stored in a storage device (not shown) that can be a part of the garage door status detection system 100. The vehicle 105 may be driven out of the driveway 145 and on to a road 140. The vehicle 105 may then reach a location on the road 140 where the garage door 130 is no longer visible to the driver 111.

At this time, the driver 111 may be struck with a thought that he/she may not have closed the garage door 130. Rather than turn around towards the building 150 to check, or call someone in the building to verify whether the garage door 130 is closed, the driver may, in accordance with disclosure, transmit an inquiry to the garage door status detection system 100. The inquiry may be transmitted, for example, to the auxiliary computer 110, in various ways, such as, for example, through a touch screen of the infotainment system 112, or via a personal device 113 of the driver 111. The personal device 113 can be, for example, a smartphone, a tablet computer, or a phablet (phone plus tablet). Upon receiving the inquiry, the auxiliary computer 110 may play the video clip upon the infotainment system 112 and/or the personal device 113 and the driver 111 may observe the video clip to determine the status of the garage door 130. In some cases, the auxiliary computer 110 may automatically display an image or a text message upon the infotainment system 112 and/or the personal device 113 to indicate a status of the garage door 130, when the vehicle 105 travels beyond a certain distance from the building 150 (beyond a geofence around the building 150, for example).

FIG. 2 illustrates yet another example scenario associated with operating the garage door status detection system 100

in accordance with the disclosure. In this scenario, devices such as the image capture system **125** or the image capture system **120** may capture an image or a video clip of the garage door **130** in the manner described above when the vehicle **105** is driven out of the garage (either in forward gear or in reverse gear). The vehicle **105** may be driven out of the driveway **145** and on to the road **140** to a location where the garage door **130** is no longer visible to the driver **111**.

The auxiliary computer **110** automatically processes the images and/or the video clip captured by the image capture system **125** (or the image capture system **120**) when the vehicle **105** was on the driveway **145**, and determines that the driver **111** of the vehicle **105** has forgotten to close the garage door **130**. Upon making such a determination, the auxiliary computer **110** may wirelessly transmit an alert signal through a network **250** to a device **260** in the building **150**. The driver **111** may not be alerted about the transmission. The device **260** may be any of various types of devices, such as, for example, a smart home device. One example of a smart home device is Amazon's Alexa®. The smart home device may cooperate with a garage door operating system (not shown) for automatically closing the garage door **130**. The driver **111** may, or may not, be made aware of the closing operation.

In an alternative implementation, the auxiliary computer **110** may wirelessly transmit an alert signal through a network **250** to a personal device **216** of the individual **215** residing in the building **150** or to an alerting device (beeper, flashing light, etc.) located in the building **150**. Upon receiving the signal, the individual **215** may go to the garage and close the garage door **130**. In one embodiment, the driver **111** may be informed of the event as well, so as to remind the driver **111** to make note to close the garage door **130** in the future. This action may be carried out by transmitting a text message, an email message, and/or a voice message to the driver **111**. In another embodiment, the driver **111** may not be informed of the event so as to avoid distracting the driver **111** when driving.

In yet another alternative implementation, the auxiliary computer **110** may refer to a priority list to identify one or more of several recipients for transmitting an alert signal. The priority list may be stored in one or more of various devices such as, for example, in the auxiliary computer **110**, in cloud storage **265**, and/or in a server computer **270**. An example priority list may indicate that the driver **111** of the vehicle **105** has a highest priority, followed in sequence, by a spouse, a son/daughter, and a neighbor, for example. In one example case, an order of priorities of the various individuals in the priority list may be assigned by the driver **111** or an adult in a family residing in the building **150**.

In the illustration shown in FIG. 2, two individuals are present in the building **150** when the auxiliary computer **110** is scrutinizing a priority list to identify a recipient for transmitting an alert signal. The priority list in this example may not include the driver **111** and may indicate that the individual **220** has a higher priority than the individual **215**. Consequently, the auxiliary computer **110** wirelessly transmits an alert signal through the network **250** to a personal device **221** of the individual **220** rather than the personal device **216** of the individual **215**. This action may also be carried out by transmitting a text message, and email message, and/or a voice message to individuals **215** and/or **220** that are known to be within the building **150** or are usually within the building **150**. The presence of the individual **215** and/or the individual **220** in the building **150** and/or within a geofence around the building **150** can be based on detect-

ing an operating status of the personal device **215** and/or the personal device **221**. Upon receiving the signal, the individual **220** may go to the garage and close the garage door **130**. In one case, the individual **220** may send a message (or other form of communication) to the auxiliary computer **110** after the individual **220** has closed the garage door **130**. The auxiliary computer **110** may display a message upon the infotainment system **112** of the vehicle **105** to inform the driver **111** that the garage door **130** has been closed.

In one embodiment, the priority list may be dynamic priority list that is updated dynamically on a periodic or as-needed basis. For example, the priority list may be updated dynamically based on who, and how many, individuals are present in the building **150** at a particular time. For example, the priority list may be updated dynamically in the morning when the individual **215** has left the building **150** to go to work so as to omit the individual **215** from the priority list who would be unable to close the garage door **130** upon receiving an alert message. If more than one individual is present in the building **150** when the individual **215** has left for work, the priority list may be updated to reflect a priority status among the various individuals.

The network **250** may include any one, or a combination of networks, such as a local area network (LAN), a wide area network (WAN), a telephone network, a cellular network, a cable network, a wireless network, and/or private/public networks such as the Internet. For example, the network **250** may support communication technologies such as Wi-Fi, Wi-Fi direct, Ultra-Wideband (UBW), machine-to-machine communication, and/or man-to-machine communication. At least one portion of the network **250** includes a wireless communication link that allows the auxiliary computer **110** to communicate with the device **260**, the personal device **216** of the individual **215**, and/or the personal device **221** of the individual **220**.

FIG. 3 illustrates an example geofence **305** that may be used when operating the garage door status detection system **100** in accordance with the disclosure. The geofence **305** in this example implementation is shaped as a circle. However, in other implementations, the geofence **305** can have various other shapes such as, for example, an oval shape, a rectangular shape, a polygonal shape, or an irregular shape. The dimensions of the geofence **305** may be defined by various entities on the basis of various parameters. For example, the dimensions of the geofence **305** may be defined by the driver **111** of the vehicle **105**, or an individual residing in the building **150**, and may be based on a structural part of the building **150** (a corner, for example) or a drivable surface leading up to the building (the driveway **145**, for example).

In an example implementation, the radius of the geofence **305** may be defined on the basis of a length **310** of the driveway **145**. In another example implementation, the radius of the geofence **305** may be defined by an operating range of a garage door opener in the vehicle **105**. In yet another example implementation, the radius of the geofence **305** may be defined by an operating range of a sensor in the vehicle. The sensor can be any sensor in the vehicle **105** that is used to detect the status of the garage door **130** (open, closed, partially open, etc.). The vehicle **105** can include one or more sensors such as for example, the ultrasonic sensor **135** that can measure a separation distance **315** between the vehicle **105** and the garage door **130** to detect whether the vehicle **105** is inside the geofence **305**. Elements of the garage door status detection system **100** (such as the auxiliary computer **110**) refrain from carrying out any action upon the garage door **130** as long as the vehicle **105** is located inside the geofence **305**. Consequently, no action is

taken with respect to the garage door **130** when the vehicle **105** is parked on the driveway **145**.

The ultrasonic sensor **135** determines that the separation distance **315** between the vehicle **105** and the garage door **130** exceeds the radius of the geofence **305** when the vehicle **105** moves out of the driveway **145** and on to the road **140**. At this time, the ultrasonic sensor **135** sends a signal to the auxiliary computer **110** to inform the garage door status detection system **100** of the event. The auxiliary computer **110** may automatically analyze an image or a video clip captured by the image capture system **125** as the vehicle **105** was moving on the driveway **145** so as to identify the status of the garage door **130**. If the garage door **130** is open (or partially closed) the auxiliary computer **110** may automatically take action to initiate closure of the garage door **130** in various ways such as described above.

In some implementations, the auxiliary computer **110** may initiate such actions after a time delay. The time delay may be set by various entities such as, for example, the driver **111** of the vehicle **105** and/or a manufacturer of the vehicle **105**. The time delay may be defined on the basis of various factors, such as, for example, to allow the vehicle **105** to be moved out of the garage temporarily for a brief period of time or to provide additional time to allow a resident of the building **150**, such as, for example, a spouse, to pull out another vehicle after the driver **111** has moved the vehicle **105** out of the garage. When allowing more time for the spouse to pull out the other vehicle, the vehicle **105** may be either located inside the geofence **305** or may have moved outside the geofence **305**. If the vehicle **105** has moved outside the geofence **305**, the garage door status detection system **100** does not attempt to close the garage door **130** until the time delay has expired.

FIG. **4** illustrates an example geofence **405** that may be used when operating the garage door status detection system **100** in accordance with the disclosure. The geofence **405** in this example implementation is T-shaped and surrounds the driveway **145** as well as a section of the road **140**. It must be understood that the T-shape indicated with sharp corners and lines is merely an illustrative example, and the actual shape of the geofence **405** may have a non-linear perimeter that encompasses the driveway **145** and the section of the road **140**.

Elements of the garage door status detection system **100** (such as the auxiliary computer **110**) refrain from carrying out any action upon the garage door **130** as long as the vehicle **105** is located inside the geofence **405**. Consequently, no action is taken with respect to the garage door **130** when the vehicle **105** is parked on the driveway **145** or near the curb on the road **140** abutting the driveway **145**. The dashed line outlines of the vehicle **105** indicate various locations where the vehicle **105** can be parked with no action being taken by the garage door status detection system **100**.

One or more of various sensors or image capture systems in the vehicle **105** may be used to detect a movement of the vehicle **105** outside the geofence **405**. The auxiliary computer **110** may automatically analyze an image or a video clip captured by the image capture system **125** when the vehicle **105** began moving out of the geofence **405** so as to identify the status of the garage door **130**. If the garage door **130** is open (or partially closed) the auxiliary computer **110** may automatically take action to initiate closure of the garage door **130** in various ways such as described above. In some implementations, the auxiliary computer **110** may initiate such actions only after a time delay in the manner described above.

In some cases, the garage door status detection system **100** may verify and/or store, a status of the garage door **130** periodically when the vehicle **105** is located inside the geofence **405**. Being aware of the status of the garage door **130** allows the garage door status detection system **100** to take action upon detecting an unusual condition.

FIG. **5** shows some example components that can be included in the personal device **113** and the auxiliary computer **110** of the garage door status detection system **100** in accordance with the disclosure. The auxiliary computer **110** may include a processor **505**, a communication system **535**, a garage door status detection system hardware **545**, and a memory **510**. The communication system **535** can include a wireless transceiver that allows the auxiliary computer **110** to communicate with various devices such as the personal device **113** (for example, to display garage door status to the driver **111**) and/or the server computer **270**.

The wireless transceiver may use one or more of various wireless technologies such as Bluetooth®, Ultra-Wideband (UWB), Wi-Fi, ZigBee®, Li-Fi (light-based communication), audible communication, ultrasonic communication, or near-field-communications (NFC), for carrying out wireless communications with devices such as the personal device **113**. The wireless transceiver may use any of various communication formats such as, for example, a vehicle-to-everything (V2X) communication format, an Internet communications format, or a cellular communications format for communicating with the server computer **270**, or with devices such as the personal device **216** of the individual **215** and the personal device **221** of the individual **220**.

The communication system **535** may also include circuitry for receiving information (signals, images etc.) from various devices in the vehicle **105**, such as, for example, the image capture system **120**, the image capture system **125**, and the ultrasonic sensor **135**.

The garage door status detection system hardware **545** can include devices that cooperate with various sensors and detectors such as the image capture system **120**, the image capture system **125**, the ultrasonic sensor **135**, the radar sensor **160**, and/or the LIDAR device **165**. In some implementations, the garage door status detection system hardware **545** can be omitted from the auxiliary computer **110** and incorporated into the vehicle systems controller **115** instead.

The memory **510**, which is one example of a non-transitory computer-readable medium, may be used to store an operating system (OS) **530**, a database **526**, and code modules such as a communication system module **515**, a garage door status detection module **520**, and an image processing module **525**. The code modules are provided in the form of computer-executable instructions that can be executed by the processor **505** for performing various operations in accordance with the disclosure.

The communication system module **515** may include computer-executable instructions for allowing the garage door status detection module **520** to communicate with various elements such as the personal device **113** of the driver **111**, the personal device **216** of the individual **215**, the personal device **221** of the individual **220**, the server computer **270**, the image capture system **120**, the image capture system **125**, and the ultrasonic sensor **135**.

The database **526** may be used to store reference images, such as a front view of the building **150**, a view of the garage door **130** when in a closed condition, a view of the garage door **130** when in an open condition, a view of the garage door **130** when in a partially-open condition, and a view of

the garage door **130** during various time so of the day (morning, evening, night etc.).

The garage door status detection module **520** can enable the auxiliary computer **110** to carry out various actions described herein with respect to the garage door **130**. Some example actions may include cooperating with the communication system **535** and/or the garage door status detection system hardware **545** for obtaining and analyzing images or video clips of the garage door **130**, defining a geofence (such as the geofence **305** and the geofence **405**), and determining that the vehicle **105** has moved outside the geofence.

In some embodiments, the garage door status detection module **520** may utilize the image processing module **525** to process images that are provided to the auxiliary computer **110** by an image capture system in the vehicle **105** (such as the image capture system **120** or the image capture system **125**). The processing may be directed at determining whether the garage door **130** is in an open condition, closed condition, or a partially-open condition. Various image processing techniques may be used such as, for example, an image processing algorithm modeled on a neural network that is trained to analyze images of the garage door **130** at various times, in various conditions, and in various configurations.

In some embodiments, reference images may be used by the image processing module **525** for detecting a status of the garage door **130**. For example, a first reference image may provide an indication of the garage door **130** in an open condition, a second reference image may provide an indication of the garage door **130** in a closed condition, and a third reference image may provide an indication of the garage door **130** in a partially-open condition.

In some embodiments, reference parameters such as distance parameters may be used by the image processing module **525** for detecting a status of the garage door **130**. The distance parameters may be generated by using sensors such as, for example, the ultrasonic sensor **135**, the radar sensor **160**, and/or the LIDAR device. A first reference distance parameter may, for example, provide an indication of a distance between the vehicle **105** and the garage door **130** when the vehicle **105** is at a known location (end of the driveway, for example). A second reference distance parameter may, for example, provide an indication of a distance between the vehicle **105** and an object such as a mailbox, for example. Thus, for example, the garage door status detection module **520** may conclude that the garage door **130** is open when a distance measured by a sensor when the vehicle **105** is located at the end of the driveway exceeds the first reference distance parameter.

In another embodiment, the garage door status detection module **520** may process images to detect that the garage door **130** is open under abnormal circumstances. For example, the garage door **130** may be open late at night when the vehicle **105** is parked inside the garage. A message may be sent out to one or more individuals in the form of an alert or a recommendation to close the garage door **130**.

The personal device **113** may include a processor **555** and a memory **560**. The memory **560**, which is another example of a non-transitory computer-readable medium, may be used to store an operating system (OS) **575** and code modules such as a communication system module **565** and a garage door status detection module **570**. The code modules are provided in the form of computer-executable instructions that can be executed by the processor **555** for performing various operations in accordance with the disclosure.

The communication system module **565** may allow the personal device **113** to communicate with the communica-

tion system **535** of the auxiliary computer **110**. The garage door status detection module **570** may include computer-executable instructions for enabling the personal device **113** to interact with the auxiliary computer **110** for various purposes such as to receive alerts when the auxiliary computer **110** detects the garage door **130** in an open condition. In one example implementation, the garage door status detection module **520** may be provided in the form of a software application that is loaded into the personal device **113**. The driver **111** may do so, for example, by downloading the application from a website.

In the above disclosure, reference has been made to the accompanying drawings, which form a part hereof, which illustrate specific implementations in which the present disclosure may be practiced. It is understood that other implementations may be utilized, and structural changes may be made without departing from the scope of the present disclosure. References in the specification to “one embodiment,” “an embodiment,” or “an example embodiment,” etc., indicate that the embodiment described may include a particular feature, structure, or characteristic, but every embodiment may not necessarily include the particular feature, structure, or characteristic. Moreover, such phrases are not necessarily referring to the same embodiment. Further, when a particular feature, structure, or characteristic is described in connection with an embodiment, one skilled in the art will recognize such feature, structure, or characteristic in connection with other embodiments whether or not explicitly described.

Implementations of the systems, apparatuses, devices, and methods disclosed herein may comprise or utilize one or more devices that include hardware, such as, for example, one or more processors and system memory, as discussed herein. An implementation of the devices, systems, and methods disclosed herein may communicate over a computer network. A “network” is defined as one or more data links that enable the transport of electronic data between computer systems and/or modules and/or other electronic devices. When information is transferred or provided over a network or another communications connection (either hardwired, wireless, or any combination of hardwired or wireless) to a computer, the computer properly views the connection as a transmission medium. Transmission media can include a network and/or data links, which can be used to carry desired program code means in the form of computer-executable instructions or data structures and which can be accessed by a general purpose or special purpose computer. Combinations of the above should also be included within the scope of non-transitory computer-readable media.

Computer-executable instructions comprise, for example, instructions and data which, when executed at a processor, cause the processor to perform a certain function or group of functions. The computer-executable instructions may be, for example, binaries, intermediate format instructions such as assembly language, or even source code. Although the subject matter has been described in language specific to structural features and/or methodological acts, it is to be understood that the subject matter defined in the appended claims is not necessarily limited to the described features or acts described above. Rather, the described features and acts are disclosed as example forms of implementing the claims.

A memory device such as the memory **510** and the memory **560**, can include any one memory element or a combination of volatile memory elements (e.g., random access memory (RAM, such as DRAM, SRAM, SDRAM, etc.)) and non-volatile memory elements (e.g., ROM, hard

drive, tape, CDROM, etc.). Moreover, the memory device may incorporate electronic, magnetic, optical, and/or other types of storage media. In the context of this document, a “non-transitory computer-readable medium” can be, for example but not limited to, an electronic, magnetic, optical, electromagnetic, infrared, or semiconductor system, apparatus, or device. More specific examples (a non-exhaustive list) of the computer-readable medium would include the following: a portable computer diskette (magnetic), a random-access memory (RAM) (electronic), a read-only memory (ROM) (electronic), an erasable programmable read-only memory (EPROM, EEPROM, or Flash memory) (electronic), and a portable compact disc read-only memory (CD ROM) (optical). Note that the computer-readable medium could even be paper or another suitable medium upon which the program is printed, since the program can be electronically captured, for instance, via optical scanning of the paper or other medium, then compiled, interpreted or otherwise processed in a suitable manner if necessary, and then stored in a computer memory.

Those skilled in the art will appreciate that the present disclosure may be practiced in network computing environments with many types of computer system configurations, including in-dash vehicle computers, personal computers, desktop computers, laptop computers, message processors, handheld devices, multi-processor systems, microprocessor-based or programmable consumer electronics, network PCs, minicomputers, mainframe computers, mobile telephones, PDAs, tablets, pagers, routers, switches, various storage devices, and the like. The disclosure may also be practiced in distributed system environments where local and remote computer systems, which are linked (either by hardwired data links, wireless data links, or by any combination of hardwired and wireless data links) through a network, both perform tasks. In a distributed system environment, program modules may be located in both the local and remote memory storage devices.

Further, where appropriate, the functions described herein can be performed in one or more of hardware, software, firmware, digital components, or analog components. For example, one or more application specific integrated circuits (ASICs) can be programmed to carry out one or more of the systems and procedures described herein. Certain terms are used throughout the description, and claims refer to particular system components. As one skilled in the art will appreciate, components may be referred to by different names. This document does not intend to distinguish between components that differ in name, but not function.

It should be noted that the sensor embodiments discussed above may comprise computer hardware, software, firmware, or any combination thereof to perform at least a portion of their functions. For example, a sensor may include computer code configured to be executed in one or more processors and may include hardware logic/electrical circuitry controlled by the computer code. These example devices are provided herein for purposes of illustration and are not intended to be limiting. Embodiments of the present disclosure may be implemented in further types of devices, as would be known to persons skilled in the relevant art(s).

At least some embodiments of the present disclosure have been directed to computer program products comprising such logic (e.g., in the form of software) stored on any computer-usable medium. Such software, when executed in one or more data processing devices, causes a device to operate as described herein.

While various embodiments of the present disclosure have been described above, it should be understood that they

have been presented by way of example only, and not limitation. It will be apparent to persons skilled in the relevant art that various changes in form and detail can be made therein without departing from the spirit and scope of the present disclosure. Thus, the breadth and scope of the present disclosure should not be limited by any of the above-described example embodiments but should be defined only in accordance with the following claims and their equivalents. The foregoing description has been presented for the purposes of illustration and description. It is not intended to be exhaustive or to limit the present disclosure to the precise form disclosed. Many modifications and variations are possible in light of the above teaching. Further, it should be noted that any or all of the aforementioned alternate implementations may be used in any combination desired to form additional hybrid implementations of the present disclosure. For example, any of the functionality described with respect to a particular device or component may be performed by another device or component. Further, while specific device characteristics have been described, embodiments of the disclosure may relate to numerous other device characteristics. Further, although embodiments have been described in language specific to structural features and/or methodological acts, it is to be understood that the disclosure is not necessarily limited to the specific features or acts described. Rather, the specific features and acts are disclosed as illustrative forms of implementing the embodiments. Conditional language, such as, among others, “can,” “could,” “might,” or “may,” unless specifically stated otherwise, or otherwise understood within the context as used, is generally intended to convey that certain embodiments could include, while other embodiments may not include, certain features, elements, and/or steps. Thus, such conditional language is not generally intended to imply that features, elements, and/or steps are in any way required for one or more embodiments.

That which is claimed is:

1. A method comprising:

determining a location of a vehicle relative to a geofence; determining a location of one or more devices associated with one or more individuals relative to the geofence; detecting, by a garage door status detection system in the vehicle and based on the location of the vehicle being outside the geofence, one of a closed condition, an open condition, or a partially-open condition of a garage door of a building;

transmitting, by a communication device in the vehicle and based on the detecting, a door-position status of the garage door to at least one of the one or more devices; identifying which device or devices of the one of more devices will receive the door-position status using on a priority list; and transmitting, to the identified device or devices, the door-position status in a text message, an email message, and/or a voice message.

2. The method of claim **1**, wherein the garage door status detection system comprises an image capture system, and wherein the method further comprises:

determining the door-position status of the garage door by analyzing an image captured by the image capture system.

3. The method of claim **2**, wherein transmitting the door-position status comprises transmitting a text message, an email message, and/or a voice message to the at least one of the one or more devices.

4. The method of claim **1**, wherein the identified device or devices are within the geofence.

13

5. The method of claim 1, wherein only a first device of the one or more devices receives the door-position status and the method further comprises examining the priority list to determine a priority of the first device in the priority list, wherein the priority list uses the location of one or more devices to determine the priority.

6. The method of claim 1, wherein the garage door status detection system comprises an ultrasonic sensor, and wherein determining the door-position status of the garage door comprises transmitting an ultrasonic signal from the ultrasonic sensor towards the garage door.

7. A method comprising:

determining a location of a vehicle relative to a geofence; determining a location of one or more devices associated

with one or more individuals relative to the geofence; receiving, by a garage door status detection system in the vehicle and based on the location of the vehicle being outside the geofence, an inquiry for a door-position status of a garage door of a building;

operating a detection apparatus in the vehicle to detect the door-position status of the garage door or retrieving stored information about the door-position status of the garage door;

identifying which device or devices of the one or more devices will receive the door-position status using on a priority list; and

transmitting, to the identified device or devices, the door-position status in a text message, an email message, and/or a voice message.

8. The method of claim 7, wherein the door-position status comprises one of a closed condition, an open condition, or a partially-open condition and a signal is sent to close the garage door when the door-position status is in an open condition or a partially-open condition and all of the one or more devices are outside the geofence.

9. The method of claim 7, wherein the garage door status detection system comprises an image capture system and wherein operating the detection apparatus in the vehicle to detect the door-position status of the garage door comprises:

operating the image capture system to capture one of a video clip or an image of the garage door when the vehicle is exiting a garage through the garage door; and storing the one of the video clip or the image in a storage element.

10. The method of claim 9, wherein operating the image capture system to capture the one of the video clip or the image of the garage door is automatically initiated by the garage door status detection system when the vehicle is one of exiting the garage or moving out of a driveway of the building.

11. The method of claim 9, wherein the storage element is one of located in the vehicle or is a part of cloud-storage.

14

12. The method of claim 9, wherein retrieving stored information about the door-position status of the garage door comprises retrieving the one of the video clip or the image when the vehicle is outside of a boundary.

13. The method of claim 12, further comprising:

displaying the one of the video clip or the image upon a display device in the vehicle.

14. A non-transitory computer-readable memory medium configured to store instructions thereon that when loaded by at least one processor cause the at least one processor to:

determine a location of a vehicle relative to a geofence; determine a location of one or more devices associated with one or more individuals relative to the geofence; detect, based on the location of the vehicle, one of a closed condition, an open condition, or a partially-open condition of a garage door of a building;

transmit a door-position status of the garage door to at least one of the one or more devices wherein only a first device of the one or more devices receives the door-position status; and

examining a priority list to determine a priority of the first device in the priority list, wherein the priority list uses the location of one or more devices to determine the priority.

15. The non-transitory computer-readable memory medium of claim 14, wherein the instructions loaded by the at least one processor further cause the at least one processor to determine the door-position status of the garage door by analyzing an image captured by the image capture system.

16. The non-transitory computer-readable memory medium of claim 15, wherein the instructions loaded by the at least one processor further causes the at least one processor to transmit the door-position status in a text message, an email message, and/or a voice message to a driver of the vehicle.

17. The non-transitory computer-readable memory medium of claim 15, wherein the at least one processor is further configured to:

identify a first device of the one or more devices using the priority list as a receiving device; and

transmit, to the first device, the door-position status in a text message, an email message, and/or a voice message.

18. The non-transitory computer-readable memory medium of claim 17, wherein the instructions loaded by the at least one processor further determine a priority of the first device in the priority list.

19. The non-transitory computer-readable memory medium of claim 14, wherein the instructions loaded by the at least one processor determine the door-position status of the garage door by transmitting an ultrasonic signal from a ultrasonic sensor towards the garage door.

* * * * *