

# Technical specifications.

## BMW 7 Series.

### i7 xDrive60.



BMW i7 xDrive60		
<b>Vehicle Category</b>		
Drive type / body style	Battery electric vehicle (BEV) / Sedan	
<b>Body</b>		
No. of doors / seats	4 / 5	
Length/width/height (unladen)	mm	5391 / 1950 / 1544
Wheelbase	mm	3215
Track, front/rear	mm	1714 / 1735
Turning circle	m	13.1
Turning circle with Integral Active Steering	m	12.3
Ground clearance (unladen)	mm	136
Weight, unladen (DIN/EU)	kg	2640 / 2715
Max. load to DIN	kg	610
Max. permissible weight	kg	3250
Max. axle load, front/rear	kg	1550 / 1810
Max. trailer load, braked (12%/unbraked)	kg	2000 / 750
Max. roofload/towbar download	kg	- / 80
Luggage comp. capacity	l	500
Air resistance	c <sub>x</sub> x A	0.24 x 2.60
<b>Power Unit</b>		
Drive concept	Electric all-wheel drive, drive torque sent by one electric motor to the front wheels and one to the rear wheels, as required, in a coordinated process	
Max. system output	kW/hp	400 / 544
Max. system torque	Nm	745
System power-to-weight ratio	kg/kW	6.6
Type of transmission	Automatic transmission, single-stage with fixed ratio	
<b>Electric Motors</b>		
Motor technology	Fifth-generation BMW eDrive technology: electrically excited synchronous motors, power electronics and transmission sharing the same housing, generator function for recuperating energy	
<b>Front Electric Motor</b>		
Peak output to ECE R 85	kW/hp	190 / 258
at	rpm	8000
Continuous output to ECE R 85	kW/hp	70 / 95
Max. torque	Nm	365
at	rpm	0 – 5000
Gear ratio	:1	8.770
<b>Rear Electric Motor</b>		
Peak output to ECE R 85	kW/hp	230 / 313
at	rpm	8000
Continuous output to ECE R 85	kW/at	95 / 129
Max. torque	Nm	380
at	rpm	0 – 6000
Gear ratio	:1	9.400
<b>High-voltage Battery</b>		
Storage technology	Lithium-ion	
Installation	Underfloor	
Voltage	V	376.4
Battery capacity	Ah	280.8
Energy capacity, net	kWh	101.7
Charging time, 10 – 100% charge	< 5.5 hours at 22 kW (32 A / 380 V, three-phase AC, Wallbox)	
Charging time, 10 – 80% charge	34 min. at 195 kW (DC, fast-charging station)	
<b>Charging Unit</b>		
Type	Combined Charging Unit (CCU) with built-in 4 kW voltage transformer for supplying power to the 12V electrical system	
Max. charging rate AC, single-phase	kW	3.7 (EU) / 7.4 (incl. CN, KR) / 11.0 (US, JP)
Max. charging rate AC, three-phase	kW	22.0
Max. charging rate DC	kW	195

<b>BMW i7 xDrive60</b>			
<b>Driving Dynamics and Safety</b>			
Suspension, front		Double-wishbone axle in aluminium construction, adaptive air suspension with automatic self-levelling, electronically controlled dampers	
Suspension, rear		Five-link axle in aluminium construction, adaptive air suspension with automatic self-levelling, electronically controlled dampers	
Brakes, front		Vented disc brakes, with four-piston fixed callipers	
Brakes, rear		Vented disc brakes, with single-piston floating callipers	
Driving stability systems		Standard: DSC incl. ABS, ASC and DTC (Dynamic Traction Control), ARB technology (near-actuator wheel slip limitation), CBC (Cornering Brake Control), DBC (Dynamic Brake Control), Dry Braking function, fading compensation, drive-off assistant, trailer stability control, Performance Control; optional: active roll stabilisation	
Safety equipment		Standard: airbags for driver and front passenger, side airbags for driver and front passenger, head airbags for front and rear seats, three-point inertia-reel seatbelts on all seats with belt stopper, belt tensioner and belt force limiter in the front, crash sensors, tyre pressure indicator	
Steering		Electric Power Steering (EPS) with Servotronic function and variable steering ratio; optional: Integral Active Steering	
Steering ratio, overall		:1	15.6
Tyres, front/rear		245/50 R19 105Y XL	
Rims, front/rear		8.5J x 19 light-alloy	
<b>Performance</b>			
Acceleration	0–100 km/h	s	4.7
Top speed		km/h	240 (electronically limited)
<b>Electric Power Consumption / Range</b>			
Electric power consumption combined (WLTP)		kWh/100 km	19.6 – 18.4
Electric power consumption combined (NEDC)		kWh/100 km	–
Range (WLTP)		km	591 – 625
<b>Environmental Characteristics</b>			
Emission rating		Electric vehicle	

Specifications apply to ACEA markets/data relevant to homologation applies in part only to Germany (weight)  
All figures relating to performance, fuel/electric power consumption and emissions are provisional.

The fuel consumption, CO<sub>2</sub> emissions, electric power consumption and electric range figures are determined according to the European Regulation (EC) 715/2007 in the version applicable. The figures refer to a vehicle with basic configuration in Germany and the range shown considers the different sizes of the selected wheels/tyres and the selected items of optional equipment.

All values were calculated based on the new WLTP test cycle. WLTP values are taken as the basis for determining vehicle-related taxes or other duties based (at least inter alia) on CO<sub>2</sub> emissions as well as eligibility for any applicable vehicle-specific subsidies. Further information on the WLTP and NEDC measurement procedures can also be found at [www.bmw.de/wltp](http://www.bmw.de/wltp).

Further information on official fuel consumption figures and specific CO<sub>2</sub> emission values of new passenger cars is included in the following guideline: 'Leitfaden über den Kraftstoffverbrauch, die CO<sub>2</sub>-Emissionen und den Stromverbrauch neuer Personenkraftwagen' (Guide to the fuel economy, CO<sub>2</sub> emissions and electric power consumption of new passenger cars), which can be obtained free of charge from all dealerships, from Deutsche Automobil Treuhand GmbH (DAT), Hellmuth-Hirth-Str. 1, 73760 Ostfildern-Scharnhausen and at <https://www.dat.de/co2>.

# BMW 7 Series. 735i. (Not available in Europe)

<b>BMW 735i</b>		
<b>Body</b>		
No. of doors / seats		4 / 5
Length/width/height (unladen)	mm	5391 / 1950 / 1544
Wheelbase	mm	3215
Track, front/rear	mm	1713 / 1736
Turning circle	m	12.9
Fuel tank capacity	approx. l	74
Engine oil <sup>1)</sup>	l	<sup>3)</sup>
Weight, unladen, to DIN/EU	kg	2075 / 2150
Max. load to DIN	kg	710
Max. permissible weight	kg	2785
Max. axle load, front/rear	kg	1325 / 1510
Max. trailer load		
braked (12%/unbraked)	kg	- / -
Max. roofload/towbar download	kg	- / -
Luggage comp. capacity	l	540
Air resistance	cx x A	0.26 x 2.59
<b>Power Unit</b>		
Engine technology		BMW TwinPower Turbo technology: turbocharger, High Precision Injection, VALVETRONIC fully variable valve timing, Double-VANOS variable camshaft timing, 48V mild hybrid technology using an electric motor integrated into the transmission
Max. output, overall <sup>2)</sup>	kW/hp	210 / 286
Max. torque, overall <sup>2)</sup>	Nm	425
<b>Petrol Engine</b>		
Config./No. of cyls./valves		In-line / 6 / 4
Effective capacity	cc	2998
Stroke/bore	mm	94.6 / 82.0
Compression ratio	:1	11.0
Fuel		Min. RON 91
Nominal power	kW/hp	200 / 272
at	rpm	5000 – 6500
Nominal torque	Nm	400
at	rpm	1750 – 4500
Output per litre	kW/l	66.7
<b>Electric Motor</b>		
Nominal power	kW/hp	13 / 18
Nominal torque	Nm	200
<b>Electrical System</b>		
12V battery/installation	Ah/-	70 / engine compartment
48V battery/installation	Ah/-	20 / luggage compartment
<b>Driving Dynamics and Safety</b>		
Suspension, front		Double-wishbone axle in aluminium construction, adaptive air suspension with automatic self-levelling, electronically controlled dampers
Suspension, rear		Five-link axle in aluminium construction, adaptive air suspension with automatic self-levelling, electronically controlled dampers
Brakes, front		Vented disc brakes, with four-piston fixed callipers
Brakes, rear		Vented disc brakes, with single-piston floating callipers
Driving stability systems		Standard: DSC incl. ABS, ASC and DTC (Dynamic Traction Control), ARB technology (near-actuator wheel slip limitation), CBC (Cornering Brake Control), DBC (Dynamic Brake Control), Dry Braking function, fading compensation, drive-off assistant, Performance Control; optional: active roll stabilisation
Safety equipment		Standard: airbags for driver and front passenger, side airbags for driver and front passenger, head airbags for front and rear seats, three-point inertia-reel seatbelts on all seats with belt stopper, belt tensioner and belt force limiter in the front, crash sensors, tyre pressure indicator
Steering		Electric Power Steering (EPS) with Servotronic function and variable steering ratio; optional: Integral Active Steering
Steering ratio, overall	:1	15.4
Tyres, front/rear		245/50 R19 105Y XL
Rims, front/rear		8.5J x 19 light-alloy

<b>BMW 735i</b>		
<b>Transmission</b>		
Type of transmission	Eight-speed Steptronic transmission	
<b>Performance</b>		
Power-to-weight ratio (DIN)	kg/kW	9.9
Acceleration 0–100 km/h	s	6.7
Top speed	km/h	250
<b>BMW EfficientDynamics</b>		
BMW EfficientDynamics standard features	48V mild hybrid technology, Brake Energy Regeneration with recuperation display, Auto Start Stop function, Personal and Efficient mode with coasting function, Proactive Driving Assistant, Optimum Shift Indicator, Electric Power Steering, BMW EfficientLightweight, optimised aerodynamic attributes, active air flap control, on-demand operation of ancillary units, map-regulated oil pump, differential with optimised warm-up behaviour, tyres with reduced rolling resistance	
<b>Fuel Consumption ECE</b>		
Combined (WLTP)	l/100	7.9
CO <sub>2</sub> (WLTP)	g/km	182
Combined (NEDC)	l/100	–
CO <sub>2</sub> (NEDC)	g/km	–
Emission rating	Euro 6d	

Specifications apply to ACEA markets/data relevant to homologation applies in part only to Germany (weight)  
All figures relating to performance, fuel/electric power consumption and emissions are provisional.

<sup>1)</sup> Oil change

<sup>2)</sup> Developed by the combination of the combustion engine (stated nominal figure) and the electric motor (up to stated nominal figure)

<sup>3)</sup> Figures not yet available

The fuel consumption, CO<sub>2</sub> emissions, electric power consumption and electric range figures are determined according to the European Regulation (EC) 715/2007 in the version applicable. The figures refer to a vehicle with basic configuration in Germany and the range shown considers the different sizes of the selected wheels/tyres and the selected items of optional equipment.

All values were calculated based on the new WLTP test cycle. WLTP values are taken as the basis for determining vehicle-related taxes or other duties based (at least inter alia) on CO<sub>2</sub> emissions as well as eligibility for any applicable vehicle-specific subsidies. Further information on the WLTP and NEDC measurement procedures can also be found at [www.bmw.de/wltp](http://www.bmw.de/wltp).

Further information on official fuel consumption figures and specific CO<sub>2</sub> emission values of new passenger cars is included in the following guideline: 'Leitfaden über den Kraftstoffverbrauch, die CO<sub>2</sub>-Emissionen und den Stromverbrauch neuer Personenkraftwagen' (Guide to the fuel economy, CO<sub>2</sub> emissions and electric power consumption of new passenger cars), which can be obtained free of charge from all dealerships, from Deutsche Automobil Treuhand GmbH (DAT), Hellmuth-Hirth-Str. 1, 73760 Ostfildern-Scharnhausen and at <https://www.dat.de/co2>.

# BMW 7 Series. 740i. (Not available in Europe)

<b>BMW 740i</b>		
<b>Body</b>		
No. of doors / seats		4 / 5
Length/width/height (unladen)	mm	5391 / 1950 / 1544
Wheelbase	mm	3215
Track, front/rear	mm	1713 / 1736
Turning circle	m	12.9
Fuel tank capacity	approx. l	74
Engine oil <sup>1)</sup>	l	<sup>3)</sup>
Weight, unladen, to DIN/EU	kg	2090 / 2165
Max. load to DIN	kg	695
Max. permissible weight	kg	2785
Max. axle load, front/rear	kg	1340 / 1510
Max. trailer load		
braked (12%/unbraked)	kg	2100 / 750
Max. roofload/towbar download	kg	- / 85
Luggage comp. capacity	l	540
Air resistance	cx x A	0.26 x 2.59
<b>Power Unit</b>		
Engine technology		BMW TwinPower Turbo technology: turbocharger, High Precision Injection, VALVETRONIC fully variable valve timing, Double-VANOS variable camshaft timing, 48V mild hybrid technology using an electric motor integrated into the transmission
Max. output, overall <sup>2)</sup>	kW/hp	280 / 380
Max. torque, overall <sup>2)</sup>	Nm	540
<b>Petrol Engine</b>		
Config./No. of cyls./valves		In-line / 6 / 4
Effective capacity	cc	2998
Stroke/bore	mm	94.6 / 82.0
Compression ratio	:1	11.0
Fuel		Min. RON 91
Nominal power	kW/hp	280 / 380
at	rpm	5200 – 6250
Nominal torque	Nm	520
at	rpm	1850 – 5000
Output per litre	kW/l	93.4
<b>Electric Motor</b>		
Nominal power	kW/hp	13 / 18
Nominal torque	Nm	200
<b>Electrical System</b>		
12V battery/installation	Ah/-	70 / engine compartment
48V battery/installation	Ah/-	20 / luggage compartment
<b>Driving Dynamics and Safety</b>		
Suspension, front		Double-wishbone axle in aluminium construction, adaptive air suspension with automatic self-levelling, electronically controlled dampers
Suspension, rear		Five-link axle in aluminium construction, adaptive air suspension with automatic self-levelling, electronically controlled dampers
Brakes, front		Vented disc brakes, with four-piston fixed callipers
Brakes, rear		Vented disc brakes, with single-piston floating callipers
Driving stability systems		Standard: DSC incl. ABS, ASC and DTC (Dynamic Traction Control), ARB technology (near-actuator wheel slip limitation), CBC (Cornering Brake Control), DBC (Dynamic Brake Control), Dry Braking function, fading compensation, drive-off assistant, trailer stability control, Performance Control; optional: active roll stabilisation
Safety equipment		Standard: airbags for driver and front passenger, side airbags for driver and front passenger, head airbags for front and rear seats, three-point inertia-reel seatbelts on all seats with belt stopper, belt tensioner and belt force limiter in the front, crash sensors, tyre pressure indicator
Steering		Electric Power Steering (EPS) with Servotronic function and variable steering ratio; optional: Integral Active Steering
Steering ratio, overall	:1	15.4
Tyres, front/rear		245/50 R19 105Y XL
Rims, front/rear		8.5J x 19 light-alloy

<b>BMW 740i</b>		
<b>Transmission</b>		
Type of transmission	Eight-speed Steptronic transmission	
<b>Performance</b>		
Power-to-weight ratio (DIN)	kg/kW	7.5
Acceleration 0-100 km/h	s	5.4
Top speed	km/h	250
<b>BMW EfficientDynamics</b>		
BMW EfficientDynamics standard features	48V mild hybrid technology, Brake Energy Regeneration with recuperation display, Auto Start Stop function, Personal and Efficient mode with coasting function, Proactive Driving Assistant, Optimum Shift Indicator, Electric Power Steering, BMW EfficientLightweight, optimised aerodynamic attributes, active air flap control, on-demand operation of ancillary units, map-regulated oil pump, differential with optimised warm-up behaviour, tyres with reduced rolling resistance	
<b>Fuel Consumption ECE</b>		
Combined (WLTP)	l/100	8.0 – 7.0
CO <sub>2</sub> (WLTP)	g/km	183 – 159
Combined (NEDC)	l/100	-
CO <sub>2</sub> (NEDC)	g/km	-
Emission rating	Euro 6d	

Specifications apply to ACEA markets/data relevant to homologation applies in part only to Germany (weight)  
All figures relating to performance, fuel/electric power consumption and emissions are provisional.

<sup>1)</sup> Oil change

<sup>2)</sup> Developed by the combination of the combustion engine (stated nominal figure) and the electric motor (up to stated nominal figure)

<sup>3)</sup> Figures not yet available

The fuel consumption, CO<sub>2</sub> emissions, electric power consumption and electric range figures are determined according to the European Regulation (EC) 715/2007 in the version applicable. The figures refer to a vehicle with basic configuration in Germany and the range shown considers the different sizes of the selected wheels/tyres and the selected items of optional equipment.

All values were calculated based on the new WLTP test cycle. WLTP values are taken as the basis for determining vehicle-related taxes or other duties based (at least inter alia) on CO<sub>2</sub> emissions as well as eligibility for any applicable vehicle-specific subsidies. Further information on the WLTP and NEDC measurement procedures can also be found at [www.bmw.de/wltp](http://www.bmw.de/wltp).

Further information on official fuel consumption figures and specific CO<sub>2</sub> emission values of new passenger cars is included in the following guideline: 'Leitfaden über den Kraftstoffverbrauch, die CO<sub>2</sub>-Emissionen und den Stromverbrauch neuer Personenkraftwagen' (Guide to the fuel economy, CO<sub>2</sub> emissions and electric power consumption of new passenger cars), which can be obtained free of charge from all dealerships, from Deutsche Automobil Treuhand GmbH (DAT), Hellmuth-Hirth-Str. 1, 73760 Ostfildern-Scharnhausen and at <https://www.dat.de/co2>.

# BMW 7 Series. 760i xDrive. (Not available in Europe)

<b>BMW 760i xDrive</b>		
<b>Body</b>		
No. of doors / seats		4 / 5
Length/width/height (unladen)	mm	5391 / 1950 / 1544
Wheelbase	mm	3215
Track, front/rear	mm	1714 / 1736
Turning circle	m	12.9
Fuel tank capacity	approx. l	74
Engine oil <sup>1)</sup>	l	<sup>3)</sup>
Weight, unladen, to DIN/EU	kg	2270 / 2345
Max. load to DIN	kg	710
Max. permissible weight	kg	2980
Max. axle load, front/rear	kg	1470 / 1565
Max. trailer load braked (12%/unbraked)	kg	- / -
Max. roofload/towbar download	kg	- / -
Luggage comp. capacity	l	540
Air resistance	cx x A	0.26 x 2.59
<b>Power Unit</b>		
Engine technology		TwinPower Turbo technology with cross-bank exhaust manifold; two twin-scroll turbochargers, High Precision Injection, VALVETRONIC fully variable valve timing, Double-VANOS variable camshaft timing, 48V mild hybrid technology using an electric motor integrated into the transmission
Max. output, overall <sup>2)</sup>	kW/hp	400 / 544
Max. torque, overall <sup>2)</sup>	Nm	750
<b>Petrol Engine</b>		
Config./No. of cyls./valves		V / 8 / 4
Effective capacity	cc	4395
Stroke/bore	mm	88.3 / 89.0
Compression ratio	:1	11.0
Fuel		Min. RON 91
Nominal power	kW/hp	400 / 544
at	rpm	5500
Nominal torque	Nm	750
at	rpm	1800 – 5000
Output per litre	kW/l	91.0
<b>Electric Motor</b>		
Nominal power	kW/hp	13 / 18
Nominal torque	Nm	200
<b>Electrical System</b>		
12V battery/installation	Ah/-	70 / engine compartment
48V battery/installation	Ah/-	20 / luggage compartment
<b>Driving Dynamics and Safety</b>		
Suspension, front		Double-wishbone axle in aluminium construction, adaptive air suspension with automatic self-levelling, electronically controlled dampers
Suspension, rear		Five-link axle in aluminium construction, adaptive air suspension with automatic self-levelling, electronically controlled dampers
Brakes, front		Vented disc brakes, with four-piston fixed callipers
Brakes, rear		Vented disc brakes, with single-piston floating callipers
Driving stability systems		Standard: DSC incl. ABS, ASC and DTC (Dynamic Traction Control), ARB technology (near-actuator wheel slip limitation), CBC (Cornering Brake Control), DBC (Dynamic Brake Control), Dry Braking function, fading compensation, drive-off assistant, DSC networked with xDrive all-wheel-drive system, Performance Control; optional: active roll stabilisation
Safety equipment		Standard: airbags for driver and front passenger, side airbags for driver and front passenger, head airbags for front and rear seats, three-point inertia-reel seatbelts on all seats with belt stopper, belt tensioner and belt force limiter in the front, crash sensors, tyre pressure indicator
Steering		Electric Power Steering (EPS) with Servotronic function and variable steering ratio; optional: Integral Active Steering
Steering ratio, overall	:1	15.6
Tyres, front/rear		255/45 R20 105Y XL / 285/40 R20 108Y XL
Rims, front/rear		9J x 20 light-alloy / 10.5J x 20 light-alloy

<b>BMW 760i xDrive</b>			
<b>Transmission</b>			
Type of transmission	Eight-speed Steptronic transmission		
<b>Performance</b>			
Power-to-weight ratio (DIN)	kg/kW	5.7	
Acceleration 0-100 km/h	s	4.2	
Top speed	km/h	250	
<b>BMW EfficientDynamics</b>			
BMW EfficientDynamics standard features	48V mild hybrid technology, Brake Energy Regeneration with recuperation display, Auto Start Stop function, Personal and Efficient mode with coasting function, Proactive Driving Assistant, Optimum Shift Indicator, Electric Power Steering, BMW EfficientLightweight, optimised aerodynamic attributes, active air flap control, on-demand operation of ancillary units, map-regulated oil pump, efficiency-optimised all-wheel drive, differential with optimised warm-up behaviour, tyres with reduced rolling resistance		
<b>Fuel Consumption ECE</b>			
Combined (WLTP)	l/100	11.2	
CO <sub>2</sub> (WLTP)	g/km	255	
Combined (NEDC)	l/100	-	
CO <sub>2</sub> (NEDC)	g/km	-	
Emission rating	Euro 6d		

Specifications apply to ACEA markets/data relevant to homologation applies in part only to Germany (weight)  
All figures relating to performance, fuel/electric power consumption and emissions are provisional.

<sup>1)</sup> Oil change

<sup>2)</sup> Developed by the combination of the combustion engine (stated nominal figure) and the electric motor (up to stated nominal figure)

<sup>3)</sup> Figures not yet available

The fuel consumption, CO<sub>2</sub> emissions, electric power consumption and electric range figures are determined according to the European Regulation (EC) 715/2007 in the version applicable. The figures refer to a vehicle with basic configuration in Germany and the range shown considers the different sizes of the selected wheels/tyres and the selected items of optional equipment.

All values were calculated based on the new WLTP test cycle. WLTP values are taken as the basis for determining vehicle-related taxes or other duties based (at least inter alia) on CO<sub>2</sub> emissions as well as eligibility for any applicable vehicle-specific subsidies. Further information on the WLTP and NEDC measurement procedures can also be found at [www.bmw.de/wltp](http://www.bmw.de/wltp).

Further information on official fuel consumption figures and specific CO<sub>2</sub> emission values of new passenger cars is included in the following guideline: 'Leitfaden über den Kraftstoffverbrauch, die CO<sub>2</sub>-Emissionen und den Stromverbrauch neuer Personenkraftwagen' (Guide to the fuel economy, CO<sub>2</sub> emissions and electric power consumption of new passenger cars), which can be obtained free of charge from all dealerships, from Deutsche Automobil Treuhand GmbH (DAT), Hellmuth-Hirth-Str. 1, 73760 Ostfildern-Scharnhausen and at <https://www.dat.de/co2>.



# Exterior and interior dimensions. BMW 7 Series. i7 xDrive60.

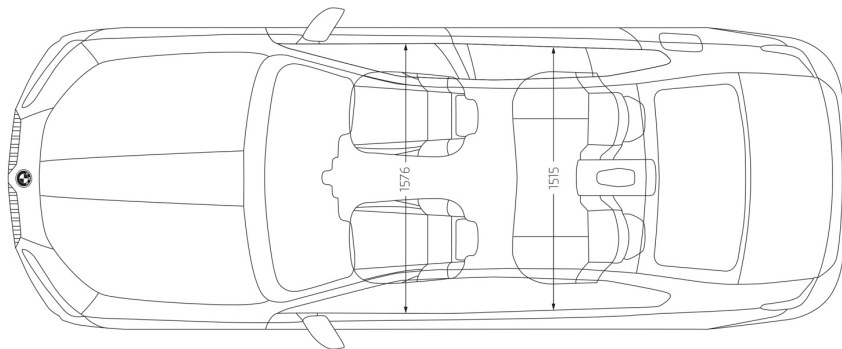
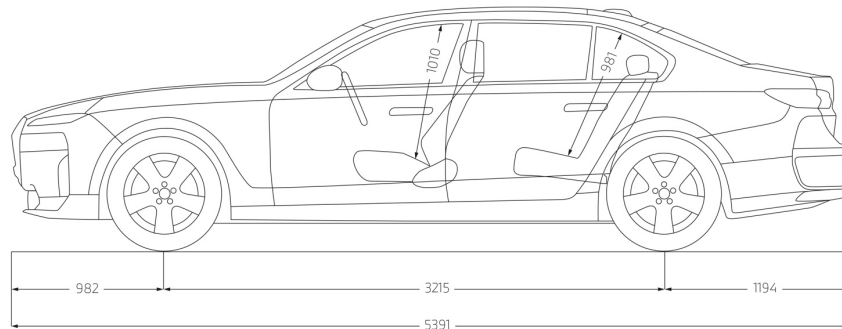
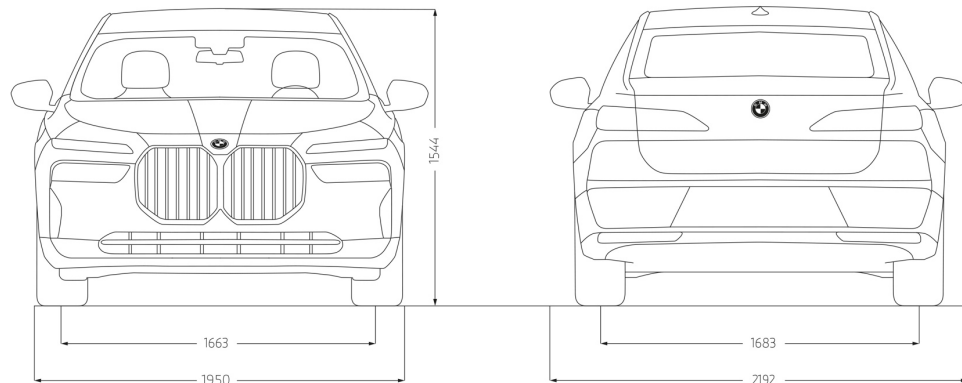

The dimensions of the technical drawing are in millimetres and may vary depending on the model and optional equipment specified.